

TA-116AN97A-A1

Industrial Touch Panel Computer with Intel® N97 CPU/ +12~36 DC input / 11.6" 1366x768 / Fanless / Front IP65



Features

- 11.6" Touch Panel PC system
- Intel® Processor N97
- Single Channel DDR5, 1 x SO-DIMM
- Front bezel meets IP65 rating
- Support VESA mount 75 x 75mm

Graphics support	Integrated Graphics Processor - Intel® UHD Graphics: 2 x HDMI 2.0 port, supporting a maximum resolution of 4096x2160 @60Hz (2 independent display outputs)
Audio	Realtek® ALC897
Expansion slots	1 x 2280 M.2 M-Key (PCIe x2) 1 x 2230 M.2 E-Key 1 x Full-size mini PCIe with SIM slot
TPM	Onboard TPM 2.0 security chip INFINEON SLB9670VQ2.0
Rear I/O	2 x USB 3.2 Gen 2x1 2 x USB 2.0 2 x RJ45 LAN Ports 2 x HDMI 1 x Headphone Jack 1 x Power button with LED 1 x DC input with DC Jack
Power input	+12V~36VDC
Operation Temperature	Operating temperature: 0°C to 40°C Operating humidity: 0-90% (non-condensing) Non-operating temperature: -40°C to 85°C Non-operating humidity: 0%-95% (non-condensing)
IP Protection	Front bezel meets IP-65
Mounting	Wall, Stand with VESA 75 x 75

Specifications

Display	Panel Size	11.6"
	Resolution	1366x768
	Viewing Angle	Horizontal : 170 / Vertical : 170
	Brightness	220 Cd/M²
	Color Support	262K
	Backlight MTBF	15,000 hrs
	Contrast Ratio	800
Touch screen	Touch Type	Projected Capacitive (PCAP)
	Surface Hardness	6H
	Transparency	85%
Dimension	System Size: 290.9W x 194.8D x 52.4H (mm)	
Weight	1.7 Kg	
CPU	Intel Processor N97 Intel 7, 4 cores, up to 3.60 GHz	
Memory	1 x DDR5 SO-DIMM socket, Max. Capacity 16 GB Support Single Channel DDR5 4800 MHz memory module	
Ethernet	2 x 2.5GbE LAN Ports (Intel® I225V)	

Dimension

Unit: mm

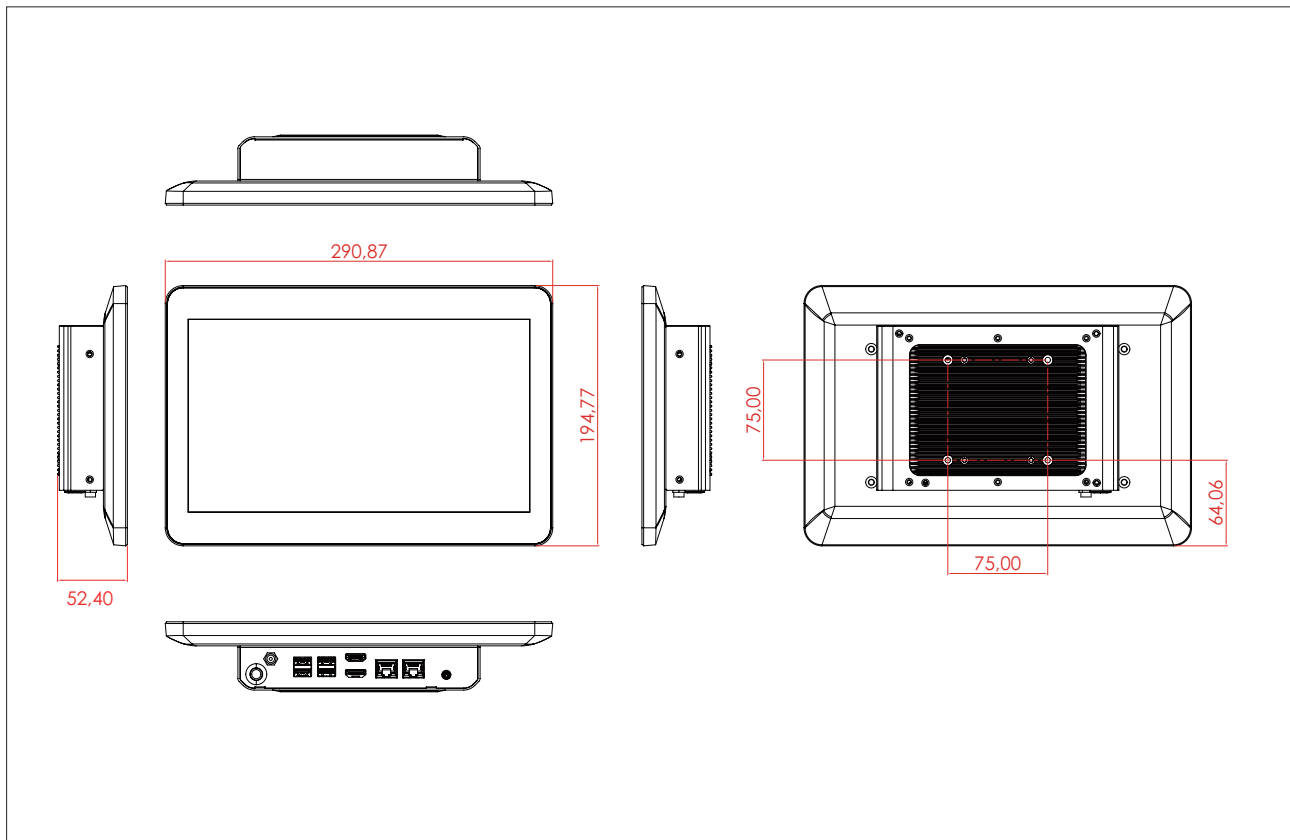

Packing Content

- Carton size: 308 x 294 x 164 (mm)
- Packing Capacity: 1pc
- Including:
 - Power cord : Optional (by region)
 - PSU ADP 19V 65W 100-240VAC x 1 (P/N: 25EP1-100651-A3S)
 - Screws For VESA mounting M4x6L x 4

Order Information

- System: 250L5-111100-M0R (8GB DDR5 RAM, 128GB M.2 SSD)