

# iTXL-1115G4EA (MTGU3AT-SI)

Thin Mini-ITX Embedded Motherboard with Intel® Core™ i3-1115G4E Processor, Dual Channel DDR4 memory, 4 x COM, 1 x SATA 6Gb/s, 10 x USB

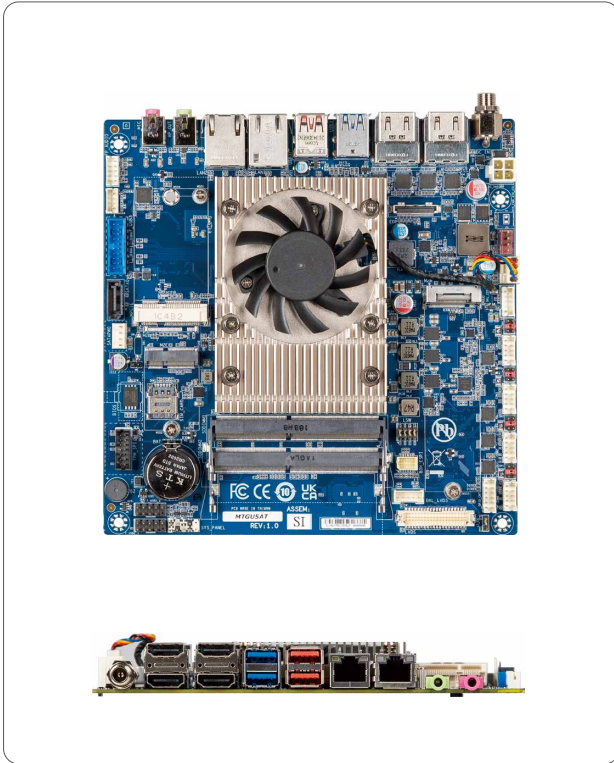

## Specifications

Form Factor	Thin Mini-ITX 170W x 170D (mm)
CPU	Intel® Core™ i3-1115G4E Processor 10nm SuperFin, 2 cores, 4 threads, up to 3.90 GHz TDP 28W 6 MB Smart Cache
Socket	1 x FCBGA1449
Memory	2 x DDR4 SO-DIMM sockets, Max. Capacity 64 GB Support Dual Channel DDR4 3200 MHz memory modules
Ethernet	1 x GbE LAN Port (Intel® I219V) 1 x 2.5GbE LAN Port (Intel® I226V)
Video	Integrated Graphics Processor - Intel® Iris® X Graphics: 4 x HDMI 2.0 ports, supporting a maximum resolution of 4096x2160 @60Hz 1 x LVDS port, supporting a maximum resolution of 1920x1200 @60Hz 1 x eDP port, supporting a maximum resolution of 4096x2304 @60Hz  (4 independent display outputs)
Audio	Realtek® ALC269
Storage	1 x SATA 6Gb/s Port
Raid	RAID 0/1
Expansion Slots	1 x 2280 M.2 M-Key (PCIe Gen 4x4, SATA 6Gb/s) 1 x Full-size Mini PCIe with SIM slot 1 x 2230 M.2 E-key

## Features

- Thin Mini-ITX form factor
- Intel® Core™ i3-1115G4E Processor
- Dual Channel DDR4, 2 x SO-DIMMs
- 1 x GbE LAN Port
- 1 x 2.5GbE LAN Port
- 1 x SATA 6Gb/s Port
- 4 x COM Ports (RS-232/422/485 & RI/5V/12V)

Internal I/O	1 x 4-pin ATX main power connector 1 x SATA Power connector 1 x CPU fan header 1 x System fan header 1 x Front panel header 1 x Front panel audio header 4 x USB 2.0 headers 2 x USB 3.2 Gen 1 headers 4 x COM headers (RS-232/422/485 & RI/5V/12V) 1 x 2W Speaker out header 1 x Backlight Control header for eDP 1 x Backlight Control header for LVDS 1 x GPIO (8 bits) & SMBus header 1 x Buzzer 1 x AT/ATX mode select jumper
Rear I/O	2 x Audio Jacks (Line out, Mic in) 4 x HDMI 2 x RJ45 LAN Ports 2 x USB 3.2 Gen 2x1 2 x USB 3.2 Gen 1 1 x DC Jack (+12~24VDC)
TPM	1 x TPM header (SPI)
OS Compatibility	Windows 10/11 (x64)
Operating Properties	Operating temperature: 0°C to 60°C Operating humidity: 0-90% (non-condensing) Non-operating temperature: -40°C to 85°C Non-operating humidity: 0%-95% (non-condensing)
Packing Content	Carton size: 465 x 351 x 217 (mm) Packing Capacity: 10pcs  Single Box size: 221 x 178 x 65 (mm)  Including: Standard IO Shield x 1 (P/N: 12AIO-MTGU3A-00R) Low-Profile IO Shield x 1 (P/N: 12AIO-MTGU00-00R) SATA Power cable x 1 (P/N: 25CRI-300B01-K1R)
Order Information	9MTGU3ATMR-SI (Box Packing)

GIGAIPC reserves the right to modify or change technical data without prior notice.

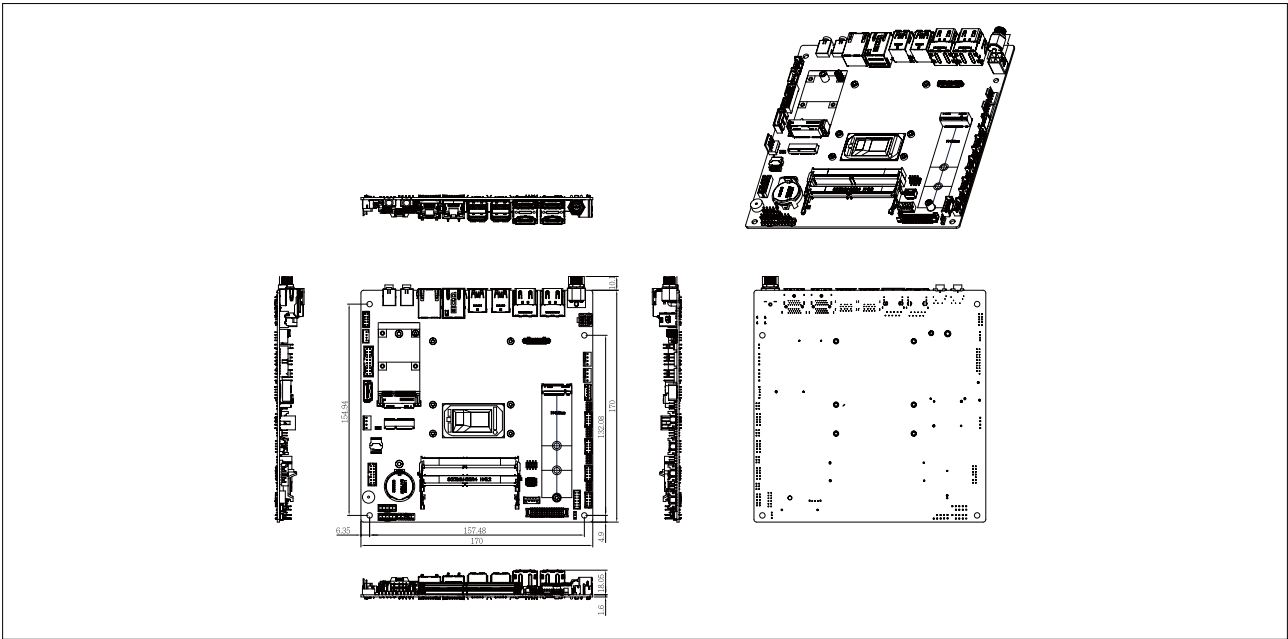

### Block Diagram

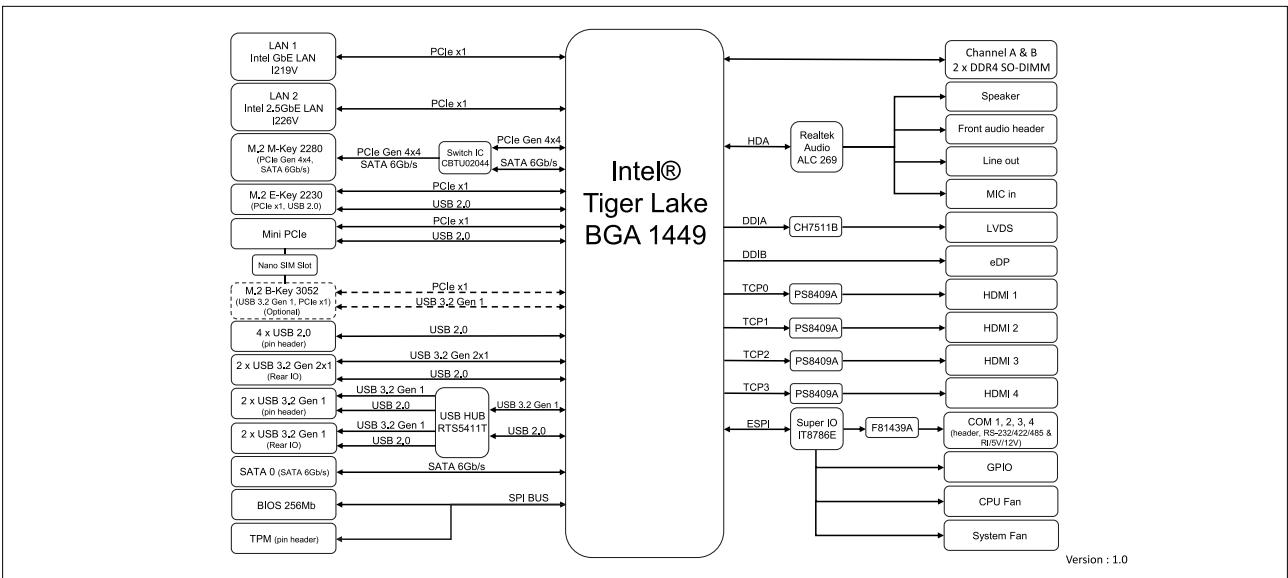

### Optional Kit

Part No.	Description	Quantity
9CTM010NR-00	TPM 2.0 module	1
25CRZ-100600-S9R	TPM Cable	1