



Features

- Anti-bacteria (MRSA) plastic housing
- 15.6"(1366x768), 400nits Diagnostic panel 15.6"(1920 x1080), 500nits FHD panel
- High performance intel 12th /13th generation Core i CPU
- Support Intel Vpro technology by CPU
- Supports Dual Channel DDR5 SODIMM up to 64GB
- IP65 at front side, IPx1 for whole system
- Fanless solution
- Optional 2.5" SATA3 SSD up to 2TB
- Optional Full HD/4K capture card
- Supports PCI-E x4 riser card (option)
- USB/LAN/COM 4KV isolated module (optional order configuration)

Specification

Model	WMP 15P IP0A (STD)	WMP 15P IP0B (ISO)
CPU / Chipset	FCBGA1744 Intel® 13 th Gen. Core i7/i5/i3 & Celeron Processor (15W Max.) / SoC	
Graphic	Intel® Iris Xe Graphics (i7/i5 CPU) / Intel® UHD Graphics (i3 CPU)	
RAM	Two 5200 MHz DDR5 SODIMM Socket Support Dual Channel, non-ECC, up to 64GB	
OS Support	Optional Windows 10 IoT Enterprise LTSC / WIN 11 IoT Enterprise GAC	
Storage	1 x M.2 (M Key 2280) with PCIe4 & SATA3 for SSD, 1 x 2.5" SATA3 SSD/HDD drive bay	
Expansion	1 x PCIe4 (40W max.), 1 x M.2 E Key	
Display Size	15.6" wide TFT-Color LCD (16:9)	
Display	Option 1: 1366 x 768, 16.7M colors, 170(H) / 160(V), 400 nits, CR:500: 1 (Typ) Option 2: 1920 x 1080 (Full HD), 16.7M colors, 178(H) / 178(V), 500 nits, CR:1000: 1 (Typ)	
Touch Screen	Projected Capacitive Multi-Touch Panel / Light Transmission: ≥ 84% / Hardness: 7H pencil, pressure 765g/45° / Life: 50000	
USB	4 x USB3.2 gen II	4 x USB3.2 gen II, 1 x ISO USB2.0
COM	1 x RS232/RS422/RS485 1 x RS232	1 x RS232/RS422/RS485, 1 x RS232 1 x ISO RS232/RS422/RS485, 1 x ISO RS232
LAN	2 x RJ45	2 x RJ45 1 x ISO RJ45
Audio/ Video	1 x Line-out & 1 x Microphone-in (3.5mm phone jack) / 1 x DP1.4a, 1 x HDMI 2.0	
Speakers & Mic.	2 x 2-watt Speakers & Integrated Microphone (at Housing Bottom Side)	
Control Hot Key (R to L)	Battery LED Indicator, Power On/Off, Mute, Volume +/-, Brightness +/-, LCD Backlight On/Off, Clean Me, webcam On/Off, Function Key	
Cooling	Fanless Design with External Heatsink	
Power Input	DC 12-24V input	
Power Adapter	AC input 100~240V / 47 ~ 63 Hz / DC output 12V, 100W (HPU-101)	
Temperature	Operating Temperature: 0~40°C (IEC60068-2-78) / Storage Temperature: -20~60°C	
Humidity	Operating & Storage: 10 ~ 90%, non-condensing	
IP Rating	IP65 at front side, IPx1 for whole system	
Housing	Front: Full flat design / Touch (standard)/ Glass (customized); Rear: Plastic White w/Anti-bacteria (MRSA) Housing	
Dimensions (Net)	430mm (H) x 300mm (V) x 88.4mm (T)	
Weights (Net)	5.0 kg (w/o power adapter/battery pack)	
Mounting	VESA 75x75, 100 x 100	
Certification	CE: EN 60601-1-2:2015(V4.1), EN 60601-1:2006 + A11: 2011 + A1: 2013 + A12: 2014 Compliance VCCI: 2016-11, Class B (PSU with PSE/ Battery not include PSE) FCC: Part 18 Class B / UL: ANSI/AAMI ES60601-1:2012 (V3.2) By Project cUL: CAN/CSA-C22.2 No. 60601-1:2014 (V3.2) By Project / ISO 14971 / IEC62133	

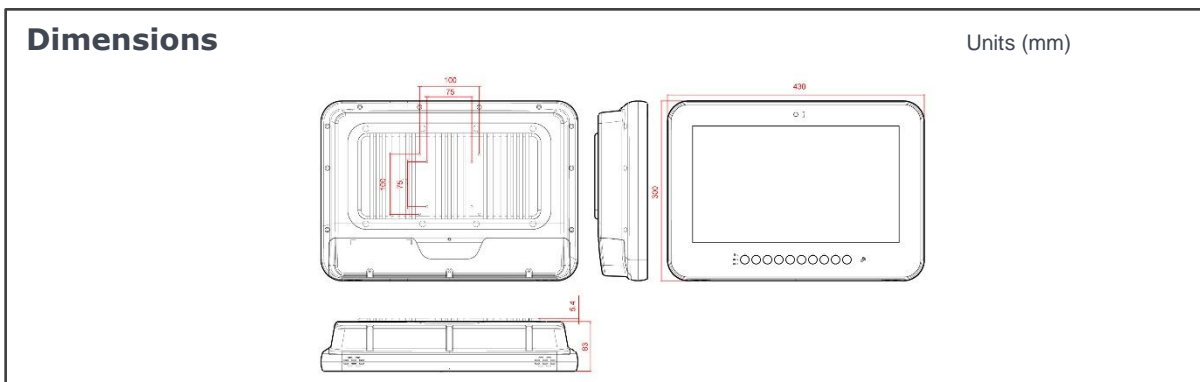

Major Options & Customization	
Options	<ul style="list-style-type: none"> ① 802.11 ac/a/b/g/n WLAN + Bluetooth module ② 802.11 ax/a/b/g/n WLAN + Bluetooth module (Wifi-6) ③ Auto focus 5M pixel webcam module ④ 2.5" SSD module ⑤ M.2 type 2280 module ⑥ RFID (13.56MHz) ⑦ TPM 2.0(SPI) module ⑧ Battery pack (100W max.) ⑨ COM3,4 ⑩ USB5,6 ⑪ Equipotential terminal pin ⑫ AG film ⑬ PCI-E x4 riser card ⑭ Full HD /4K capture card ⑮ Isolated 4KV module (optional order configuration) 4KV Isolated USB 2.0 (High speed) connector x 1 4KV Isolated gigaLAN connector x 1 4KV Isolated COM connector x 2 (one is RS-232/422/485, one is RS-232) ⑯ FHD panel (optional order configuration) ⑰ AC DC Power adapter 18V 100W (MDR Only) (optional order configuration) ⑱ GPIO capture card control solution
Customization	<ul style="list-style-type: none"> ① Tempered Glass ② Touch Panel with Anti-glare Coating ③ COM Ports Support 5V1A Output ④ Light sensor for LCD auto brightness (can't co-exist with webcam)

Order Information

Item	Configuration
WMP-15P-IP0A-i5	Core i5-1335U 4.60GHz / DDR5 8G RAM / M.2 128G SSD / P.cap touch / Support Vpro
WMP-15P-IP0A-i7	Core i7-1355U 5.00GHz / DDR5 8G RAM / M.2 128G SSD / P.cap touch / Support Vpro
WMP-15P-IP0A-i5UE	Core i5-1345UE 4.60GHz / DDR5 8G RAM / M.2 128G SSD / P.cap touch / Support Vpro
WMP-15P-IP0B-i5-ISO	Core i5-1335U 4.60GHz / DDR5 8G RAM / M.2 128G SSD / P.cap touch / Support Vpro / ISO
WMP-15P-IP0A-i5-FHD	Core i5-1335U 4.60GHz / DDR5 8G RAM / M.2 128G SSD / P.cap touch / Support Vpro / FHD

I/O ports (ISO)

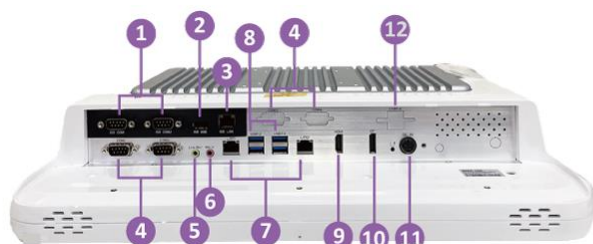

- | | | |
|---------------|---------------|----------------|
| ① iso COM x 2 | ⑤ Line-out | ⑨ HDMI x 1 |
| ② iso USB x 1 | ⑥ Mic-in | ⑩ DP x 1 |
| ③ iso LAN x 1 | ⑦ LAN x 2 | ⑪ DC-in |
| ④ COM x 4 | ⑧ USB 3.1 x 4 | ⑫ USB 5, 6 x 1 |