

SeaLINK REL-16

User Manual | 8208



SEALEVEL®

Contents

INTRODUCTION	3
<i>OTHER SEALEVEL USB DIGITAL I/O PRODUCTS</i>	3
BEFORE YOU GET STARTED	4
<i>WHAT'S INCLUDED</i>	4
<i>ADVISORY CONVENTIONS</i>	4
<i>OPTIONAL ITEMS</i>	5
SOFTWARE INSTALLATION	6
<i>WINDOWS INSTALLATION</i>	6
PHYSICAL INSTALLATION.....	7
PROGRAMMING THE SEALINK REL-16.....	8
<i>PROGRAMMING FOR WINDOWS</i>	8
<i>SAMPLES AND UTILITIES</i>	8
<i>DIGITAL I/O INTERFACE</i>	8
<i>SERIAL STRING</i>	8
<i>OUTPUT PORTS (REED RELAYS)</i>	9
<i>PIN ASSIGNMENTS (REMOVABLE TERMINAL BLOCK)</i>	9
ELECTRICAL CHARACTERISTICS.....	10
<i>FEATURES</i>	10
SPECIFICATIONS.....	11
<i>OUTPUT RELAYS</i>	11
<i>TEMPERATURE RANGE</i>	11
<i>MANUFACTURING</i>	11
EXAMPLE CIRCUITS	12
APPENDIX A – TROUBLESHOOTING.....	13
APPENDIX B – HOW TO GET ASSISTANCE	14
APPENDIX C – SILK SCREEN - 8208 PCB	15
APPENDIX D – COMPLIANCE NOTICES	16
<i>FEDERAL COMMUNICATIONS COMMISSION (FCC) STATEMENT</i>	16
WARRANTY.....	17

Introduction

The SeaLINK REL-16 provides 16 reed relays that can latch power, data, or other electronic signals for control applications. The adapter is USB 1.1 compliant.

The SEALINK REL-16 is designed to be used under Windows 98/ME/2000/XP. The Seal/O API (Application Programmer Interface) included on CD with the SEALINK REL-16 provides a variety of useful high-level function calls implemented in a Windows dynamic link library (DLL). This API gives access to the SeaLINK REL-16 I/O from Windows-based platforms such as Visual C++. In addition to the API, Seal/O includes an ActiveX control along with sample code and utilities to simplify software development.

Other Sealevel USB Digital I/O Products

Model No.	Part No.	Description
SeaLINK PLC-16	(P/N 8206)	- 8 Form C Relays/8 Opto-isolated Inputs
SeaLINK DIO-16	(P/N 8209)	- 8 Reed Relays/8 Opto-isolated Inputs
SeaLINK ISO-16	(P/N 8207)	- 16 Opto-isolated Inputs
SeaLINK PIO-48	(P/N 8203)	- 48 TTL Inputs/Outputs
SeaLINK PIO-96	(P/N 8205)	- 96 TTL Inputs/Outputs

Before You Get Started

What's Included

The SeaLINK REL-16 is shipped with the following items. If any of these items are missing or damaged, please contact Sealevel for replacement.

- **SeaLINK REL-16 Adapter**
- **USB A to B Cable, Part# CA179**

Advisory Conventions



Warning

The highest level of importance used to stress a condition where damage could result to the product, or the user could suffer serious injury.



Important

The middle level of importance used to highlight information that might not seem obvious or a situation that could cause the product to fail.



Note

The lowest level of importance used to provide background information, additional tips, or other non-critical facts that will not affect the use of the product.

Optional Items

Depending upon your application, you are likely to find one or more of the following items useful for interfacing the SeaLINK REL-16 to real-world signals. All items can be purchased from our website (www.sealevel.com) or by calling (864) 843-4343.

- **DIN Rail Clips (Part Number DR102)**

A pair of brackets, clips, and hardware necessary for DIN rail mounting the SeaLINK REL-16.

- **2U 19" Rack Tray (Part Number RK2U)**

Standard 2U rack tray for supporting SeaLINK and other devices.

- **Clamp for Rack Tray (Part Number RK-CLAMP)**

Metal clamp and necessary hardware to secure SeaLINK or other devices to the RK2U rack tray.

- **High Speed USB 2.0 4-Port Hub (Part Number HUB4)**

AC powered 4-port USB hub, AC adapter, and USB cable.

- **High Speed USB 2.0 7-Port Hub (Part Number HUB7)**

AC powered 7-port USB hub, AC adapter, and USB cable.

Software Installation

Windows Installation



Do not connect the SeaLINK REL-16 Adapter to the host USB device until the software has been fully installed.



Only users running Windows 7 or newer should utilize these instructions for accessing and installing the appropriate driver via Sealevel's website. If you are utilizing an operating system prior to Windows 7, please contact Sealevel by calling 864.843.4343 or emailing support@sealevel.com to receive access to the legacy driver download and installation instructions.

1. Begin by locating, selecting, and installing the correct software from the [Sealevel software driver database](#).
2. Select the Part Number (**#8208**) for your adapter from the listing.
3. Select the download for the SealO Classic for Windows ([Software: SealO Classic V5 - Windows - Sealevel](#).) The setup file will automatically detect the operating environment and install the proper components. Next (depending on your browser) select the 'Run this program from its current location' or 'Open' option. Follow the information presented on the screens that follow. During setup, the user may specify installation directories and other preferred configurations. This program also adds entries to the system registry that are necessary for specifying the operating parameters for each driver. An uninstall option is also available to remove SealO files and registry/INI file entries from the system.
4. Go to the "Add New Hardware Wizard" in the Control Panel.
5. When the Wizard asks if you want Windows to search for the new hardware, choose "No, I want to select the hardware from a list."
6. Scroll through the list of categorized hardware and select 'SealO Devices.' If this is the first SealO device you may need to select 'Other Devices' and 'Sealevel Systems, Inc.' instead of 'SealO Devices.'
7. Click "Next."
8. Select the card model and press "Next."
9. The Wizard will guide you through a few more informational prompts; continue to click "Next" until it is completed.
10. Your card's resource assignments may be adjusted through the Device Manager (if, for instance, you need to change the I/O port address Windows assigned when you installed the card).
11. Windows software installation is complete.



Windows NT is not USB aware and thus cannot support the SeaLINK REL-16.

Physical Installation

The SeaLINK REL-16 can be installed in any open USB port.



Do not plug the unit into a USB port until the software has been fully installed.

1. Simply connect the SeaLINK REL-16 to your USB port with the supplied cable.
2. The software drivers installed during setup will automatically recognize and configure the device.
3. You should see one or more “New Hardware Found” windows, indicating the actual device being created.
4. Next, view your system’s Device Manager.
5. You should have a new ‘SeaIO 8208’ in the Seal/O Device heading indicating the installation was successful.

The SeaLINK REL-16 is now ready for use.

Programming the SeaLINK REL-16

Sealevel's Seal/O software is available to assist in the development of reliable applications for the Sealevel Systems family of digital I/O adapters. Included in Sealevel's software are driver functions for use in accessing the I/O as well as helpful samples and utilities.

Programming for Windows

The Seal/O API (Application Programmer Interface) provides a variety of useful high-level function calls implemented in a Windows dynamic link library (DLL). The API is defined in the help file (Start/Programs/SealO/SealO Help) under "Application Programmers Interface". This help file also includes detailed information dealing with installation / removal of the software and information about latency, logic states, and device configuration.

For C language programmers we recommend using the API to access the SeaLINK REL-16. If you are programming in Visual Basic, using the ActiveX control included with Seal/O is advised.

Samples and Utilities

A variety of sample programs and utilities (both executable and source code) are included with Seal/O. Further documentation on these samples can be found by selecting "Start/Programs/SealO/Sample Application Description". Information about where the files are physically stored on your disk is also included in this same file.

Digital I/O Interface

The SeaLINK REL-16 provides two parallel input/output (I/O) ports. The ports are organized as ports A and B. The SeaLINK REL-16 is a line-powered device requiring a USB port capable of sourcing 500 mA.

Serial String

Each device has an eight digit alphanumeric serial string stored in non-volatile memory. On the Windows platforms, this number is used to give each unit a separate identity. This identity allows the device to be moved to any USB port or hub port on your computer while retaining its device number. If a device becomes damaged and is replaced the new device should be given the same serial string as the device it is replacing. This string is stored in an EEPROM along with other critical information. This EEPROM is read during enumeration. The device should not be unplugged during its enumeration due to remote possibility that the data in the EEPROM could be corrupted if power is removed during a read/write cycle to the EEPROM. Enumeration is complete when the LED is lit.

The control panel utility provides the capability to read or modify this string. However, setting the same string for two units connected to the same computer will cause the second unit to fail enumeration, and make it invisible to the operating system. Should this occur, unplug one unit, and set the serial string for the other unit to a different string.

Output Ports (Reed Relays)

Reed relays provide very high quality, long life, low power, dry contact switch closures. Reed relays are not suited for high current applications, or inductive loads. The relays are normally open, and close when energized. Writing a logic value of one or zero will change the state. Refer to the Application Programmers Interface for more information.

Pin Assignments (Removable Terminal Block)

Port A Bit	Port A Terminals
0	0,1
1	2,3
2	4,5
3	6,7
4	8,9
5	10,11
6	12,13
7	14,15

Port B Bit	Port B Terminals
0	0,1
1	2,3
2	4,5
3	6,7
4	8,9
5	10,11
6	12,13
7	14,15

Side Panel View Port A

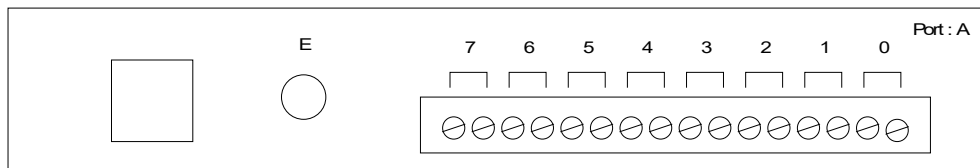

Side Panel View Port B

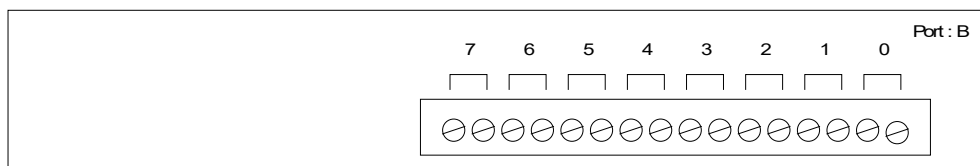

Electrical Characteristics

Features

- 16 SPST Reed relays
- Highly reliable 10 VA DIP reed relays utilized
- Removable screw terminals
- Powered by USB port

Specifications

Output Relays

Contact Max Power Rating	10 W
Contact Voltage Maximum	100 VDC/VAC
Contact Current Maximum	.5 A AC/DC RMS
Contact Resistance, Initial	.15 Ω
Rated Life	Low Load: 200 million closures Maximum Load: 100 million closures
Contact Speed	Operate: .5 mS Release: .5 mS Bounce: .5 mS
Maximum Operating Speed	600 Hz

Temperature Range

Operating	0°C - 70°C
Storage	-50°C - 105°C

Power Consumption

Supply line	+5 VDC
Rating	500 mA

Manufacturing

All Sealevel Systems Printed Circuit boards are built to UL 94V0 rating and are 100% electrically tested. These printed circuit boards are solder mask over bare copper or solder mask over tin nickel.

Example Circuits

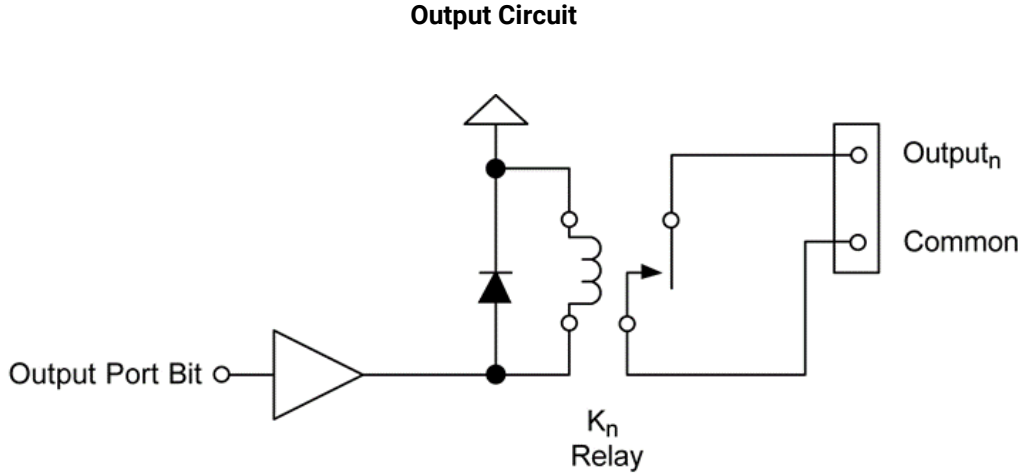

Appendix A – Troubleshooting

Following these simple steps can eliminate most common problems.

1. **Install software first.** After installing the software then proceed to adding the hardware. This places the required installation files in the correct locations.
2. Read this manual thoroughly before attempting to install the adapter in your system.
3. Use Device Manager under Windows to verify proper installation.
4. Use the SealIO Control Panel applet or the Device Manager's property page for card identification and configuration.

If these steps do not solve your problem, please call Sealevel Systems' Technical Support, (864) 843-4343. Our technical support is free and available Monday through Friday from 8:00 AM - 5:00 PM, Eastern Time. For email support contact support@sealevel.com.

Appendix B – How To Get Assistance

Begin by reading through the Trouble Shooting Guide in Appendix A. If assistance is still needed please see below.

When calling for technical assistance, please have your user manual and current adapter settings. If possible, please have the adapter installed in a computer ready to run diagnostics.

Sealevel Systems provides an FAQ section on its web site. Please refer to this to answer many common questions. This section can be found at <http://www.sealevel.com/faq.asp>.

Sealevel Systems maintains a Home page on the Internet. Our home page address is www.sealevel.com. The latest software updates, and newest manuals are available via our FTP site that can be accessed from our home page.

Technical support is available Monday to Friday from 8:00 AM to 5:00 PM, Eastern Time. Technical support can be reached at (864) 843-4343. For email support contact support@sealevel.com.

RETURN AUTHORIZATION MUST BE OBTAINED FROM SEALEVEL SYSTEMS BEFORE RETURNED MERCHANDISE WILL BE ACCEPTED. AUTHORIZATION CAN BE OBTAINED BY CALLING SEALEVEL SYSTEMS AND REQUESTING A RETURN MERCHANDISE AUTHORIZATION (RMA) NUMBER.

Appendix C – Silk Screen - 8208 PCB

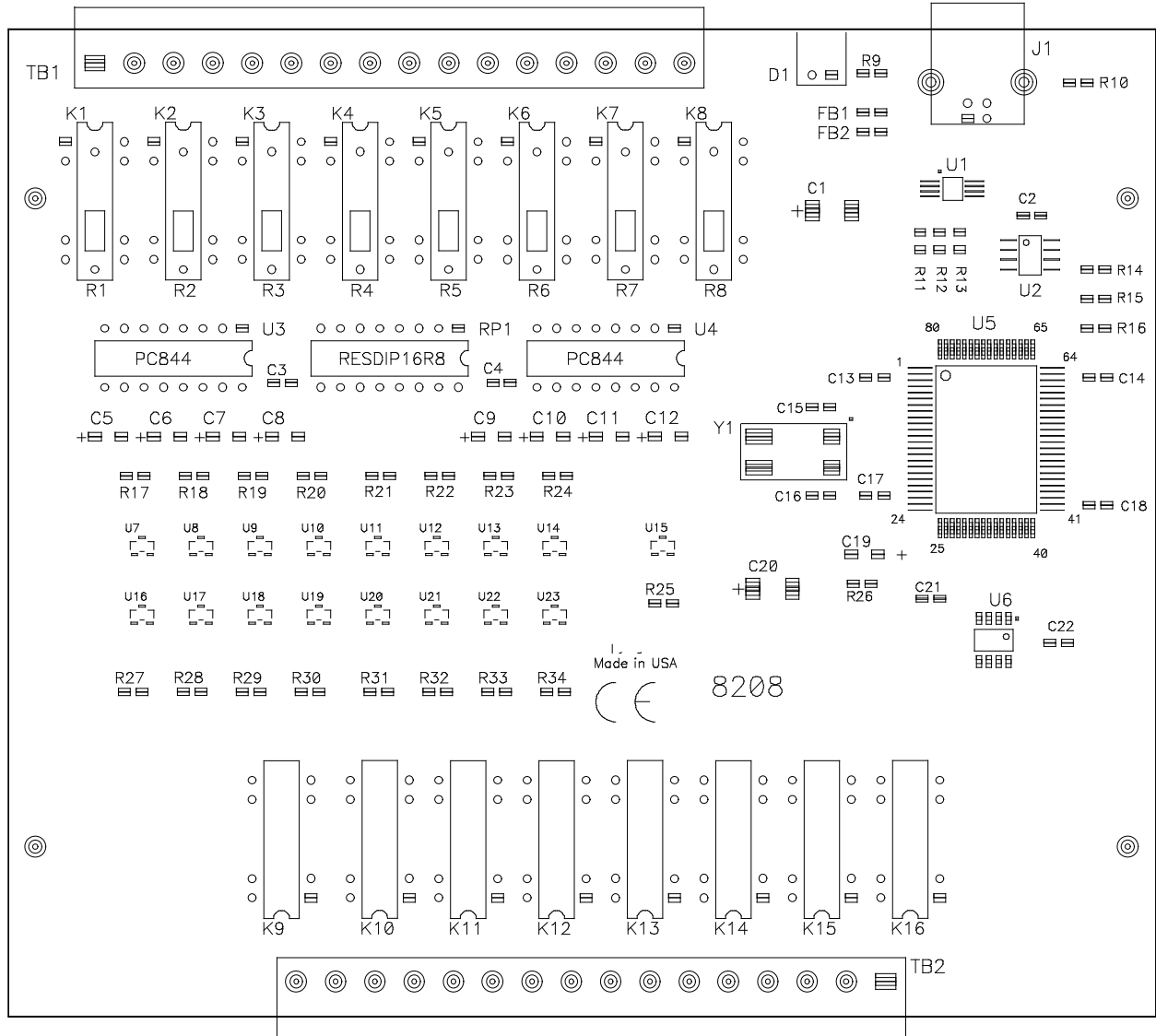

Appendix D – Compliance Notices

Federal Communications Commission (FCC) Statement



This equipment has been tested and found to comply with the limits for Class A digital device, pursuant to Part 15 of the FCC Rules. These limits are designed to provide reasonable protection against harmful interference when the equipment is operated in a commercial environment. This equipment generates, uses, and can radiate radio frequency energy and, if not installed and used in accordance with the instruction manual, may cause harmful interference to radio communications. Operation of this equipment in a residential area is likely to cause harmful interference in such case the user will be required to correct the interference at the users expense.

EMC Directive Statement



Products bearing the CE Label fulfill the requirements of the EMC directive (89/336/EEC) and of the low-voltage directive (73/23/EEC) issued by the European Commission. To obey these directives, the following European standards must be met:

- **EN55022 Class A** - “Limits and methods of measurement of radio interference characteristics of information technology equipment”
- **EN55024** – “Information technology equipment Immunity characteristics Limits and methods of measurement”.



This is a Class A Product. In a domestic environment, this product may cause radio interference in which case the user may be required to take adequate measures to prevent or correct the interference.



Always use cabling provided with this product if possible. If no cable is provided or if an alternate cable is required, use high quality shielded cabling to maintain compliance with FCC/EMC directives.

Warranty

Sealevel's commitment to providing the best I/O solutions is reflected in the Lifetime Warranty that is standard on all Sealevel manufactured I/O products. We are able to offer this warranty due to our control of manufacturing quality and the historically high reliability of our products in the field. Sealevel products are designed and manufactured at its Liberty, South Carolina facility, allowing direct control over product development, production, burn-in and testing. Sealevel achieved ISO-9001:2015 certification in 2018.

Warranty Policy

Sealevel Systems, Inc. (hereafter "Sealevel") warrants that the Product shall conform to and perform in accordance with published technical specifications and shall be free of defects in materials and workmanship for the warranty period. In the event of failure, Sealevel will repair or replace the product at Sealevel's sole discretion. Failures resulting from misapplication or misuse of the Product, failure to adhere to any specifications or instructions, or failure resulting from neglect, abuse, accidents, or acts of nature are not covered under this warranty.

Warranty service may be obtained by delivering the Product to Sealevel and providing proof of purchase. Customer agrees to ensure the Product or assume the risk of loss or damage in transit, to prepay shipping charges to Sealevel, and to use the original shipping container or equivalent. Warranty is valid only for original purchaser and is not transferable.

This warranty applies to Sealevel manufactured Product. Product purchased through Sealevel but manufactured by a third party will retain the original manufacturer's warranty.

Non-Warranty Repair/Retest

Products returned due to damage or misuse and Products retested with no problem found are subject to repair/retest charges. A purchase order or credit card number and authorization must be provided in order to obtain an RMA (Return Merchandise Authorization) number prior to returning Product.

How to obtain an RMA (Return Merchandise Authorization)

If you need to return a product for warranty or non-warranty repair, you must first obtain an RMA number. Please contact Sealevel Systems, Inc. Technical Support for assistance:

Available	Monday – Friday, 8:00AM to 5:00PM EST
Phone	864-843-4343
Email	support@sealevel.com

Trademarks

Sealevel Systems, Incorporated acknowledges that all trademarks referenced in this manual are the service mark, trademark, or registered trademark of the respective company.