

PPC-F H81 Series



Intelligent Industrial Panel PC

Features

- Support IEI iRIS-2400 IEI remote intelligent solution
- Scalable Intel® H81 chipset supports LGA1150 Intel® 4th generation Core™ i7/i5, Pentium® or Celeron® processor with up to 65W TDP
- Robust IP65 aluminum front bezel
- Aesthetic ultra-thin bezel for seamless panel mount installation
- Projected capacitive multi-touch
- Dual full-size PCIe Mini card expansion



Specifications

| Model | | PPC-F15A | PPC-F17A |
|---------------------------------|---------------------------------------|---|--|
| LCD | LCD Display | 15" (4:3) | 17" (5:4) |
| | Max. Resolution | 1024 (W) x 768 (H) | 1280 (W) x 1024 (H) |
| | Brightness (cd/m ²) | 450 | 350 |
| | Contrast Ratio | 800 : 1 | 800 : 1 |
| | LCD Color | 16.2M | 16.7M |
| | Pixel Pitch (mm) | 0.297 x 0.297 | 0.26 x 0.26 |
| | Viewing Angle (H-V) | 160° / 150° | 170° / 160° |
| | Backlight MTBF (hrs) | 70000 | 50000 |
| Motherboard | SBC Model | FPPCMB-H81-R10 | |
| | CPU | LGA1150 Intel® 4th generation Core™ i7/i5, Pentium® or Celeron® processor with up to 65W TDP | |
| | Chipset | Intel® H81 | |
| | RAM | Support 2 x 204-pin 1066/1333/1600 MHz dual-channel DDR3 SO-DIMM slots (max. 16GB) | |
| Touch | Touchscreen & Controller | 5-wire resistive single touch window, 3H/Penmount 9000 (Anti-glare Surface) 10-point Projected capacitive touch window, 6H/EETI EXC3188 (Anti-UV, Anti-glare Surface) | |
| Input Interfaces | I/O Ports & Switch | 2 x RJ-45 LAN Port 2 x USB 3.2 Gen 1 (5Gb/s) 4 x USB 2.0 1 x HDMI output | 4 x RS-232 1 x RS-422/485 1 x MIC-in 1 x Line-out |
| | Expansion | 1 x Full-size/half-size PCIe Mini card (PCIe and USB signal) 1 x Full-size/half-size PCIe Mini card (PCIe, USB and mSATA signal) | |
| Wireless LAN | | 802.11 b/g/n (optional) | |
| Storage | | 1 x 2.5" HDD/SSD drive bay 1 x mSATA | |
| iRIS Remote Management Solution | | iRIS-2400 (optional) | |
| Physical | Construction Material | Aluminum front cover and sheet metal rear cover | |
| | Mounting | Panel mount, rack mount, 100x100 VESA mount | |
| | Enclosure Color | Black C | |
| | Dimensions (mm) | 303 x 378.5 x 68.7 | 341.4 x 408.4 x 73.8 |
| | Cutout Dimensions (mm) | 285.6 x 361.1 | 323 x 390 |
| | Net/ Gross Weight (kg) | 5.6/ 8.3 | 7.5/10.7 |
| Environment | Operating Temperature (with air flow) | -10°C ~ 50°C | |
| | Storage Temperature | -20°C ~ 60°C | |
| | Humidity | 10% to 95% (non-condensing) | |
| | IP Level | Front IP 65 | |
| Safety and EMC | | CE & FCC certified | |
| Power Supply | AC Input | AC input ATX power supply - P/N: 63030-010220-100-RS - 220W power supply - Input: 90VAC-264VAC, 50/60Hz - Output (max.): 3.3V@10A, 5V@14A, 12V@14A, -12V@0.3A | |
| Power Consumption | | 80W | 100W |

Ordering Information

| Part No. | Description |
|----------|---|
| 15" | PPC-F15AA-H81i-P/4G/PC-R23 15" 450 cd/m ² XGA Panel PC with Intel® H81 chipset, Intel® Pentium® Processor G3420 (3M Cache, 3.20 GHz), TDP 53W, 2GB RAM*2, support iRIS-2400, black color, PSU ACE-A622C, projective capacitive touch window with AG coating, R23 |
| | PPC-F15AA-H81i-i5/4G/PC-R23 15" 450 cd/m ² XGA Panel PC with Intel® H81 chipset, Core i5 Quad Core i5-4570S Processor (6M Cache, up to 3.60GHz), TDP 65W, 2GB RAM*2, support iRIS-2400, black color, PSU ACE-A622C, PCAP touch window with AG coating, R23 |
| | PPC-F15AA-H81i-P/4G/R-R23 15" 450 cd/m ² XGA Panel PC with Intel® H81 chipset, Intel® Pentium® Processor G3420 (3M Cache, 3.20 GHz), TDP 53W, 2GB RAM*2, support iRIS-2400, black color, PSU ACE-A622C, resistive touch window with AG coating, R23 |
| | PPC-F15AA-H81i-i5/4G/R-R23 15" 450 cd/m ² XGA Panel PC with Intel® H81 chipset, Core i5 Quad Core i5-4570S Processor (6M Cache, up to 3.60GHz), TDP 65W, 2GB RAM*2, support iRIS-2400, black color, PSU ACE-A622C, resistive touch window with AG coating, R23 |
| 17" | PPC-F17AA-H81i-P/4G/PC-R14 17" 350 cd/m ² SXGA Panel PC with Intel® H81 chipset, Intel® Pentium® Processor G3420 (3M Cache, 3.20 GHz), TDP 53W, 2GB RAM*2, support iRIS-2400, black color, PSU ACE-A622C, projective capacitive touch window with AG coating, R14 |
| | PPC-F17AA-H81i-i5/4G/PC-R14 17" 350 cd/m ² SXGA Panel PC with Intel® H81 chipset, Core i5 Quad Core i5-4570S Processor (6M Cache, up to 3.60GHz), TDP 65W, 2GB RAM*2, support iRIS-2400, black color, PSU ACE-622C, projective capacitive touch window with AG coating, R14 |
| | PPC-F17AA-H81i-P/4G/R-R14 17" 350 cd/m ² SXGA Panel PC with Intel® H81 chipset, Intel® Pentium® Processor G3420 (3M Cache, 3.20 GHz), TDP 53W, 2GB RAM*2, support iRIS-2400, black color, PSU ACE-A622C, resistive touch window with AG coating, R14 |
| | PPC-F17AA-H81i-i5/4G/R-R14 17" 350 cd/m ² SXGA Panel PC with Intel® H81 chipset, Core i5 Quad Core i5-4570S Processor (6M Cache, up to 3.60 GHz), TDP 65W, 2GB RAM*2, support iRIS-2400, black color, PSU ACE-622C, resistive touch window with AG coating, R14 |

Options

| Item | PPC-F15A | PPC-F17A |
|---|--|--------------------------------|
| Arm | ARM-31-RS | ARM-31-RS |
| Stand | STAND-A21 STAND-A19-RS STAND-C19-R10 | STAND-C19-R10 STAND-A21-R10 |
| Wall Mount Kit | WK-190MS-R10 | |
| Panel Mount Kit | FPK-04-R10 | |
| Rack Mount Kit | FRK15-R10 | FRK17-R10 |
| iRIS (IEI Remote Intelligent System) Kit | iRIS-2400-R10 | |

Packing List

| Item | Q'ty | Remark |
|------------|------|----------------------------|
| Power Cord | 1 | Depends on shipping region |
| Screw Kit | 1 | |

PPC-F15A
Fully Integrated I/O

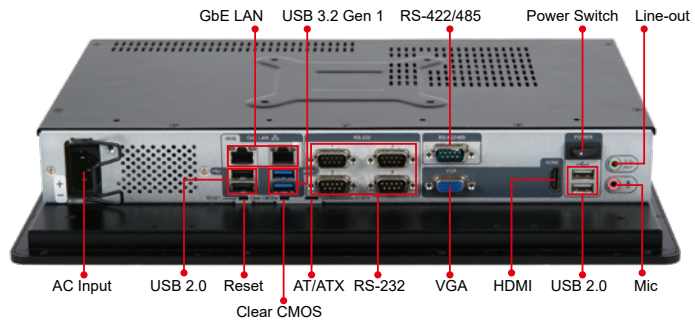

PPC-F17A
Fully Integrated I/O

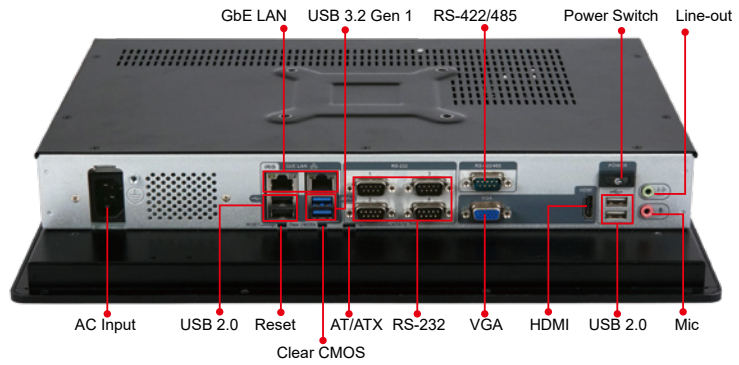

PPC-F15A Dimensions
(Unit: mm)

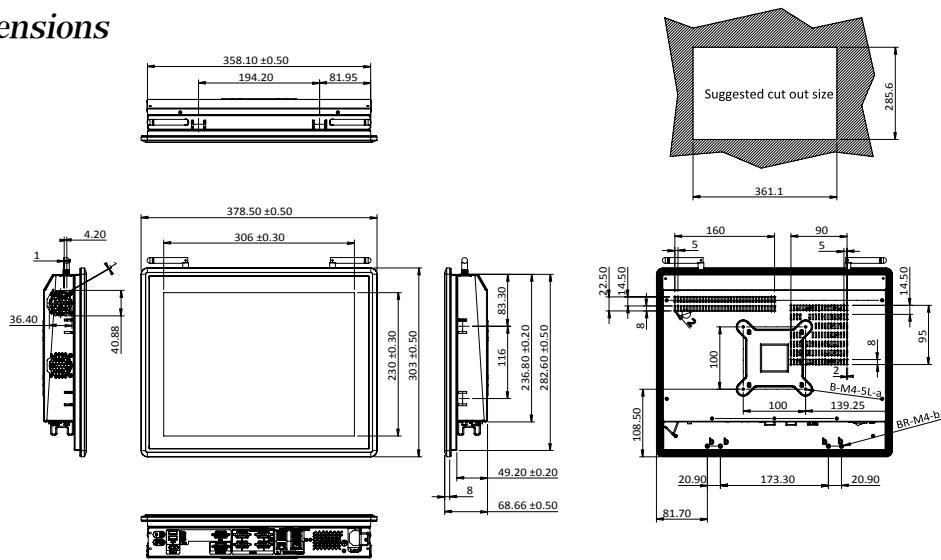

PPC-F17A Dimensions
(Unit: mm)

