

# CUSTOMER DRAWING

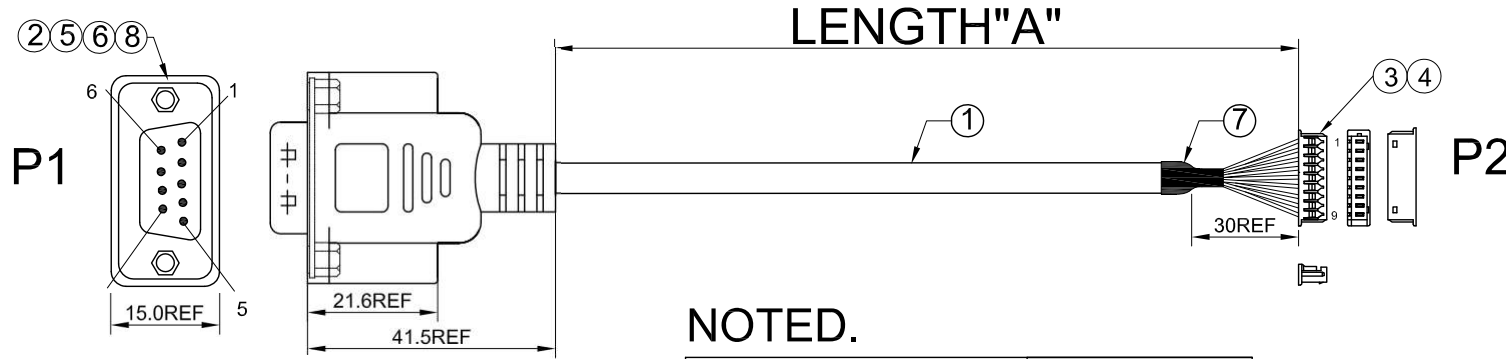

**D-SUB 9P MALE(公頭/後鉚螺母)**  
再附上2支六角螺母, 客戶組裝時可鎖固。

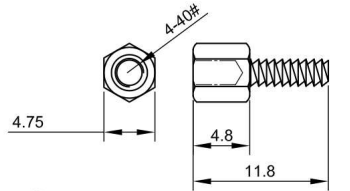

⑨ HEX SCREW 4-40#

## NOTED.

TC&C PART NO.	LENGTH"A"
T107027091802-1	150±10mm

## PACKAGE :

每50PCS產品&100PCS(袋)螺絲如下圖裝入PE袋。

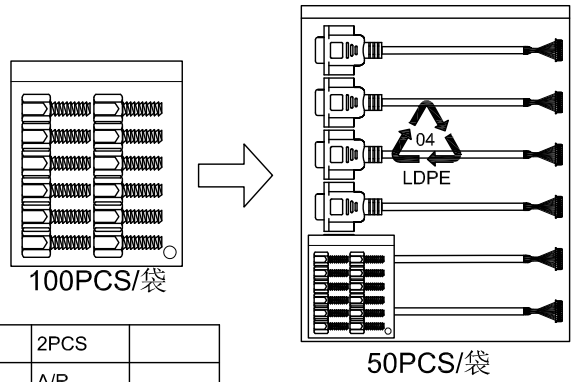

P1		P2
1	brown(棕)	1
6	blue(藍)	2
2	red(紅)	3
7	gray(灰)	4
3	orange(橙)	5
8	purple(紫)	6
4	yellow(黃)	7
9	green(綠)	8
5	black(黑)	9
SHELL鐵殼		地線

## WIRING TABLE

- NOTE:
- 1.OPEN/SHORT TEST:100%;
  - 2.CONDUCTOR RESISTANCE:5Ω;
  - 3.INSULATION RESISTANCE:20MΩ;
  - 4.HI-POT TEST:300V/DC;
  - 5.ALL MATERIALS MUST ACCORD WITH RoHS;

ITEM	PART NUMBER	DESCRIPTION	Q'TY	REMARK
9	T820001041070Z6	SCREW 六角螺母 4-40# 4.75*11.8	2PCS	
8	T73210080000V10	H.S,TUBE OD:0.8	A/R	
7	T73210080000V10	H.S,TUBE OD:6.0	A/R	
6	T70021006060101	LDPE 0405 JAPAN NUC 低密度 耐溫 120度	G	
5	T70011102060106	35P PVC FOR OVERMOLD BEIGE	G	
4	T81350322A1F7	TERMINAL PH 1.25 #28-32 XY:KB915-10T2B 磷銅鍍錫	9PCS	
3	T500313109002F7	HSG PH1.25 1X9P WHITE VXY:KB915-10H3A	1PC	
2	T502712209231GI	D-SUB 9P/M BLACK G/F 通孔 後鉚螺母	1PC	
1	T60-RK-YX-071	UL2725 28#*9C+AL BLACK,PVC,OD=4.5MM	A/R	

TOLERANCE UNIT( mm)	APPROVALS	DATE	TITLE			
X. ±0.30	DRAWN Winki	08/28/2018	DB 9P(黑色)+THUMB SCREW MALE TO HSG 1.25 1*9P , UL2464 26#X9C+DA BLACK			
X.X ±0.25	CHECKED Jenny	08/28/2018				
X.XX ±0.15	APPROVED Johnson	08/28/2018				
X.XXX ±0.08			SCALE N.A.	PART NO.	DRAWING NO.	REV.
ANGULAR ±2°			SHEET 1 OF 1	T107027091802-X	T107027091802-X A	A
UNLESS OTHERWISE SPECIFIED			CUSTOMER CODE	CUSTOMER PART NO.		

UNIT MM