

Note:

1. Material: SECC, Thickness: 2.0mm
2. Surface treatment: Painting Black C All Area.
(point textured painting)
3. Break all sharp edges & corners free from burrs.
finished part must be free of all deburring shavings
and particles.
4. Unspecified radius is R=2mm.
5. Unspecified internal radius is R=1.0mm.
6. check point: (A) ~ (D) .

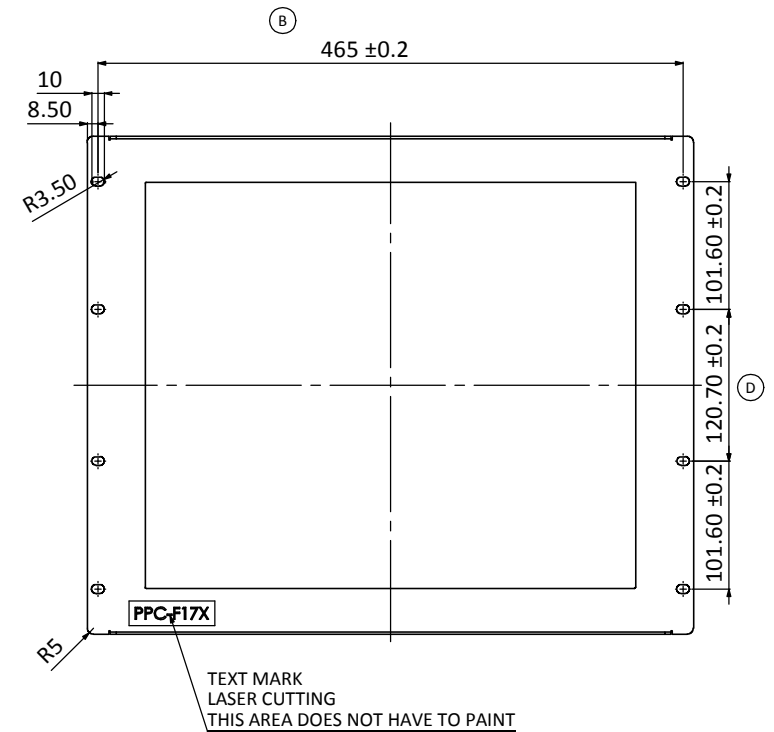
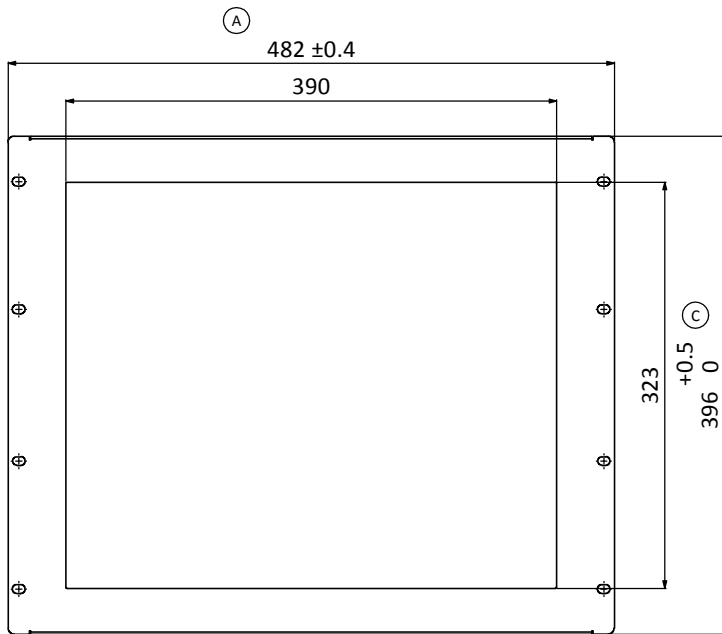

Ordering Information

Part No.	Description
FRK17C-R10	Rack Mounting Kit for PPC-F17C/FLEX-PLKIT-F17