

DIN PLUG	POLARITY
P2	VO(+)
P4	
SHIELD	
P1	GND(-)
P3	

ITEM	PART NAME	COLOR
1	COVER	BLACK
2	CHASSIS	BLACK
3	POWER CORD	BLACK
4	SOCKET	BLACK
5	LABEL	BLACK

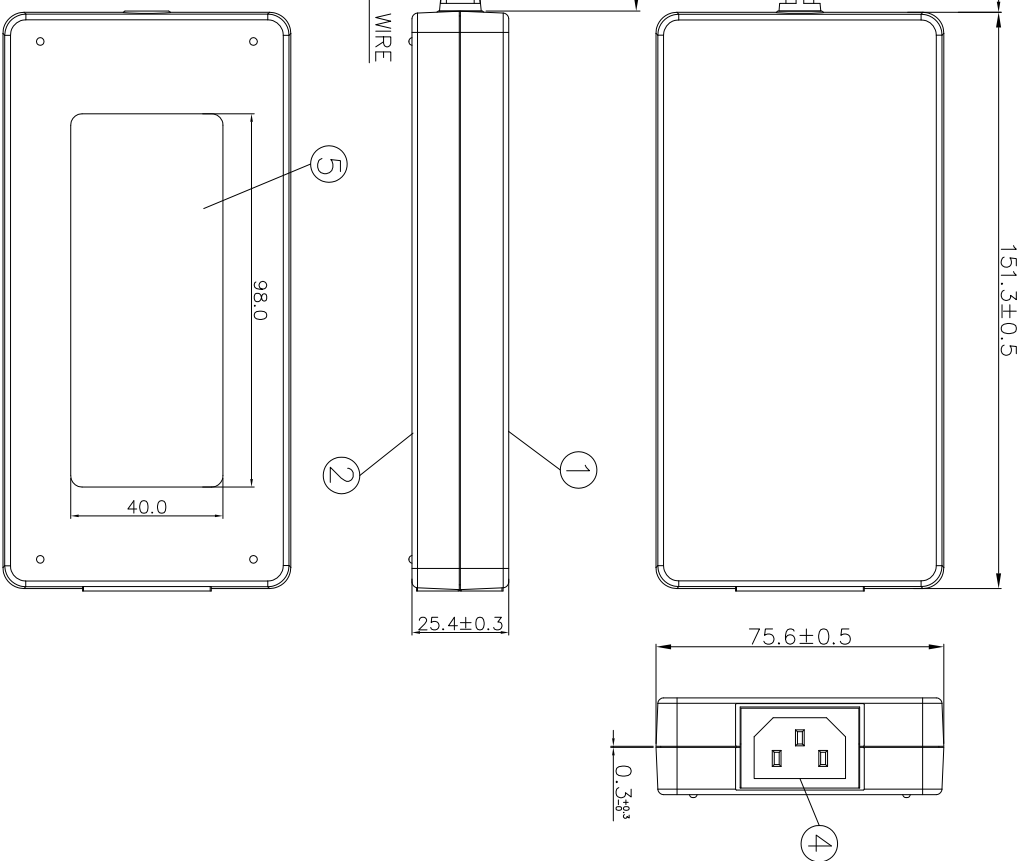

P/N:9NA1504811

MODEL NO. : FSP 150-ABAN3(1220001)	TITLE: Physical Dimension	SHEET: 1 OF 1	REV:01
------------------------------------	---------------------------	---------------	--------

R&D3 Division

PE

ME

DATE

L.J

ABBY

ABBY

2018-11-22

INTERIOR COUNTERSIGN:

DIMENSIONAL TOLERANCES

HOLES : ±0.05 ANGLES : ±0.5°

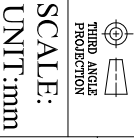

()	()	(V)	()
<30	±0.2	UP-100	±0.2
30-100	±0.3	100-150	±0.25
>100-300	±0.5	150-300	±0.3
>300-500	±0.6	300-500	±0.4
ABOVE 500	±0.8	500-700	±0.5
		700-900	±0.6
		900-1200	±0.8
		1200-1500	±1.0
		1500-2000	±1.2
		2000-3000	±1.5
		3000-4000	±2.0
		4000-5000	±2.5
		5000-7000	±3.0
		7000-10000	±4.0
		10000-15000	±5.0
		15000-20000	±6.0
		20000-30000	±8.0
		30000-40000	±10.0
		40000-50000	±12.0
		50000-70000	±15.0
		70000-100000	±20.0



FSP GROUP INC.
全漢企業股份有限公司/全汉企业股份有限公司

Switching Power Adapter (電源供應器/电源适配器/직류전원장치)
Model No (型號/型号/모델명): FSP150-ABAN3
AC Input (輸入/输入/입력): 100-240V~, 2.0A, 50-60Hz
DC Output (輸出/输出/출력): 19V 7.89A
CAUTION (警告/警告/주의사항):
For use with Information Technology Equipment.
(適用於資訊類產品/适用于资讯类产品)
(본 제품은 실내용이며, IT제품에 사용하십시오.)
ATTENTIONS:
Pour les équipements de traitement de l'information.
ATTENTION:
Nur zur Verwendung mit informationstechnischen Einrichtungen.

CAN ICES-3 (B)/NMB-3(B)
This device complies with Part 15 of the FCC Rules.
Operation is subject to the following two conditions:
(1) this device may not cause harmful interference, and
(2) this device must accept any interference received,
including interference that may cause undesired operation.

MADE IN CHINA ~
(中國製造/中国制造)

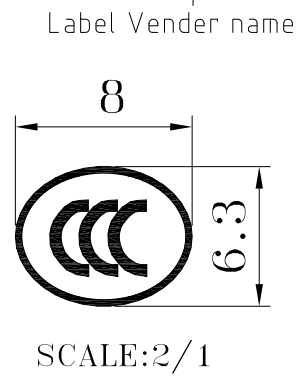
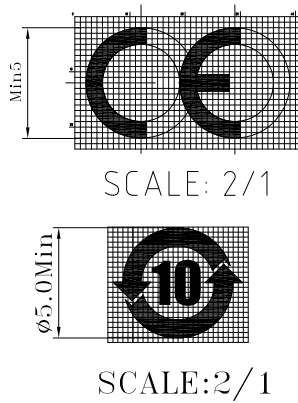
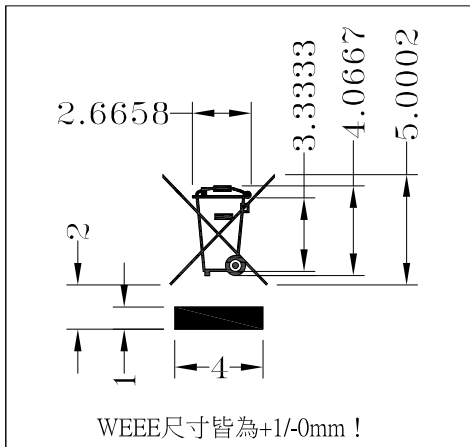

NOTES:

- MATERIAL: WHITE POLYESTER + MYLAR COATING(半霧面), t=0.15±0.05mm.
ADHESIVE: # K.K. NO. 9 OR EQUIVALENT.
- BACKGROUND'S COLOR: BLACK.
WORD'S COLOR: WHITE
- "~" LABEL VENDER IN ENGLISH NAME, 2 LETTERS.
- LABEL MUST BE DIE CUT PROPERLY AS PER DIMENSION.
- LABEL MUST BE UL RECOGNIZED: PGDQ2 OR PGJ12 AND CSA CERTIFIED:
Plastic Group III(polycarbonate).
- THE LABEL IS SUPPOSED TO BE PASTED ON PC CASE EVENLY AND PROPERLY
IT'S NOT ALLOWED TO HAVE ANY BULGE HAPPEN ON THE LABEL AFTER BE BURNT
IN 72 HRS IN OVEN WHICH TEMPERATURE IS 100°C.
- DIMENSIONS MARKED * MARK MUST BE INSPECTED AND CONTROLLED STRICTLY BY IQC.
- THE PLASTIC MATERIAL OF APPLICATION SURFACE FOR THIS LABEL IS PC.
- ALL SPECIFICATION MUST BEEN APPROVED BY DESIGN ENGINEER.
- UNFOUNDED TOLERANCE: ±0.2mm.
- THE FINISHED LABEL GOODS SHOULD ALL THE SAME AS THIS DRAWING;
INCLUDING: FONT TYPE, SYMBOLS, CONTENT, SIZE, POSITION,ETC.
- 黏貼於PC塑膠材質,表面屬於光面或是鏡面.

SCALE:
UNIT: mm

P/N.:6LL1975701GP

MODEL NO. :	FSP150-ABAN3	TITLE:	SPEC LABEL	SHEET: 1 OF 1	REV: 01
R&D3 Division	PE		ME	DATE	
L.J	ABBY		ABBY	2018/11/22	
INTERIOR COUNTERSIGN:					