



IEI Technology Corp .



MODEL:
AFL-xxA-N26

**Fanless All-in-one Panel PC with 1.6 GHz Intel® Atom™ Processor
TFT LCD, Wireless LAN, Touch Screen,
RS-232/422/485 and IP 64 Protection**

User Manual

Rev. 1.01 - 26 March, 2013



Revision

Date	Version	Changes
26 March, 2013	1.01	Updated supported memory frequency
9 November, 2012	1.00	Initial release

Copyright

COPYRIGHT NOTICE

The information in this document is subject to change without prior notice in order to improve reliability, design and function and does not represent a commitment on the part of the manufacturer.

In no event will the manufacturer be liable for direct, indirect, special, incidental, or consequential damages arising out of the use or inability to use the product or documentation, even if advised of the possibility of such damages.

This document contains proprietary information protected by copyright. All rights are reserved. No part of this manual may be reproduced by any mechanical, electronic, or other means in any form without prior written permission of the manufacturer.

TRADEMARKS

All registered trademarks and product names mentioned herein are used for identification purposes only and may be trademarks and/or registered trademarks of their respective owners.

**WARNING:**

This equipment has been tested and found to comply with the limits for a Class A and Class B digital device, pursuant to part 15 of the FCC Rules. These limits are designed to provide reasonable protection against harmful interference in a residential installation.

This equipment generates, uses and can radiate radio frequency energy and, if not installed and used in accordance with the instructions, may cause harmful interference to radio communications.

However, there is no guarantee that interference will not occur in a particular installation. If this equipment does cause harmful interference to radio or television reception, which can be determined by turning the equipment off and on, the user is encouraged to try to correct the interference by one or more of the following measures:

- Reorient or relocate the receiving antenna.
- Increase the separation between the equipment and receiver.
- Connect the equipment into an outlet on a circuit different from that to which the receiver is connected.
- Consult the dealer or an experienced radio/TV technician for help.

You are cautioned that any change or modifications to the equipment not expressly approve by the party responsible for compliance could void your authority to operate such equipment.

Table of Contents

1 INTRODUCTION.....	15
1.1 OVERVIEW.....	16
1.1.1 Features and Model Variations.....	16
1.1.2 Applications	17
1.2 EXTERNAL OVERVIEW.....	17
1.2.1 Front Panel	18
1.2.2 Rear Panel	18
1.2.3 I/O Interface Panel	19
1.2.4 Top Panel and Side Panels.....	20
1.3 DIMENSIONS.....	21
1.3.1 AFL-W07A-N26 Dimensions.....	21
1.3.2 AFL-08A-N26 Dimensions.....	22
1.3.3 AFL-10A-N26 Dimensions.....	23
1.3.4 AFL-12A-N26 Dimensions.....	24
1.4 INTERNAL OVERVIEW.....	25
1.5 SYSTEM SPECIFICATIONS.....	25
2 UNPACKING	27
2.1 UNPACKING.....	28
2.1.1 Packing List	29
3 INSTALLATION	32
3.1 ANTI-STATIC PRECAUTIONS	33
3.2 INSTALLATION PRECAUTIONS	33
3.3 INSTALLATION AND CONFIGURATION STEPS	34
3.4 OPENING THE SYSTEM.....	34
3.5 MSATA SSD INSTALLATION.....	36
3.6 HDD INSTALLATION (AF-12A-N26 ONLY).....	39
3.7 AT/ATX MODE SELECTION	41
3.7.1 AT Power Mode.....	41
3.7.2 ATX Power Mode	42

3.8 JUMPER SETTINGS	42
3.8.1 Access the Jumpers	43
3.8.2 Preconfigured Jumpers	43
3.8.3 Clear CMOS Jumper.....	44
3.8.4 COM3 Port Pin 9 Select	45
3.8.5 RS-232/422/485 Serial Port Select Jumper	46
3.8.5.1 COM4 RS-422 and RS-485 Pinouts	47
3.9 MOUNTING THE SYSTEM	48
3.9.1 Wall Mounting.....	48
3.9.2 Panel Mounting.....	51
3.9.3 Arm Mounting	54
3.9.4 Cabinet and Rack Installation	55
3.10 BOTTOM PANEL CONNECTORS.....	57
3.10.1 LAN Connection.....	57
3.10.2 Serial Device Connection (DB-9).....	58
3.10.3 RJ-45 to DB-9 Serial Cable Connection.....	60
3.10.4 USB Device Connection.....	60
4 SYSTEM MAINTENANCE	62
4.1 SYSTEM MAINTENANCE INTRODUCTION	63
4.2 ANTI-STATIC PRECAUTIONS	63
4.3 TURN OFF THE POWER	64
4.4 OPENING THE SYSTEM.....	64
4.5 REPLACING COMPONENTS.....	64
4.5.1 Memory Module Replacement	64
4.5.2 WLAN Module Replacement	66
4.6 REINSTALLING THE COVERS	67
5 AMI BIOS SETUP	68
5.1 INTRODUCTION.....	69
5.1.1 Starting Setup.....	69
5.1.2 Using Setup	69
5.1.3 Getting Help.....	70
5.1.4 Unable to Reboot After Configuration Changes.....	70
5.1.5 BIOS Menu Bar.....	70

AFL-xxA-N26 Series Panel PC

5.2 MAIN.....	71
5.3 ADVANCED.....	72
5.3.1 ACPI Settings.....	73
5.3.2 RTC Wake Settings.....	74
5.3.3 CPU Configuration.....	75
5.3.4 IDE Configuration.....	77
5.3.5 USB Configuration.....	78
5.3.6 F81866 Super IO Configuration.....	79
5.3.6.1 Serial Port n Configuration.....	80
5.3.7 F81866 H/W Monitor.....	83
5.3.7.1 Smart Fan Mode Configuration.....	83
5.3.8 Serial Port Console Redirection.....	85
5.4 iEi FEATURE.....	86
5.5 CHIPSET.....	87
5.5.1 Host Bridge Configuration.....	88
5.5.1.1 Intel IGD Configuration.....	88
5.5.2 South Bridge Configuration.....	89
5.6 BOOT.....	91
5.7 SECURITY.....	93
5.8 SAVE & EXIT.....	94
6 SOFTWARE DRIVERS.....	96
6.1 AVAILABLE SOFTWARE DRIVERS.....	97
6.2 STARTING THE DRIVER PROGRAM.....	97
6.3 CHIPSET DRIVER INSTALLATION.....	98
6.4 VGA DRIVER INSTALLATION.....	102
6.5 LAN DRIVER INSTALLATION.....	107
6.6 AUDIO DRIVER INSTALLATION.....	109
6.7 TOUCH SCREEN DRIVER.....	112
6.8 WIRELESS DRIVER.....	114
7 INTERFACE CONNECTORS.....	118
7.1 PERIPHERAL INTERFACE CONNECTORS.....	119
7.2 INTERNAL PERIPHERAL CONNECTORS.....	120
7.2.1 Audio Speaker-out Connector (CN3).....	122

7.2.2 Audio MIC-in Connector (MIC1)	122
7.2.3 Audio DMIC-in Connector (DMIC1).....	122
7.2.4 Battery Connector (CN1).....	123
7.2.5 COM2 Connector (COM2)	123
7.2.6 CPU Fan Connector (CPU_FAN1).....	123
7.2.7 DIO Connector (DIO1).....	123
7.2.8 HDD LED Connector (HDD_CN1).....	124
7.2.9 I2C Connector (CN4).....	124
7.2.10 LVDS Connector (LVDS1)	124
7.2.11 LVDS Backlight Connector (INVERTER1).....	125
7.2.12 MCU Connector (JP8).....	125
7.2.13 MCU Connector (HOTKEY_CN1)	125
7.2.14 PCIe Mini Slot (M_PCIE1).....	126
7.2.15 PCIe Mini Slot (M_PCIE2).....	127
7.2.16 Power LED Connector (PW_LED1).....	128
7.2.17 Power Button Connector (PW_BTN1).....	128
7.2.18 SATA Power Connector (SATA_PWR1).....	128
7.2.19 SATA Connector (SATA1).....	128
7.2.20 Touch Panel Connector (TS1).....	129
7.2.21 TTL Panel Connector (CN6).....	129
7.2.22 USB Connector (USB1)	130
7.2.23 USB Connector (USB2)	130
7.2.24 USB Connector (USB3)	131
7.2.25 USB2 and USB3 Power Connector (JP18).....	131
7.3 EXTERNAL INTERFACE PANEL CONNECTORS	131
7.3.1 Audio Line-out Connector (AUX1)	132
7.3.2 Ethernet Connector (LAN1, LAN2).....	132
7.3.3 Power Connector (CN5)	132
7.3.4 RS-232 Serial Port (COM1, RJ-45).....	133
7.3.5 RS-232/422/485 Serial Port (COM3/COM4, DB-9).....	133
7.3.6 Reset Button Connector (RST1).....	134
7.3.7 USB 2.0 Connectors (USB4).....	134
7.3.8 VGA Connector (VGA1).....	134
7.4 PRECONFIGURED JUMPER SETTINGS.....	135
7.4.1 Backlight Voltage Selection Jumper (J_BLI).....	135

AFL-xxA-N26 Series Panel PC

7.4.2 Inverter ADJ Power Selection Jumper (JP6).....	135
7.4.3 Inverter Power Selection Jumper (JP1).....	135
7.4.4 LVDS Panel Voltage Selection Jumper (J_VLVDS1).....	136
7.4.5 Touchscreen Selection Jumper (J1).....	136
A SAFETY PRECAUTIONS	137
A.1 SAFETY PRECAUTIONS	138
A.1.1 General Safety Precautions	138
A.1.2 Anti-static Precautions	139
A.1.3 Product Disposal	140
A.2 MAINTENANCE AND CLEANING PRECAUTIONS	140
A.2.1 Maintenance and Cleaning.....	140
A.2.2 Cleaning Tools	141
B BIOS CONFIGURATION OPTIONS.....	143
B.1 BIOS CONFIGURATION OPTIONS	144
C WATCHDOG TIMER	146
D HAZARDOUS MATERIALS DISCLOSURE	149
D.1 HAZARDOUS MATERIAL DISCLOSURE TABLE FOR IPB PRODUCTS CERTIFIED AS ROHS COMPLIANT UNDER 2002/95/EC WITHOUT MERCURY	150

List of Figures

Figure 1-1: AFOLUX AFL-xxA-N26 Flat Panel PC.....	16
Figure 1-2: AFL-xxA-N26 Front View	18
Figure 1-3: AFL-xxA-N26 Rear View	18
Figure 1-4: AFL-10A-N26 I/O Interface Connector Panel	19
Figure 1-5: AFL-12A-N26 I/O Interface Connector Panel	20
Figure 1-6: AFL-xxA-N26 Top View	20
Figure 1-7: AFL-10A-N26 Side View	20
Figure 1-8: AFL-W07A-N26 Dimensions (mm).....	21
Figure 1-9: AFL-08A-N26 Dimensions (mm)	22
Figure 1-10: AFL-10A-N26 Dimensions (mm)	23
Figure 1-11: AFL-12A-N26 Dimensions (mm)	24
Figure 3-1: Back Cover Retention Screws	35
Figure 3-2: AFL-W07A-N26 Aluminum Back Cover Retention Screws	35
Figure 3-3: AFL-08A-N26 Aluminum Back Cover Retention Screws.....	35
Figure 3-4: AFL-10A-N26 Aluminum Back Cover Retention Screws.....	36
Figure 3-5: AFL-12A-N26 Aluminum Back Cover Retention Screws.....	36
Figure 3-6: PCIe Mini Slot Location	37
Figure 3-7: PCIe Mini Card Installation.....	37
Figure 3-8: mSATA Card Thermal Pad	38
Figure 3-9: AF-12A-N26 HDD Bracket Retention Screws	39
Figure 3-10: AF-12A-N26 HDD Retention Screws.....	40
Figure 3-11: AF-12A-N26 HDD Installation.....	40
Figure 3-12: AT/ATX Switch Location.....	41
Figure 3-13: Clear CMOS Jumper	45
Figure 3-14: COM3 Pin 9 Setting Jumper Location.....	46
Figure 3-15: RS-232/422/485 Serial Port Select Jumper Location	47
Figure 3-16: Wall-mounting Bracket.....	49
Figure 3-17: Chassis Support Screws.....	50
Figure 3-18: Secure the Panel PC	51
Figure 3-19: AFL-W07A-N26 Panel Opening.....	52
Figure 3-20: AFL-08A-N26 Panel Opening	52

AFL-xxA-N26 Series Panel PC

Figure 3-21: AFL-10A-N26 Panel Opening	52
Figure 3-22: AFL-12A-N26 Panel Opening	53
Figure 3-23: Tighten the Panel Mounting Clamp Screws	53
Figure 3-24: AFL-W07A-N26/AFL-08A-N26 Arm Mounting Retention Screw Holes.....	54
Figure 3-25: AFL-10A-N26/AFL-12A-N26 Arm Mounting Retention Screw Holes	55
Figure 3-26: The Rack/Cabinet Bracket.....	56
Figure 3-27: Secure the Rack/Cabinet Bracket (AFL-10A-N26/AFL-12A-N26).....	56
Figure 3-28: Install into a Rack/Cabinet	57
Figure 3-29: LAN Connection	58
Figure 3-30: Serial Device Connector.....	59
Figure 3-31: Serial Device Connector.....	60
Figure 3-32: USB Device Connection	61
Figure 4-1: AFL-10A-N26 SO-DIMM Socket Location.....	65
Figure 4-2: SO-DIMM Module Installation.....	65
Figure 4-3: Removing the Antennas	66
Figure 4-4: Releasing the WLAN Card.....	66
Figure 6-1: Drivers	98
Figure 6-2: Chipset Driver Screen.....	99
Figure 6-3: Chipset Driver Welcome Screen.....	99
Figure 6-4: Chipset Driver License Agreement	100
Figure 6-5: Chipset Driver Read Me File	101
Figure 6-6: Chipset Driver Setup Operations	101
Figure 6-7: Chipset Driver Installation Finish Screen.....	102
Figure 6-8: VGA Driver Read Me File.....	103
Figure 6-9: VGA Driver Setup Files Extracted	103
Figure 6-10: VGA Driver Welcome Screen	104
Figure 6-11: VGA Driver License Agreement.....	105
Figure 6-12: VGA Driver Read Me File.....	105
Figure 6-13: VGA Driver Setup Operations	106
Figure 6-14: VGA Driver Installation Finish Screen	106
Figure 6-15: LAN Driver Welcome Screen	107
Figure 6-16: LAN Driver Welcome Screen	108
Figure 6-17: LAN Driver Installation	108
Figure 6-18: LAN Driver Installation Complete.....	109
Figure 6-19: The InstallShield Wizard Starts	109

Figure 6-20: Preparing Setup Screen	110
Figure 6-21: InstallShield Wizard Welcome Screen	110
Figure 6-22: Audio Driver Software Configuration.....	111
Figure 6-23: Restart the Computer	111
Figure 6-24: Welcome Screen	112
Figure 6-25: License Agreement	113
Figure 6-26: Ready to Install the Program	113
Figure 6-27: Installing PenMount DMC9000.....	114
Figure 6-28: Reboot the Computer	114
Figure 6-29: Wireless Driver License Agreement.....	115
Figure 6-30: Wireless Driver Configuration Tool Options	116
Figure 6-31: Wireless Mode Select Window	116
Figure 6-32: Wireless Driver Installation	117
Figure 7-1: Main Board Layout Diagram (Front Side).....	119
Figure 7-2: Main Board Layout Diagram (Solder Side).....	120

List of Tables

Table 1-1: Model Variations	17
Table 1-2: AFL-xxA-N26 Series System Specifications	26
Table 3-1: Jumpers	43
Table 3-2: Preconfigured Jumpers	43
Table 3-3: Clear CMOS Jumper Settings.....	44
Table 3-4: COM3 Pin 9 Setting Jumper Settings	45
Table 3-5: RS-232/422/485 Serial Port Select Jumper Settings	46
Table 3-6: RS-422 Pinouts	47
Table 3-7: RS-485 Pinouts	47
Table 5-1: BIOS Navigation Keys	70
Table 7-1: Peripheral Interface Connectors	121
Table 7-2: Audio Line-out Connector (CN3) Pinouts	122
Table 7-3: Audio MIC-in Connector (MIC1) Pinouts	122
Table 7-4: Audio DMIC-in Connector (DMIC1) Pinouts	122
Table 7-5: Battery Connector (CN1) Pinouts	123
Table 7-6: COM2 Connector Pinouts	123
Table 7-7: CPU Fan Connector (CPU_FAN1) Pinouts.....	123
Table 7-8: DIO Connector (DIO1) Pinouts	123
Table 7-9: HDD LED Connector (HDD_CN1) Pinouts	124
Table 7-10: I2C Connector (CN4) Pinouts	124
Table 7-11: LVDS Connector (LVDS1) Pinouts.....	124
Table 7-12: LVDS Backlight Connector (INVERTER1) Pinouts.....	125
Table 7-13: MCU Connector (JP8) Pinouts	125
Table 7-14: MCU Connector (HOTKEY_CN1) Pinouts.....	125
Table 7-15: PCIe Mini Card Slot (M_PCIE1) Pinouts	126
Table 7-16: PCIe Mini Card Slot (M_PCIE2) Pinouts	127
Table 7-17: Power LED Connector (PW_LED1) Pinouts.....	128
Table 7-18: Power Button Connector (PW_BTN1) Pinouts	128
Table 7-19: SATA Power Connector (SATA_PWR1) Pinouts	128
Table 7-20: SATA Connector (SATA1) Pinouts	128
Table 7-21: Touch Panel Connector (TS1) Pinouts.....	129

Table 7-22: TTL Panel Connector (CN6) Pinouts.....	130
Table 7-23: USB Connector (USB1) Pinouts.....	130
Table 7-24: USB Connector (USB2) Pinouts.....	130
Table 7-25: USB Connector (USB3) Pinouts.....	131
Table 7-26: USB2 and USB3 Power Connector (JP18) Pinouts	131
Table 7-27: Rear Panel Connectors	131
Table 7-28: Audio Line-in Connector (AUX1) Pinouts	132
Table 7-29: Ethernet Connector (LAN1, LAN2) Pinouts.....	132
Table 7-30: Power Connector (CN5) Pinouts.....	132
Table 7-31: RS-232 Serial Port (COM1) Pinouts	133
Table 7-32: RS-232 Serial Port (COM3, DB-9) Pinouts	133
Table 7-33: RS-422 Serial Port (COM4, DB-9) Pinouts.....	133
Table 7-34: RS-485 Serial Port (COM4, DB-9) Pinouts.....	133
Table 7-35: Reset Button Connector (RST1) Pinouts	134
Table 7-36: USB 2.0 Connectors (USB4) Pinouts.....	134
Table 7-37: VGA Connector (VGA1) Pinouts	134
Table 7-38: Preconfigured Jumpers	135
Table 7-39: Backlight Voltage Selection Jumper (J_BL1) Settings.....	135
Table 7-40: Inverter ADJ Power Selection Jumper (JP6) Settings	135
Table 7-41: Inverter Power Selection Jumper (JP1) Settings	135
Table 7-42: LVDS Voltage Selection Jumper (J_VLVDS1) Settings	136
Table 7-43: Touchscreen Selection Jumper (J1) Settings	136

Chapter

1

Introduction

1.1 Overview



Figure 1-1: AFOLUX AFL-xxA-N26 Flat Panel PC

The AFL-xxA-N26 series is Intel® Atom™ N2600 powered flat panel PCs with a rich variety of functions and peripherals. All AFL-xxA-N26 models are designed for easy and simplified integration in to kiosk and point-of-sales (POS) applications.

The Intel® NM10 Express Chipset ensures optimal memory, graphics, and peripheral I/O support. The system comes with 2.0 GB of preinstalled DDR3 SDRAM ensuring smooth data throughputs with reduced bottlenecks and fast system access.

Two serial ports and two external USB 2.0 ports ensure simplified connectivity to a variety of external peripheral devices. Wi-Fi capabilities and two RJ-45 Ethernet connectors ensure smooth connection of the system to an external LAN.

1.1.1 Features and Model Variations

There are four models in the AFL-xxA-N26 series. Both models feature the following:

- Intel® Atom™ dual-core processor N2600 (1M Cache, 1.6 GHz)
- Intel® NM10 Express Chipset
- 2 GB 1333 MHz/1066 MHz DDR3 SDRAM preinstalled
- 802.11 b/g/n 2T2R wireless module
- Two RJ-45 GbE connectors

AFL-xxA-N26 Series Panel PC

- Two USB 2.0 ports
- Watchdog timer that triggers a system reset if the system hangs for some reason
- Supports secondary display through VGA connection
- 9 V ~ 28 V wide range DC power input
- mSATA SSD supported
- IP 64 compliant front panel
- AT or ATX power mode
- Touch screen
- RoHS compliance

There are four kinds of panel size of the AFL-xxA-N26 series. The model numbers and model variations are listed below.

Model	Size	Brightness	Resolution
AFL-W07A-N26/R/2G	Wide 7"	500 cd/m ²	800 x 480
AFL-08A-N26/R/2G	8.4"	450 cd/m ²	800 x 600
AFL-10A-N26/R/2G	10.4"	400 cd/m ²	800 x 600
AFL-12A-N26/R/2G	12.1"	500 cd/m ²	1024 x 768

Table 1-1: Model Variations

1.1.2 Applications

The AFL-xxA-N26 panel PCs are elegant yet sophisticated systems that are easily implemented in commercial environments, industrial environments and corporate environments.

1.2 External Overview

The stylish AFL-xxA-N26 panel PC comprises of a screen, rear panel, top panel, bottom panel and two side panels (left and right). An ABS/PC plastic front frame surrounds the front screen. The rear panel provides screw holes for a wall-mounting bracket compliant with VESA FDMI standard. An I/O interface panel on the bottom panel of the AFL-xxA-N26

provides access to external interface connectors that include LAN, USB 2.0, serial port, reset button, power connector and power switch.

1.2.1 Front Panel

The front side of the AFOLUX AFL-xxA-N26 series is a flat panel TFT LCD screen with LED backlight surrounded by an ABS/PC plastic frame. The top of the front panel has a power LED.

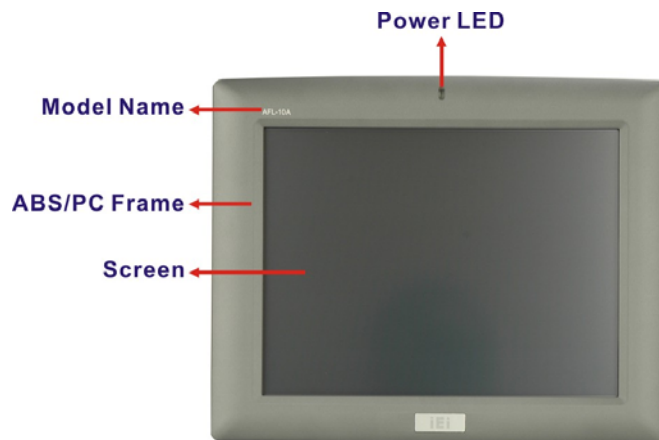

Figure 1-2: AFL-xxA-N26 Front View

1.2.2 Rear Panel

The rear panel provides access to retention screw holes that support VESA mounting. Refer to **Figure 1-3**.

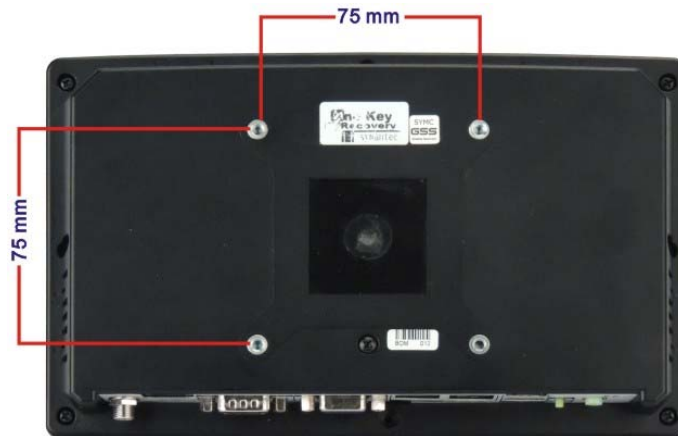

Figure 1-3: AFL-xxA-N26 Rear View

AFL-xxA-N26 Series Panel PC

1.2.3 I/O Interface Panel

The I/O interface panel located on the bottom of the AFL-xxA-N26 has the following I/O interface connectors:

- 1 x Audio line-out connector
- 1 x 9 V ~ 28 V DC In connector
- 1 x RS-232 RJ-45 connector (COM1)
- 1 x RS-232/422/485 DB-9 connector
 - COM3: RS-232
 - COM4: RS-422/485
- 2 x GbE RJ-45 connectors
- 2 x USB 2.0 connectors (W07A, 08A, 10A models)
- 4 x USB 2.0 connectors (12A model)
- 1 x VGA connector
- 1 x Power button
- 1 x Reset button

The external I/O interface connector panel of the AFL-10A-N26 and AFL-12A-N26 are shown below.

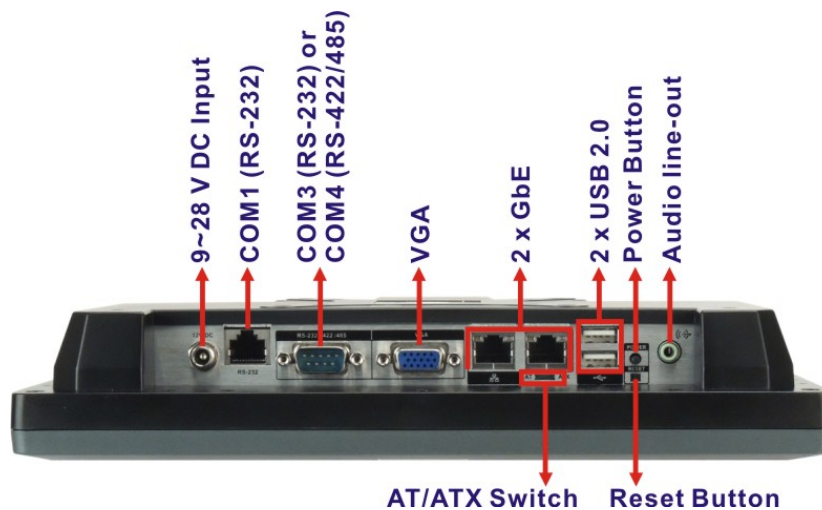

Figure 1-4: AFL-10A-N26 I/O Interface Connector Panel

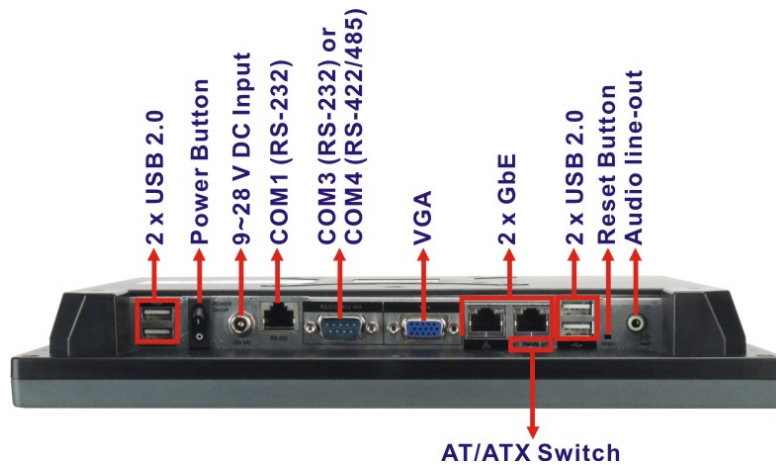

Figure 1-5: AFL-12A-N26 I/O Interface Connector Panel

1.2.4 Top Panel and Side Panels

The top panel and side panels of AFOLUX AFL-xxA-N26 series provide access to slots that support panel mount and rack mount (Figure 1-6).



Figure 1-6: AFL-xxA-N26 Top View



Figure 1-7: AFL-10A-N26 Side View

AFL-xxA-N26 Series Panel PC

1.3 Dimensions

The following sections provide detailed schematics and information on the dimensions of the AFL-xxA-N26 series.

1.3.1 AFL-W07A-N26 Dimensions

The AFL-W07A-N26 dimensions are shown in **Figure 1-8** and listed below.

- **Width:** 226.00 mm
- **Height:** 140.00 mm
- **Depth:** 40.2 mm

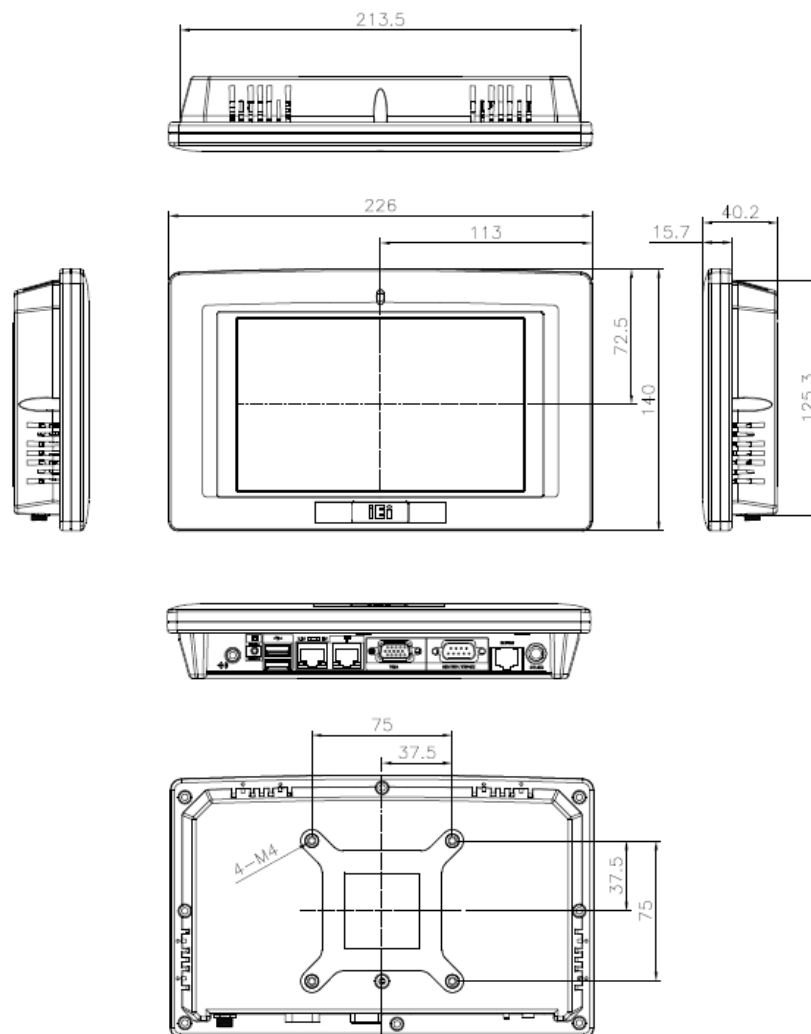

Figure 1-8: AFL-W07A-N26 Dimensions (mm)

1.3.2 AFL-08A-N26 Dimensions

The AFL-08A-N26 dimensions are shown in **Figure 1-9** and listed below.

- **Width:** 233.86 mm
- **Height:** 183.89 mm
- **Depth:** 41.05 mm

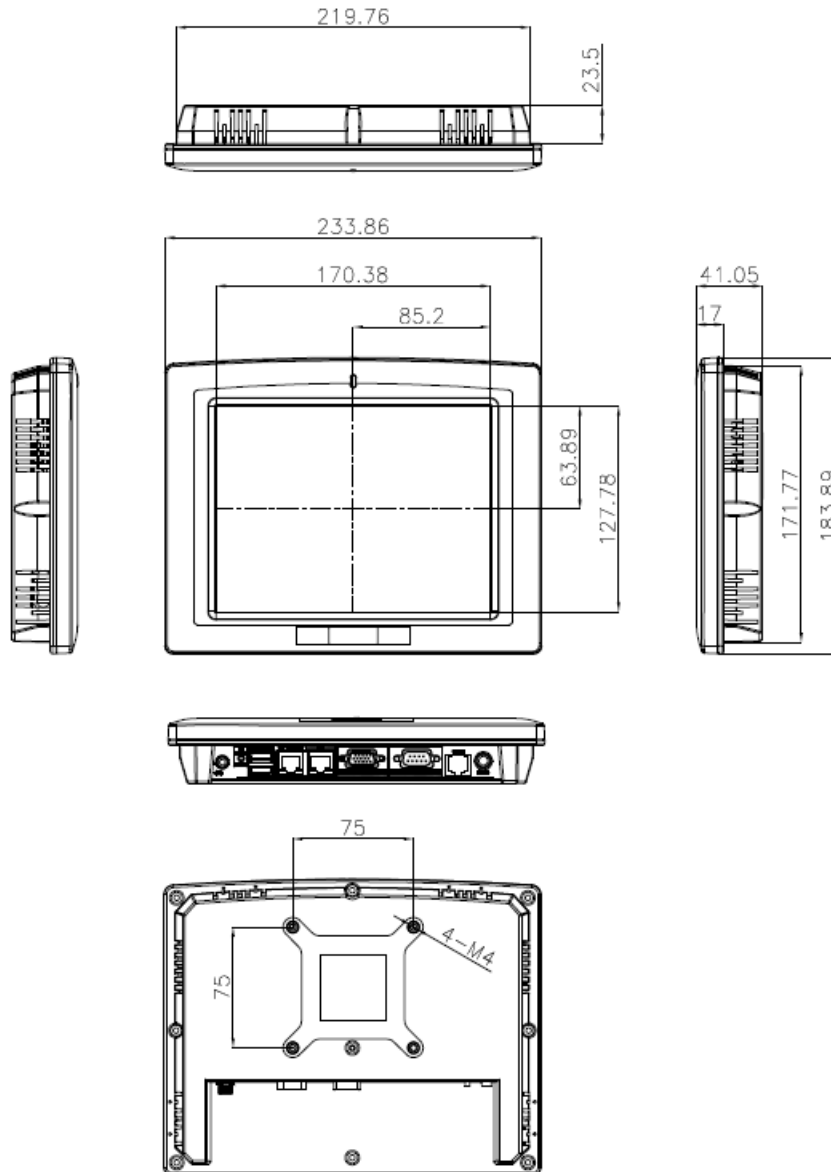

Figure 1-9: AFL-08A-N26 Dimensions (mm)

AFL-xxA-N26 Series Panel PC

1.3.3 AFL-10A-N26 Dimensions

The AFL-10A-N26 dimensions are shown in **Figure 1-10** and listed below.

- **Width:** 276.0 mm
- **Height:** 222.0 mm
- **Depth:** 51.50 mm

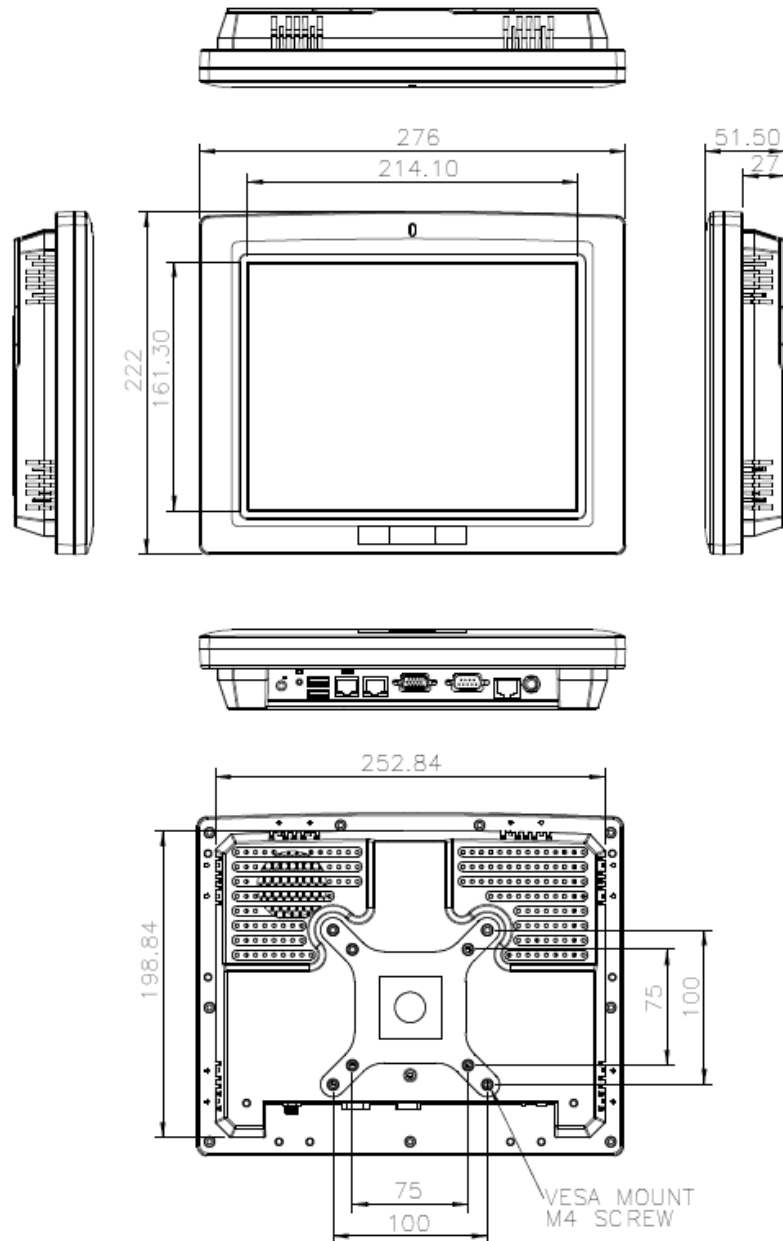

Figure 1-10: AFL-10A-N26 Dimensions (mm)

1.3.4 AFL-12A-N26 Dimensions

The AFL-12A-N26 dimensions are shown in **Figure 1-10** and listed below.

- **Width:** 304.0 mm
- **Height:** 246.0 mm
- **Depth:** 49.5 mm

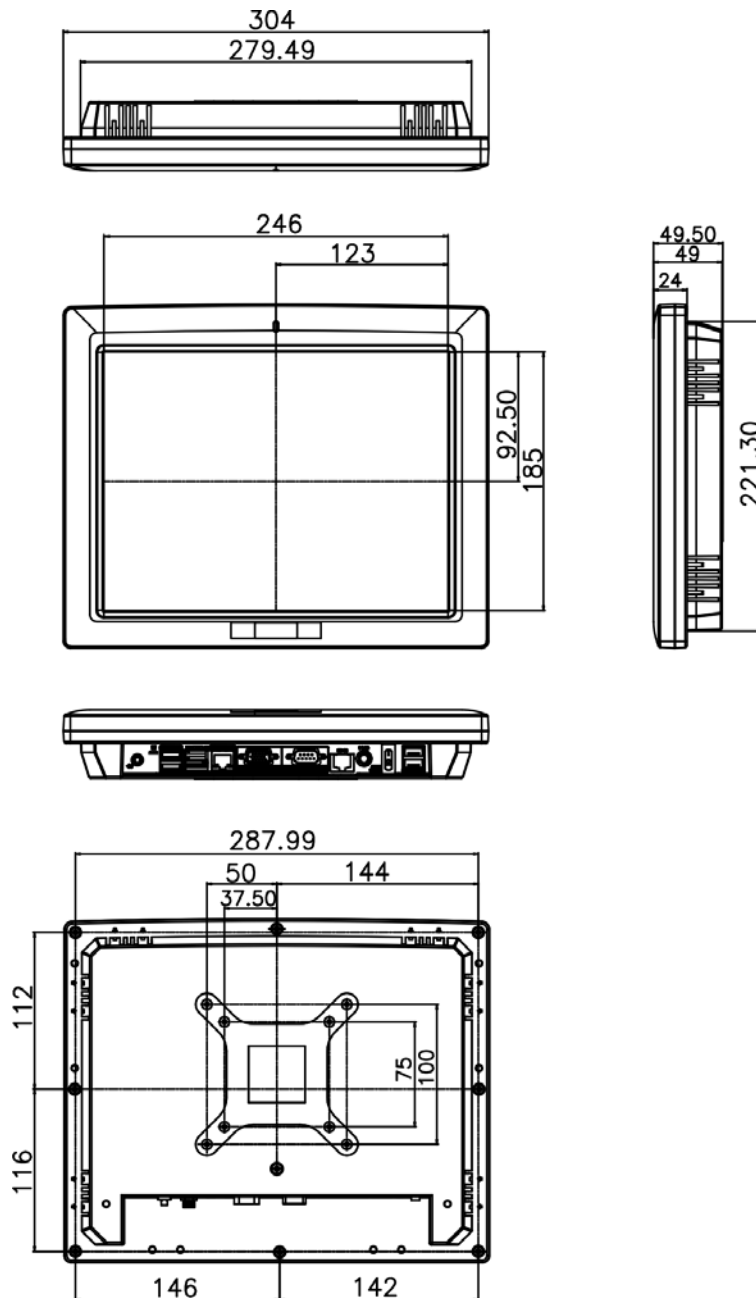

Figure 1-11: AFL-12A-N26 Dimensions (mm)

AFL-xxA-N26 Series Panel PC

1.4 Internal Overview

The AFOLUX AFL-xxA-N26 has the following components installed internally:

- 1 x Motherboard
- 1 x 2.0 GB 1333 MHz/1066 MHz DDR3 SDRAM SO-DIMM
- 1 x Wireless module

1.5 System Specifications

The technical specifications for the AFOLUX AFL-xxA-N26 series systems are listed in **Table 1-2.**

Specification	AFL-W07A-N26	AFL-08A-N26	AFL-10A-N26	AFL-12A-N26
LCD Size	Wide 7"	8.4"	10.4"	12.1"
Max. Resolution	800 x 480	800 x 600	800 x 600	1024 x 768
Contrast Ratio	400:1	600:1	700:1	700:1
Brightness (cd/m²)	500	450	400	500
LCD Color	262K	262K	262K	262K
Pixel Pitch (H x V) (mm)	0.0635 x 0.1905	0.213 x 0.213	0.264 x 0.264	0.3057 x 0.3057
Viewing Angle (H-V)	140 / 110	160 / 140	160 / 140	160 / 160
Backlight	LED backlight	LED backlight	LED backlight	LED backlight
Backlight MTBF	50,000 hrs	50,000 hrs	50,000 hrs	50,000 hrs
CPU	1.6 GHz Intel® Atom™ dual-core processor N2600			
Chipset	Intel® NM10 Express Chipset			
Memory	One 2.0 GB 1333 MHz/1066 MHz DDR3 SDRAM SO-DIMM pre-installed (system max. 2 GB)			
Ethernet Controller	Two Realtek RTL8111E PCIe GbE controllers with ASF 2.0 support			
Wireless	Wireless LAN 802.11 b/g/n 2T2R module (PCIe Mini card)			
Watchdog Timer	Software Programmable supports 1 sec. ~ 255 sec. system reset			
Audio	AMP 2 W + AMP 2 W (built-in stereo speakers)			
Storage	1 x PCIe Mini card slot for mSATA SSD 1 x 2.5" SATA HDD bay (AFL-12A-N26 only)			
Construction Material	ABS + PC plastic front frame			
Mounting	Panel, Wall, Rack, Stand, Arm VESA 75 mm x 75 mm or			

	VESA 100 mm x 100 mm (AFL-10A-N26 and AFL-12A-N26 only)			
Front Panel Color	Gray 7539U			
Dimensions (W x H x D) (mm)	226 x 140 x 41	234 x 184 x 42	276 x 222 x 51	304 x 246 x 50
Operation Temperature	-10°C ~ 50°C			
Storage Temperature	-20°C ~ 60°C			
Humidity	10% ~ 95% (non-condensing)			
Net weight	0.6 kg	0.8 kg	1.4 kg	1.8 kg
IP level (front panel)	IP 64			
Touch Screen	Resistive Type 4-wire (touch controller is on board)		Resistive Type 5-wire (touch controller is on board)	
Power Requirement	9 V ~ 28 V DC		9 V ~ 28 V DC	
Power Adapter	36 W		60 W	
	Input: 90 VAC ~ 264 VAC @ 50 Hz / 60 Hz			
	Output: 12 V DC			
I/O Ports and Switches	1 x 9 V ~ 28 V DC input jack			
	1 x Audio line-out connector			
	1 x RS-232 COM port connector (RJ-45)			
	1 x RS-232/422/485 COM port connector (DB-9)			
	2 x RJ-45 for LAN			
	2 x USB 2.0 ports (four USB 2.0 ports on the AFL-12A-N26 model)			
	1 x VGA connector			
	1 x Power button			
	1 x Reset button			
	1 x AT/ATX power switch			

Table 1-2: AFL-xxA-N26 Series System Specifications

Chapter

2

Unpacking

2.1 Unpacking

To unpack the flat panel PC, follow the steps below:



WARNING!



The front side LCD screen has a protective plastic cover stuck to the screen. Only remove the plastic cover after the flat panel PC has been properly installed. This ensures the screen is protected during the installation process.

- Step 1:** Use box cutters, a knife or a sharp pair of scissors that seals the top side of the external (second) box.
- Step 2:** Open the external (second) box.
- Step 3:** Use box cutters, a knife or a sharp pair of scissors that seals the top side of the internal (first) box.
- Step 4:** Lift the monitor out of the boxes.
- Step 5:** Remove both polystyrene ends, one from each side.
- Step 6:** Pull the plastic cover off the flat panel PC.
- Step 7:** Make sure all the components listed in the packing list are present.

AFL-xxA-N26 Series Panel PC





2.1.1 Packing List

The AFL-xxA-N26 flat panel PC is shipped with the following components:

Quantity	Item	Image
Standard		
1	AFOLUX AFL-xxA-N26 series	
1	Power adapter	
1	Power cord	
4	M3*4 flat-head screws	
1	Touch pen	
1	Thermal pad for mSATA SSD	
1	One Key Recovery CD	

1	User manual CD and driver CD	
Optional		
	Panel mounting kit (P/N: AFLPK-12)	
	Wall mounting kit (P/N: AFLWK-12)	
	Stand (P/N: STAND-A12)	
	Arm (P/N: ARM-11-RS)	
	Arm (P/N: ARM-31-RS)	
	LCD monitor stand with adjustable hinge (P/N: VSTAND-A07/A10/A12)	

AFL-xxA-N26 Series Panel PC

Hybrid Card Reader (P/N: AFLP-xxAMSI-U)	
Magnetic card reader (P/N: AFLP-xxAMSR-U)	
DC 9~36 V Input UPS (P/N: AUPS-A20-R10)	
DC 12 V Input UPS (P/N: AUPS-A10-R10)	

If any of these items are missing or damaged, contact the distributor or sales representative immediately.

Chapter

3

Installation

AFL-xxA-N26 Series Panel PC

3.1 Anti-static Precautions



WARNING:

Failure to take ESD precautions during the maintenance of the AFL-xxA-N26 may result in permanent damage to the AFL-xxA-N26 and severe injury to the user.

Electrostatic discharge (ESD) can cause serious damage to electronic components, including the AFL-xxA-N26. Dry climates are especially susceptible to ESD. It is therefore critical that whenever the AFL-xxA-N26 is accessed internally, or any other electrical component is handled, the following anti-static precautions are strictly adhered to.

- ***Wear an anti-static wristband:*** - Wearing a simple anti-static wristband can help to prevent ESD from damaging the board.
- ***Self-grounding:*** - Before handling the board touch any grounded conducting material. During the time the board is handled, frequently touch any conducting materials that are connected to the ground.
- ***Use an anti-static pad:*** - When configuring the AFL-xxA-N26, place it on an anti-static pad. This reduces the possibility of ESD damaging the AFL-xxA-N26.
- ***Only handle the edges of the PCB:*** - When handling the PCB, hold the PCB by the edges.

3.2 Installation Precautions

When installing the flat panel PC, please follow the precautions listed below:

- **Power turned off:** When installing the flat panel PC, make sure the power is off. Failing to turn off the power may cause severe injury to the body and/or damage to the system.
- **Certified Engineers:** Only certified engineers should install and modify onboard functionalities.

- **Anti-static Discharge:** If a user open the rear panel of the flat panel PC, to configure the jumpers or plug in added peripheral devices, ground themselves first and wear an anti-static wristband.

3.3 Installation and Configuration Steps

The following installation steps must be followed.

Step 1: Unpack the flat panel PC

Step 2: Install a mSATA SSD card

Step 3: Install a HDD (AFL-12A-N26 only)

Step 4: Configure the system

Step 5: Connect peripheral devices to the bottom panel of the flat panel PC

Step 6: Mount the flat panel PC

3.4 Opening the System



WARNING:

Over-tightening back cover screws will crack the plastic frame.
Maximum torque for cover screws is 5 kg-cm (0.36 lb-ft/0.49 Nm).

To access the AFL-xxA-N26 internally the back cover and the internal aluminum cover must be removed. To remove the covers, please follow the steps below.

- Step 1:** Remove the retention screws (**Figure 3-1**) and lift the back cover off the flat panel PC.

AFL-xxA-N26 Series Panel PC



Figure 3-1: Back Cover Retention Screws

Step 2: Remove the retention screws securing the internal aluminum cover. The screw numbers are varied in different models. The following figures show the aluminum cover retention screws of each model.

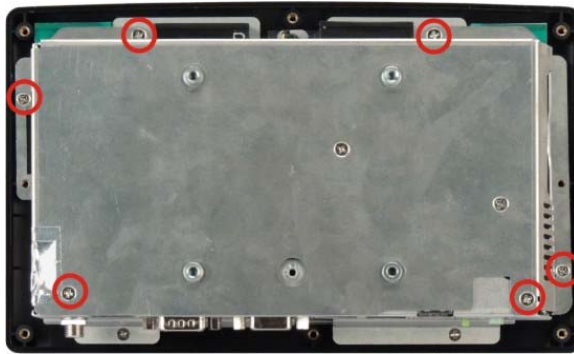

Figure 3-2: AFL-W07A-N26 Aluminum Back Cover Retention Screws

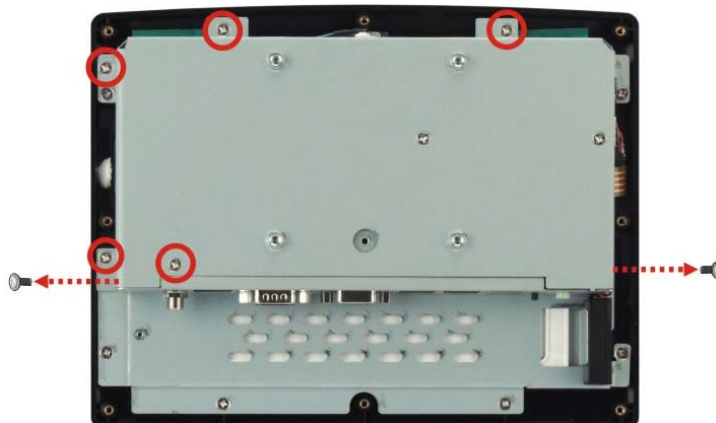

Figure 3-3: AFL-08A-N26 Aluminum Back Cover Retention Screws

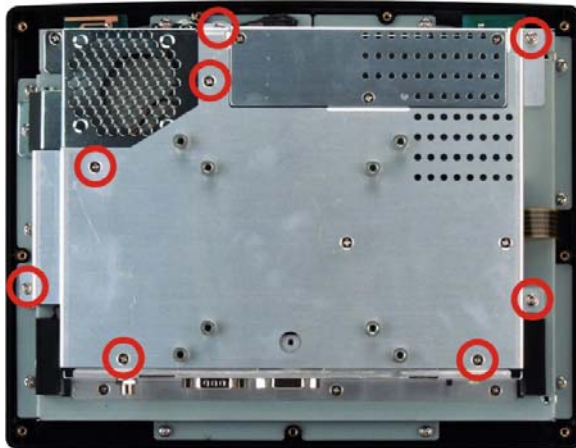

Figure 3-4: AFL-10A-N26 Aluminum Back Cover Retention Screws

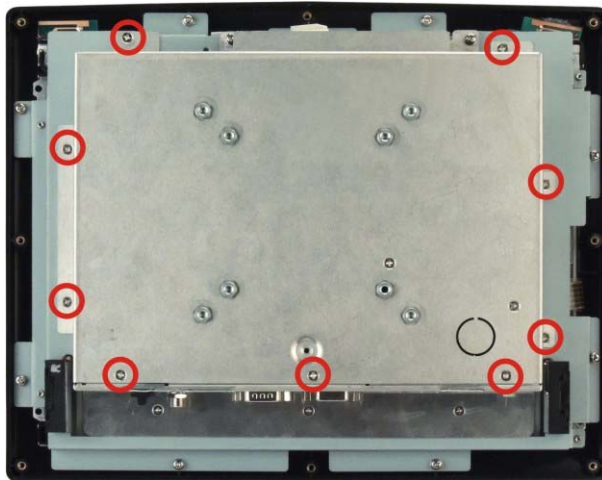

Figure 3-5: AFL-12A-N26 Aluminum Back Cover Retention Screws

Step 3: Lift the aluminum cover off the AFL-xxA-N26 series.

3.5 mSATA SSD Installation

The AFL-xxA-N26 series has one PCIe Mini slot inside the rear panel for mSATA SSD installation. To install the mSATA SSD, follow the instructions below.

Step 1: Open the system by following the instruction described in **Section 3.4**.

Step 2: Locate the PCIe Mini slot (**Figure 3-6**).

AFL-xxA-N26 Series Panel PC



Figure 3-6: PCIe Mini Slot Location

Step 3: Insert into the socket at an angle. Line up the notch on the card with the notch on the connector. Slide the PCIe Mini card into the socket at an angle of about 20°.

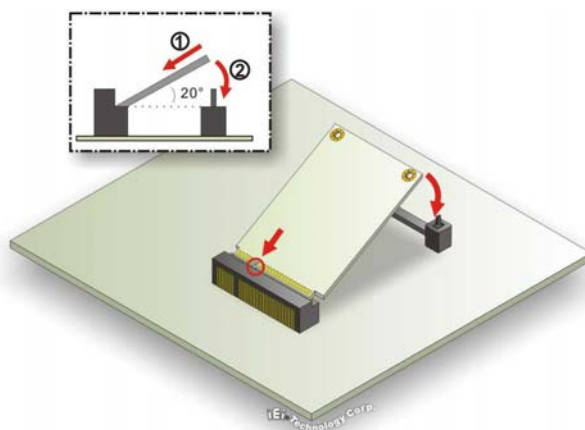

Figure 3-7: PCIe Mini Card Installation

Step 4: Push down until the card clips into place. Push the other end of the card down until it clips into place on the plastic connector.

Step 5: Attach the thermal pad onto the mSATA card. Use the thermal pad come with the AFL-xxA-N26 to attach onto the controller chips of the mSATA card (Figure 3-8). If there is a label sticker on the mSATA card, remove the sticker first.

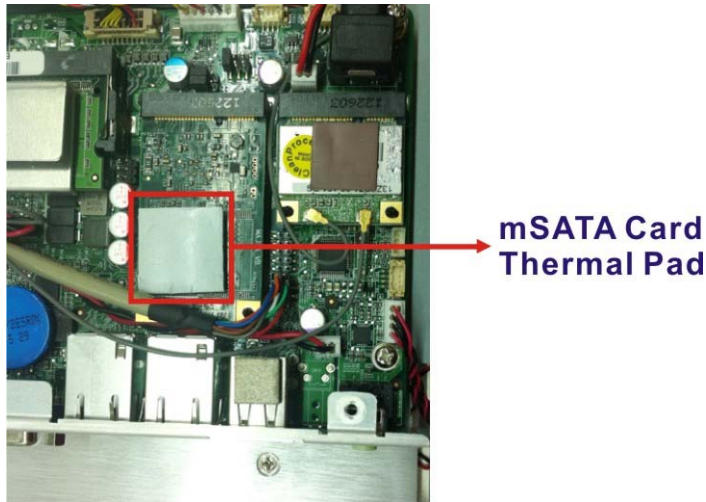

Figure 3-8: mSATA Card Thermal Pad

Step 6: Replace the internal aluminum cover and the plastic back cover.



WARNING:

The mSATA card thermal pad helps draw the heat away from the mSATA components and evenly dissipates it into the heat sink on the internal aluminum cover. Failing to apply the thermal pad properly may cause SSD and system damage.

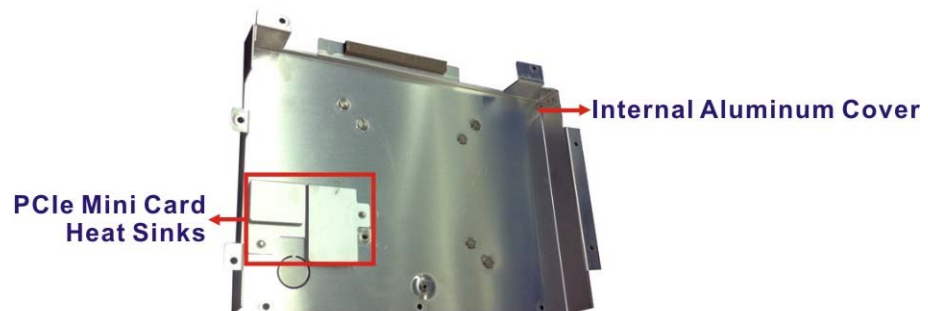

AFL-xxA-N26 Series Panel PC

3.6 HDD Installation (AF-12A-N26 Only)

To install the HDD into the AF-12A-N26, please follow the steps below:

- Step 1:** Open the system by following the instruction described in **Section 3.4**.
- Step 2:** Remove the four HDD bracket retention screws (**Figure 3-9**). Disconnect the SATA cable and the SATA power cable. Lift the HDD bracket off the panel PC.

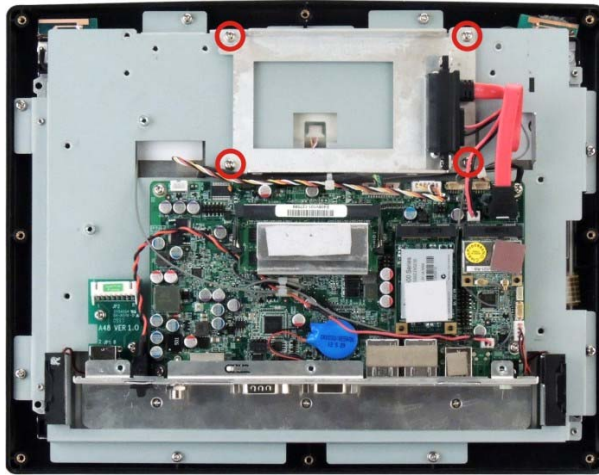

Figure 3-9: AF-12A-N26 HDD Bracket Retention Screws

- Step 3:** Attach the HDD brackets to the HDD. To do this, align the four retention screw holes in the both sides of the HDD bracket with the retention screw holes on the sides of the HDD. Insert four retention screws into the HDD bracket (**Figure 3-10**). In the mean time, make sure the rear of the HDD is connected to the SATA cable on the HDD bracket.



Figure 3-10: AF-12A-N26 HDD Retention Screws

Step 4: Install the HDD into the AF-12A-N26 by aligning the retention screw holes in the HDD brackets with the retention screw holes on the chassis. Insert the four retention screws.

Step 5: Connect the SATA cable and the SATA power cable to the connectors on the motherboard.

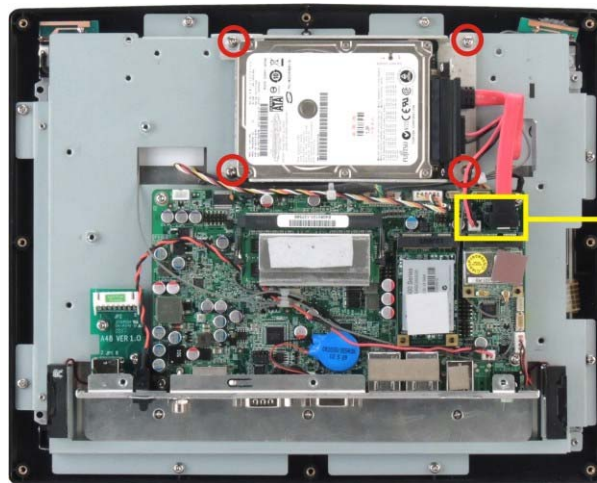

SATA Cable and
SATA Power Cable
Connection

Figure 3-11: AF-12A-N26 HDD Installation

Step 6: Replace the aluminum back cover to the chassis.

Step 7: Replace the plastic back cover.

AFL-xxA-N26 Series Panel PC



WARNING:

Over-tightening back cover screws will crack the plastic frame.
Maximum torque for cover screws is 5 kg-cm (0.36 lb-ft/0.49 Nm).

3.7 AT/ATX Mode Selection

AT and ATX power modes can both be used on the AFL-xxA-N26 series. The selection is made through an AT/ATX switch on the bottom panel (Figure 3-12). To select AT mode or ATX mode, follow the steps below.

Step 1: Locate the AT/ATX switch on the bottom panel (Figure 3-12).



Figure 3-12: AT/ATX Switch Location

Step 2: Adjust the AT/ATX switch.

3.7.1 AT Power Mode

With the AT mode selected, the power is controlled by a central power unit rather than a power switch. The AFL-xxA-N26 panel PC turns on automatically when the power is connected. The AT mode benefits a production line to control multiple panel PCs from a central management center and other applications including:

- ATM
- Self-service kiosk
- Plant environment monitoring system
- Factory automation platform

- Manufacturing shop flow

3.7.2 ATX Power Mode

With the ATX mode selected, the AFL-xxA-N26 panel PC goes in a standby mode when it is turned off. The panel PC can be easily turned on via network or a power switch in standby mode. Remote power control is perfect for advertising applications since the broadcasting time for each panel PC can be set individually and controlled remotely. Other possible application includes

- Security surveillance
- Point-of-Sale (POS)
- Advertising terminal

3.8 Jumper Settings



NOTE:

A jumper is a metal bridge used to close an electrical circuit. It consists of two or three metal pins and a small metal clip (often protected by a plastic cover) that slides over the pins to connect them. To CLOSE/SHORT a jumper means connecting the pins of the jumper with the plastic clip and to OPEN a jumper means removing the plastic clip from a jumper.

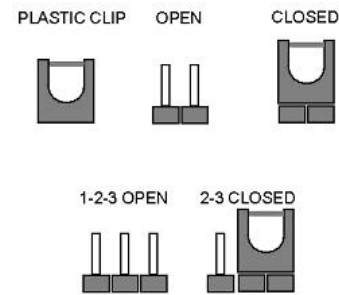

The following jumpers can be found on the motherboard installed in the AFL-xxA-N26. Before the AFL-xxA-N26 is installed, the jumpers must be set in accordance with the desired configuration. The jumpers on the AFL-xxA-N26 motherboard are listed in **Table 3-1**.

AFL-xxA-N26 Series Panel PC

Description	Label	Type
Clear CMOS	JP2	3-pin header
COM3 Pin 9 setting	JP5	6-pin header
RS-232/422/485 select	JP4	12-pin header

Table 3-1: Jumpers

3.8.1 Access the Jumpers

To access the jumpers, remove the back cover and the aluminum cover. To remove the covers, please refer to **Section 3.4**.

3.8.2 Preconfigured Jumpers



WARNING:

Do not change the settings on the jumpers in described here. Doing so may disable or damage the system.

The following jumpers are preconfigured for the AFL-xxA-N26. Users should no change these jumpers (**Table 3-2**). The jumper settings of the preconfigured jumpers are listed in Chapter 7 for reference.

Jumper Name	Label	Type
Backlight voltage selection	J_BL1	3-pin header
Inverter ADJ power selection	JP6	3-pin header
Inverter power selection	JP1	6-pin header
LVDS voltage selection	J_VLVDS1	3-pin header
Touchscreen selection	J1	4-pin header

Table 3-2: Preconfigured Jumpers

3.8.3 Clear CMOS Jumper

Jumper Label:	JP2
Jumper Type:	3-pin header
Jumper Settings:	See Table 3-3
Jumper Location:	See Figure 3-13

If the AFL-xxA-N26 fails to boot due to improper BIOS settings, the clear CMOS jumper clears the CMOS data and resets the system BIOS information. To do this, use the jumper cap to close the pins for a few seconds then remove the jumper clip.

If the “CMOS Settings Wrong” message is displayed during the boot up process, the fault may be corrected by pressing the F1 to enter the CMOS Setup menu. Do one of the following:

- Enter the correct CMOS setting
- Load Optimal Defaults
- Load Failsafe Defaults.

After having done one of the above, save the changes and exit the CMOS Setup menu.

The clear CMOS jumper settings are shown in **Table 3-3**.

Clear CMOS	Description	
Short 1 - 2	Keep CMOS Setup	Default
Short 2 - 3	Clear CMOS Setup	

Table 3-3: Clear CMOS Jumper Settings

The location of the clear CMOS jumper is shown in **Figure 3-13** below.

AFL-xxA-N26 Series Panel PC

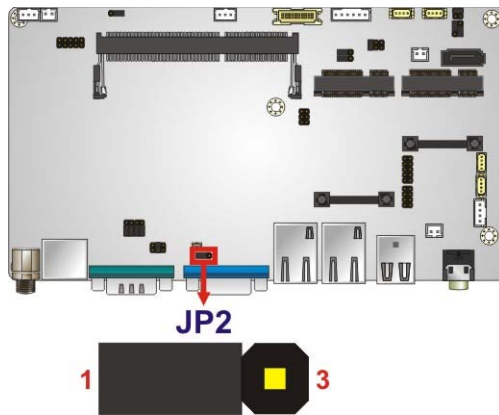

Figure 3-13: Clear CMOS Jumper

3.8.4 COM3 Port Pin 9 Select

Jumper Label:	JP5
Jumper Type:	6-pin header
Jumper Settings:	See Table 3-4
Jumper Location:	See Figure 3-14

This jumper configures pin 9 on COM3 DB-9 connector. Pin 9 on the COM3 DB-9 connector can be set as the ring (RI) signal, +5 V or +12 V. The COM3 Pin 9 Setting jumper selection options are shown in **Table 3-4**.

JP5	Description	
Short 1-2	COM1 RI Pin use +12 V	
Short 3-4	COM1 RI Pin use RI	Default
Short 5-6	COM1 RI Pin use +5 V	

Table 3-4: COM3 Pin 9 Setting Jumper Settings

The COM3 Pin 9 Setting jumper location is shown in **Figure 3-14** below.

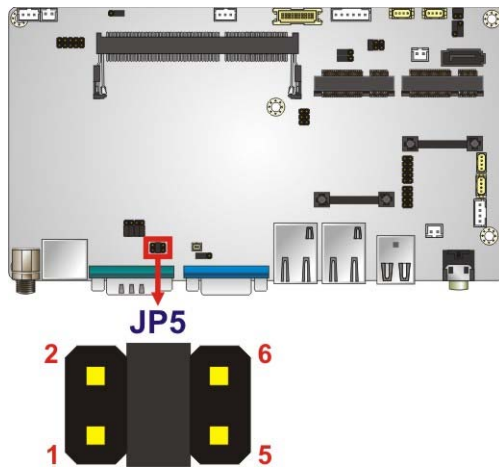

Figure 3-14: COM3 Pin 9 Setting Jumper Location

3.8.5 RS-232/422/485 Serial Port Select Jumper

- Jumper Label:** JP4
- Jumper Type:** 12-pin header (four 3-pin headers combined)
- Jumper Settings:** See Table 3-5
- Jumper Location:** See Figure 3-15

The RS-232/422/485 Serial Port Select jumper sets the communication protocol used by the DB-9 serial communications port as RS-232, RS-422 or RS-485. The RS-232/422/485 Serial Port Select settings are shown in Table 3-5.

RS-232/422/485 Select	Description	
Short 1-2, 4-5, 7-8, 10-11	COM3 RS-232	Default
Short 2-3, 5-6, 8-9, 11-12	COM4 RS-422/485	

Table 3-5: RS-232/422/485 Serial Port Select Jumper Settings

The RS-232/422/485 Serial Port Select jumper location is shown in Figure 3-15.

AFL-xxA-N26 Series Panel PC

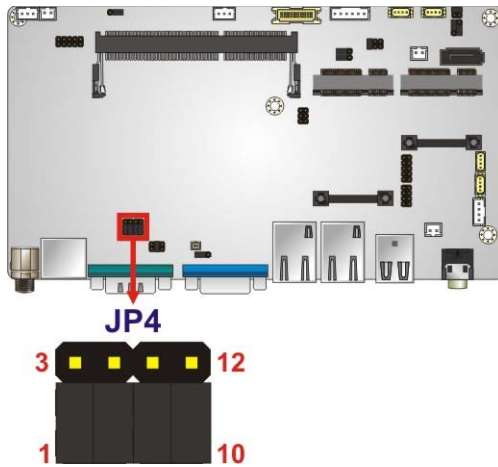

Figure 3-15: RS-232/422/485 Serial Port Select Jumper Location

3.8.5.1 COM4 RS-422 and RS-485 Pinouts

The pinouts for RS-422 and RS-485 operation of external serial port COM 4 are detailed below.

COM 4	RS-422 Description	
Pin 1	TX-	
Pin 2	TX+	
Pin 6	RX-	
Pin 7	RX+	

Table 3-6: RS-422 Pinouts

COM 4	RS-485 Description	
Pin 1	Data-	
Pin 2	Data+	

Table 3-7: RS-485 Pinouts

3.9 Mounting the System



WARNING!

When mounting the flat panel PC onto an arm, onto the wall or onto a panel, it is better to have more than one person to help with the installation to make sure the panel PC does not fall down and get damaged.

The four methods of mounting the AFOLUX AFL-xxA-N26 are listed below.

- Wall mounting
- Panel mounting
- Arm mounting
- Rack mounting

The four mounting methods are described below.

3.9.1 Wall Mounting

To mount the flat panel PC onto the wall, please follow the steps below.

- Step 1:** Select the location on the wall for the wall-mounting bracket.
- Step 2:** Carefully mark the locations of the four screw holes in the bracket on the wall.
- Step 3:** Drill four pilot holes at the marked locations on the wall for the bracket retention screws.
- Step 4:** Align the wall-mounting bracket screw holes with the pilot holes.
- Step 5:** Secure the mounting-bracket to the wall by inserting the retention screws into the four pilot holes and tightening them (**Figure 3-16**).

AFL-xxA-N26 Series Panel PC

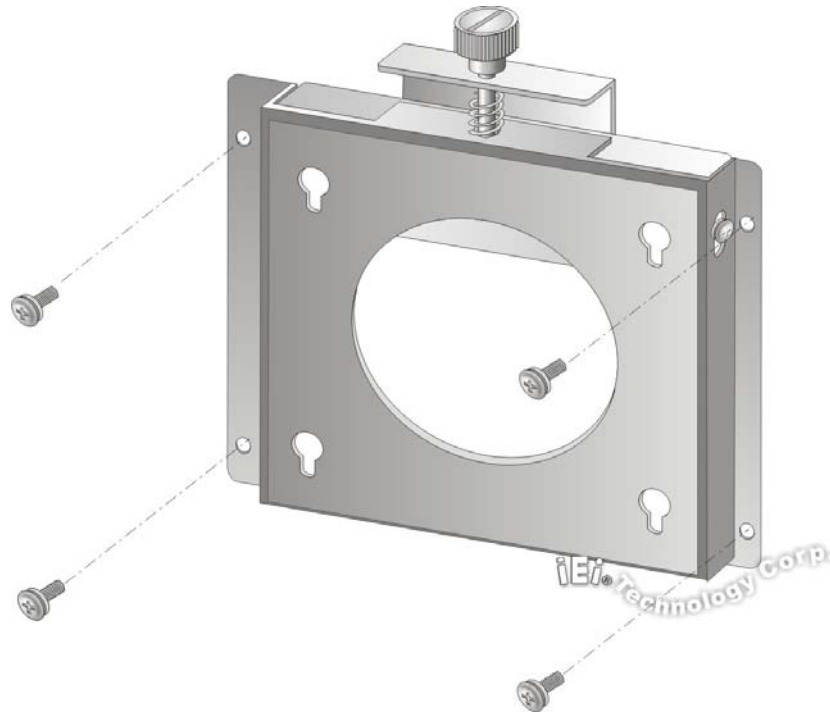

Figure 3-16: Wall-mounting Bracket

Step 6: Insert the four monitor mounting screws provided in the wall mount kit into the four screw holes on the rear panel of the flat panel PC and tighten until the screw shank is secured against the rear panel (**Figure 3-17**).



WARNING:

Please use the M4 screws provided in the wall mount kit for the rear panel. If the screw is missing, the thread depth of the replacement screw should be not more than 4 mm.

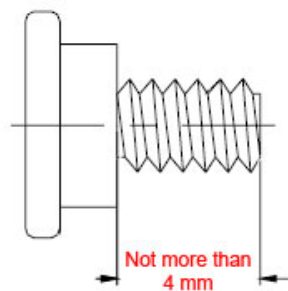

Step 7: Align the mounting screws on the monitor rear panel with the mounting holes on the bracket.

Step 8: Carefully insert the screws through the holes and gently pull the monitor downwards until the monitor rests securely in the slotted holes (**Figure 3-17**). Ensure that all four of the mounting screws fit snugly into their respective slotted holes.

**NOTE:**

In the diagram below the bracket is already installed on the wall.

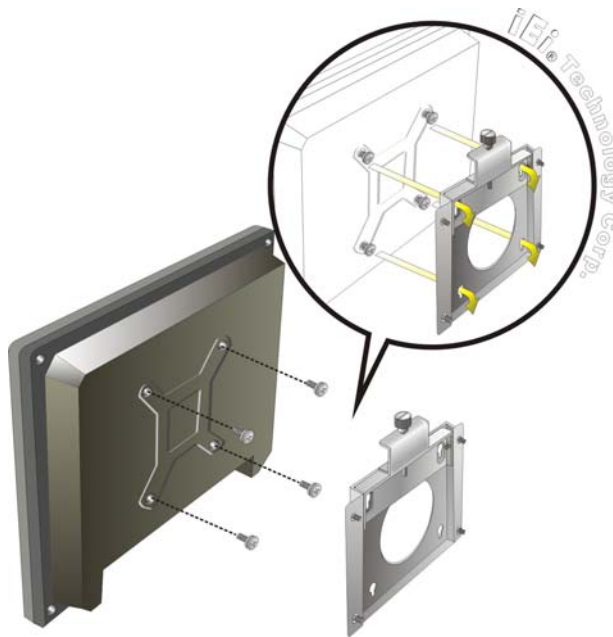

Figure 3-17: Chassis Support Screws

Step 9: Secure the panel PC by fastening the retention screw of the wall-mounting bracket. (**Figure 3-18**).

AFL-xxA-N26 Series Panel PC

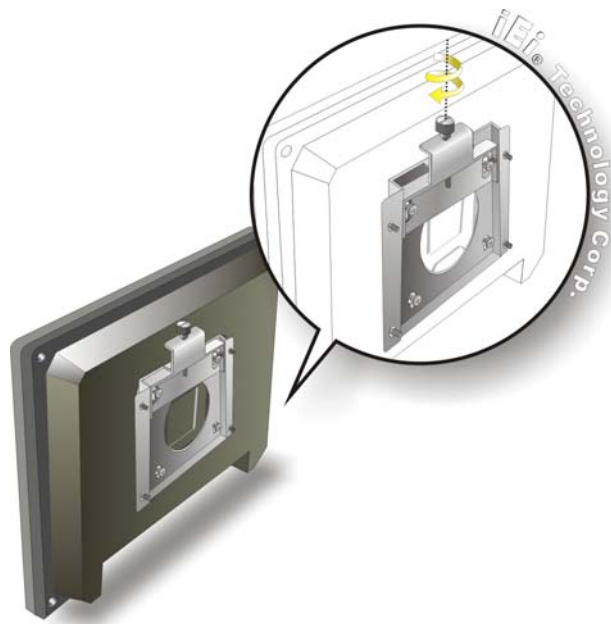

Figure 3-18: Secure the Panel PC

3.9.2 Panel Mounting

To mount the AFOLUX AFL-xxA-N26 series flat panel PC into a panel, please follow the steps below.

- Step 1:** Select the position on the panel to mount the flat panel PC.
- Step 2:** Cut out a section from the panel that corresponds to the rear panel dimensions of the flat panel PC. Take care that the panel section that is cut out is smaller than the overall size of the frame that surrounds the flat panel PC but just large enough for the rear panel of the flat panel PC to fit through (see **Figure 3-19**, **Figure 3-20**, **Figure 3-21** and **Figure 3-22**).

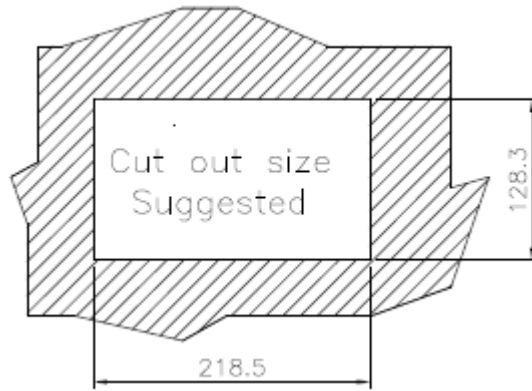

Figure 3-19: AFL-W07A-N26 Panel Opening

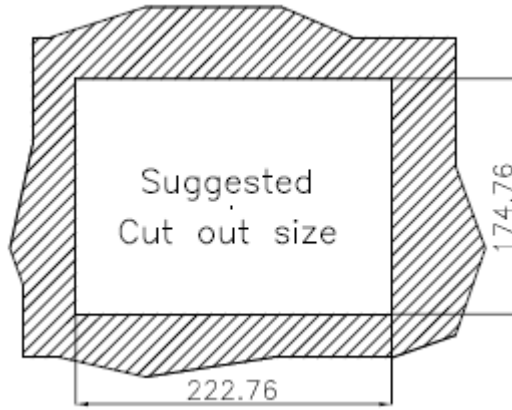

Figure 3-20: AFL-08A-N26 Panel Opening

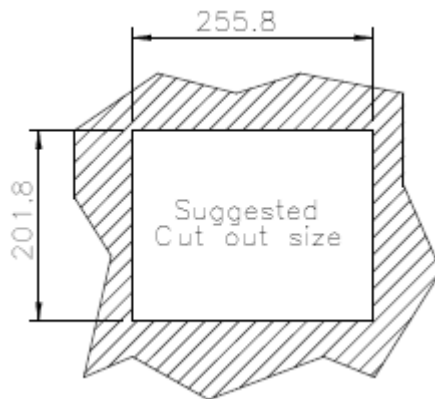

Figure 3-21: AFL-10A-N26 Panel Opening

AFL-xxA-N26 Series Panel PC

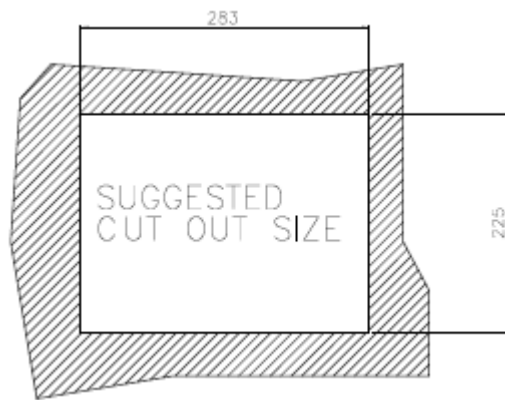

Figure 3-22: AFL-12A-N26 Panel Opening

- Step 3:** Slide the flat panel PC through the hole until the frame is flush against the panel.
- Step 4:** Insert the panel mounting clamps into the pre-formed holes along the edges of the chassis, behind the frame.
- Step 5:** Tighten the screws that pass through the panel mounting clamps until the plastic caps at the front of all the screws are firmly secured to the panel (**Figure 3-23**).

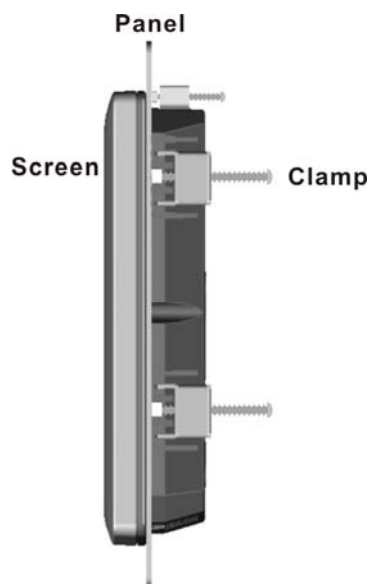

Figure 3-23: Tighten the Panel Mounting Clamp Screws

3.9.3 Arm Mounting

The AFL-xxA-N26 series is VESA (Video Electronics Standards Association) compliant and can be mounted on an arm with a 75mm interface pad. To mount the AFL-xxA-N26 series on an arm, please follow the steps below.

Step 1: The arm is a separately purchased item. Please correctly mount the arm onto the surface it uses as a base. To do this, refer to the installation documentation that came with the mounting arm.



NOTE:

When purchasing the arm please ensure that it is VESA compliant and that the arm has a 75 mm interface pad. If the mounting arm is not VESA compliant it cannot be used to support the AFL-xxA-N26 series flat panel PC. The AFL-10A-N26 and AFL-12A-N26 also support VESA MIS-D 100.

Step 2: Once the mounting arm has been firmly attached to the surface, lift the flat panel PC onto the interface pad of the mounting arm.

Step 3: Align the retention screw holes on the mounting arm interface with those in the flat panel PC. The AFL-W07A-N26 and AFL-08A-N26 arm mount retention screw holes are shown in **Figure 3-24** and the AFL-10A-N26 and AFL-12A-N26 are shown in **Figure 3-25**.

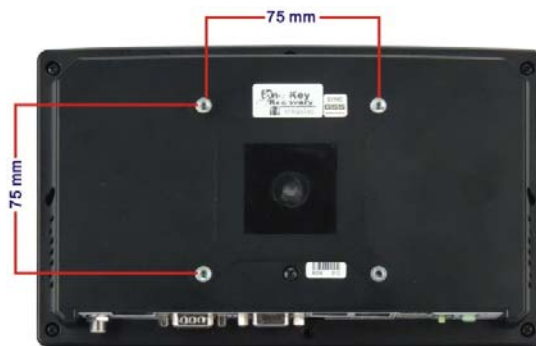

Figure 3-24: AFL-W07A-N26/AFL-08A-N26 Arm Mounting Retention Screw Holes

AFL-xxA-N26 Series Panel PC

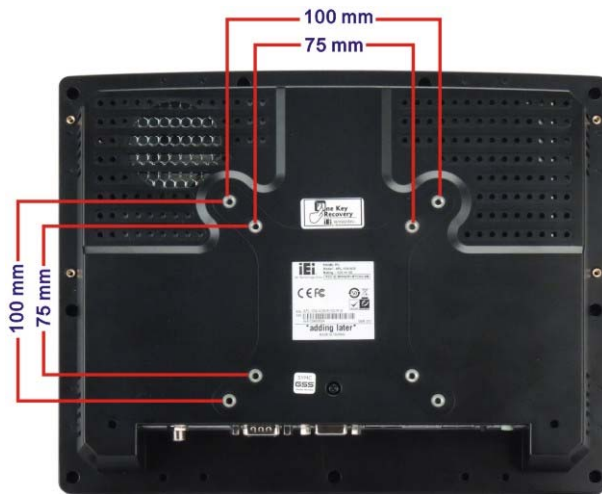

Figure 3-25: AFL-10A-N26/AFL-12A-N26 Arm Mounting Retention Screw Holes

Step 4: Secure the flat panel PC to the interface pad by inserting four retention screws through the bottom of the mounting arm interface pad and into the flat panel PC.

3.9.4 Cabinet and Rack Installation

The AFL-xxA-N26 series flat panel PC can be installed into a cabinet or rack. The installation procedures are similar to the panel mounting installation. To do this, please follow the steps below:



NOTE:

When purchasing the cabinet/rack installation bracket, make sure it is compatible with both the AFL-xxA-N26 series flat panel PC and the rack/cabinet into which the AFL-xxA-N26 series is installed.

Step 1: Slide the rear chassis of the AFL-xxA-N26 series flat panel PC through the rack/cabinet bracket until the aluminum frame is flush against the front of the bracket (**Figure 3-26**).

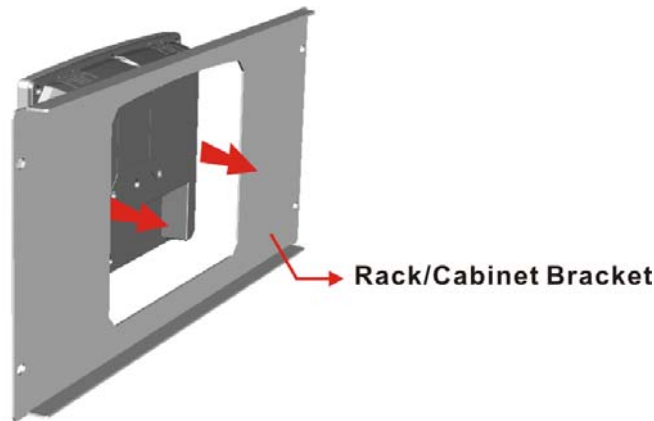

Figure 3-26: The Rack/Cabinet Bracket

Step 2: Insert the rack mounting clamps into the pre-formed holes along the edges of the flat panel PC, behind the ABS/PC plastic frame. There are a total of 4 rack mounting clamps for AFL-W07A-N26/AFL-08A-N26 and 6 rack mounting clamps for AFL-10A-N26/AFL-12A-N26.

Step 3: Tighten the screws that pass through the rack mounting clamps until the plastic caps at the front of all the screws are firmly secured to the bracket (**Figure 3-27**).

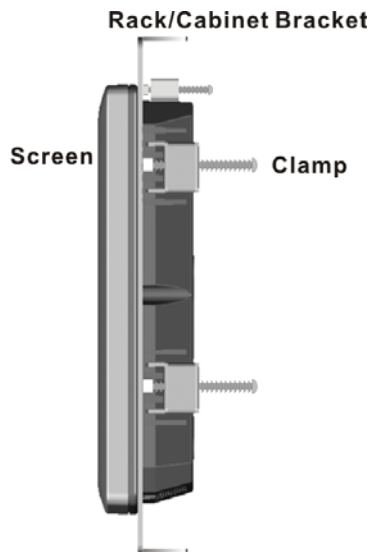

Figure 3-27: Secure the Rack/Cabinet Bracket (AFL-10A-N26/AFL-12A-N26)

Step 4: Slide the flat panel PC with the attached rack/cabinet bracket into a rack or cabinet (**Figure 3-28**).

AFL-xxA-N26 Series Panel PC

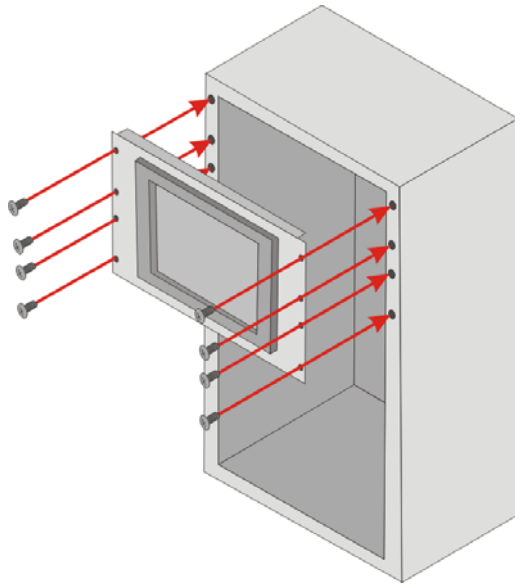

Figure 3-28: Install into a Rack/Cabinet

Step 5: Once the flat panel PC with the attached rack/cabinet bracket has been properly inserted into the rack or cabinet, secure the front of the rack/cabinet bracket to the front of the rack or cabinet (**Figure 3-28**).

3.10 Bottom Panel Connectors

3.10.1 LAN Connection

There are two external RJ-45 LAN connectors. The RJ-45 connector enables connection to an external network. To connect a LAN cable with an RJ-45 connector, please follow the instructions below.

Step 1: Locate the RJ-45 connectors on the bottom panel of the AFOLUX AFL-xxA-N26 Series.

Step 2: Align the connectors. Align the RJ-45 connector on the LAN cable with one of the RJ-45 connectors on the bottom panel of the AFOLUX AFL-xxA-N26 Series.

See **Figure 3-29**.

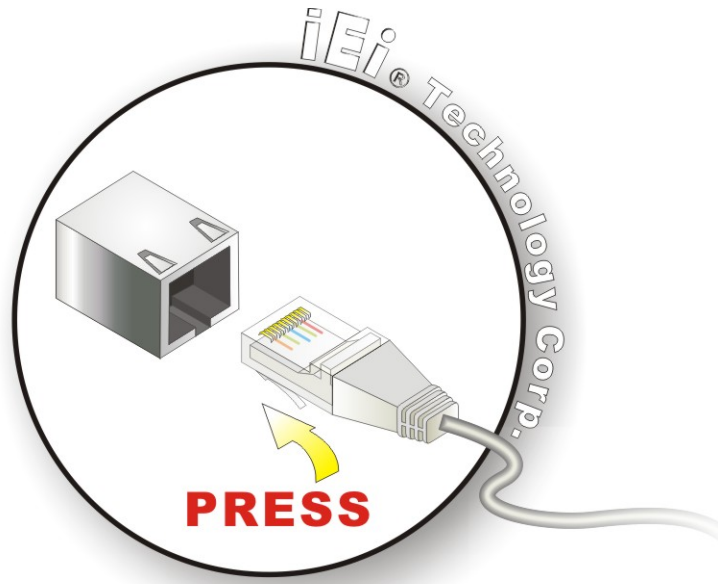

Figure 3-29: LAN Connection

Step 3: Insert the LAN cable RJ-45 connector. Once aligned, gently insert the LAN cable RJ-45 connector into the onboard RJ-45 connector.

3.10.2 Serial Device Connection (DB-9)

The AFOLUX AFL-xxA-N26 Series has one male DB-9 connector on the bottom panel for serial devices to be connected. Follow the steps below to connect a serial device to the AFOLUX AFL-xxA-N26 Series panel PC.

Step 1: Locate the DB-9 connector. The location of the DB-9 connector is shown in Chapter 1.

Step 2: Insert the serial connector. Insert the DB-9 connector of a serial device into the DB-9 connector on the bottom panel. See **Figure 3-30**.

AFL-xxA-N26 Series Panel PC

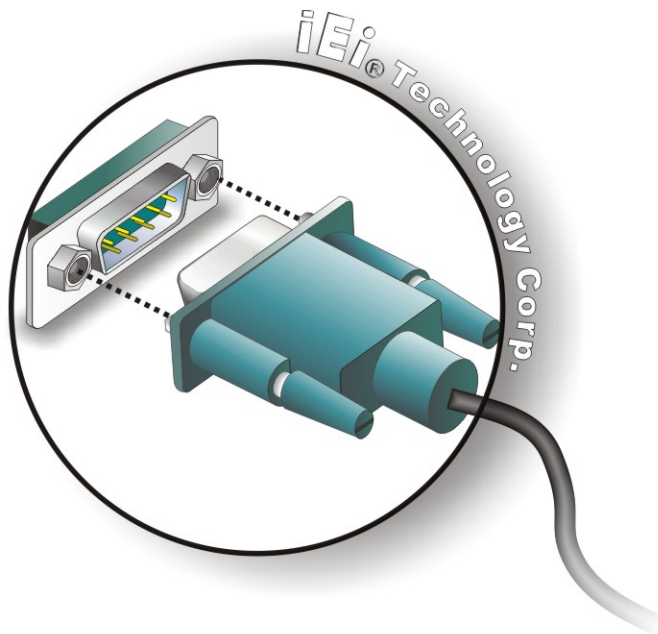

Figure 3-30: Serial Device Connector

Step 3: Secure the connector. Secure the serial device connector to the external interface by tightening the two retention screws on either side of the connector.

3.10.3 RJ-45 to DB-9 Serial Cable Connection

The AFL-xxA-N26 has one serial device connector on the bottom panel. The serial device slots (RJ-45) connect to a cable with a standard DB-9 connector at the other end. Follow the steps below to connect a serial device to the AFL-xxA-N26 panel PC.

Step 1: Locate the RJ-45 connector. The location of the RJ-45 serial port connector is shown in **Chapter 1**. The RJ-45 connector for the serial ports can be identified easily as the RJ-45 for the network has two LEDs on the port, while the connector for the serial cable don't.

Step 2: Insert the RJ-45 to DB-9 cable.

Step 3: Insert the serial connector. Insert the DB-9 connector of a serial device into the DB-9 connector on the cable. See Figure 3-30.

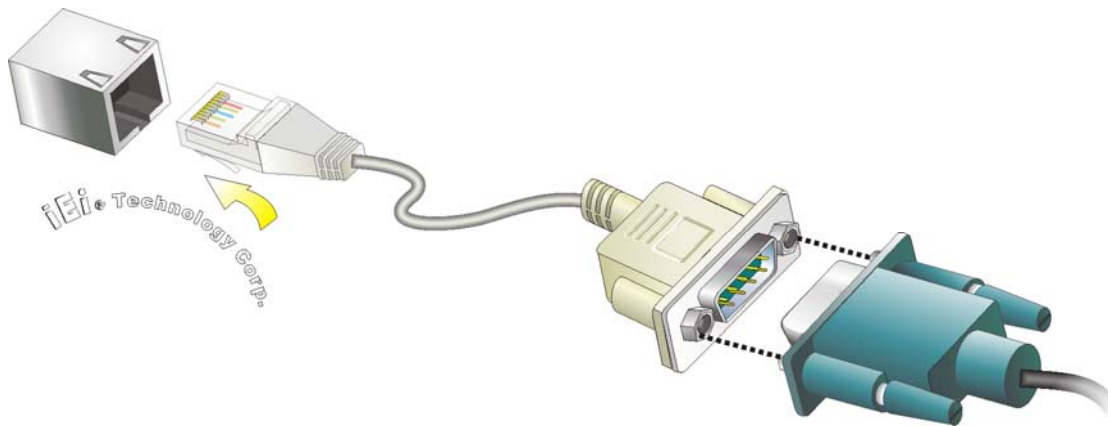

Figure 3-31: Serial Device Connector

Step 4: Secure the connector. Secure the serial device connector to the external interface by tightening the two retention screws on either side of the connector.

3.10.4 USB Device Connection

There are two external USB 2.0 connectors. To connect a USB 2.0 or USB 1.1 device, please follow the instructions below.

AFL-xxA-N26 Series Panel PC

Step 1: Located the **USB connectors**. The locations of the USB connectors are shown in **Chapter 1**.

Step 2: **Align the connectors.** Align the USB device connector with one of the connectors on the bottom panel. See **Figure 3-32**.

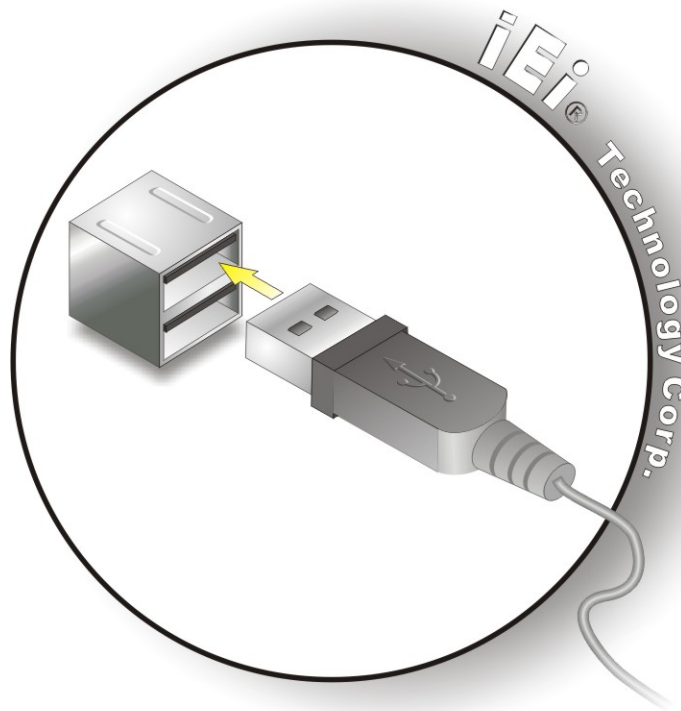

Figure 3-32: USB Device Connection

Step 3: **Insert the device connector.** Once aligned, gently insert the USB device connector into the onboard connector.

Chapter

4

System Maintenance

AFL-xxA-N26 Series Panel PC

4.1 System Maintenance Introduction

If the components of the AFOLUX AFL-xxA-N26 series fail they must be replaced.

Components that can be replaced include:

- Wireless LAN module
- SO-DIMM module
- mSATA SSD module

Please contact the system reseller or vendor to purchase the replacement parts. Back cover removal instructions for the AFOLUX AFL-xxA-N26 series are described below.

4.2 Anti-static Precautions



WARNING:

Failure to take ESD precautions during the maintenance of the AFL-xxA-N26 may result in permanent damage to the AFL-xxA-N26 and severe injury to the user.

Electrostatic discharge (ESD) can cause serious damage to electronic components, including the AFL-xxA-N26. Dry climates are especially susceptible to ESD. It is therefore critical that whenever the AFL-xxA-N26 is accessed internally, or any other electrical component is handled, the following anti-static precautions are strictly adhered to.

- ***Wear an anti-static wristband:*** - Wearing a simple anti-static wristband can help to prevent ESD from damaging the board.
- ***Self-grounding:*** - Before handling the board touch any grounded conducting material. During the time the board is handled, frequently touch any conducting materials that are connected to the ground.
- ***Use an anti-static pad:*** - When configuring the AFL-xxA-N26, place it on an anti-static pad. This reduces the possibility of ESD damaging the AFL-xxA-N26.
- ***Only handle the edges of the PCB:*** - When handling the PCB, hold the PCB by the edges.

4.3 Turn off the Power



WARNING:

Failing to turn off the system before opening it can cause permanent damage to the system and serious or fatal injury to the user.

Before any maintenance procedures are carried out on the system, make sure the system is turned off.

4.4 Opening the System



WARNING:

Over-tightening back cover screws will crack the plastic frame. Maximum torque for cover screws is 5 kg-cm (0.36 lb-ft/0.49 Nm).

To open the system, the back cover and the internal aluminum cover must be removed. Please follow the instruction described in **Section 3.4** to open the system.

4.5 Replacing Components

4.5.1 Memory Module Replacement

The flat panel PC is preinstalled with a 2 GB DDR3 memory module. If the memory module is fail, follow the instructions below to replace the memory module.

Step 1: Follow all anti-static procedures. See **Section 4.2**.

Step 2: Turn off the power. See **Section 4.3**.

Step 3: Remove the back cover and the internal aluminum back cover. See **Section 3.4**.

Step 4: Locate the DDR3 SO-DIMM on the motherboard (**Figure 4-1**).

AFL-xxA-N26 Series Panel PC

Pre-installed 2.0 GB 800 MHz DDR3 SO-DIMM

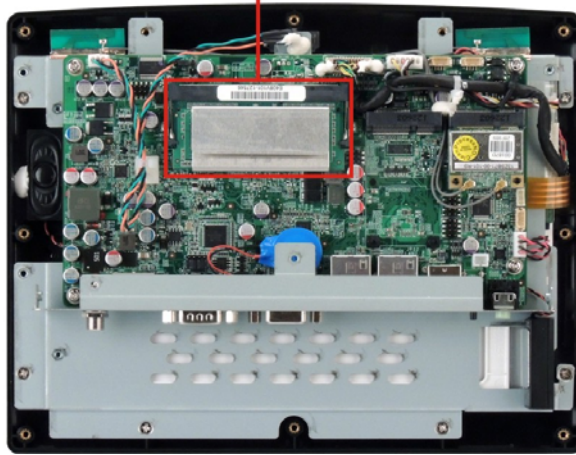

Figure 4-1: AFL-10A-N26 SO-DIMM Socket Location

- Step 5:** Remove the memory module by pulling both the spring retainer clips outward from the socket.
- Step 6:** Grasp the memory module by the edges and carefully pull it out of the socket.
- Step 7:** Install the new memory module by pushing it into the socket at an angle (**Figure 4-2**).
- Step 8:** Gently pull the spring retainer clips of the SO-DIMM socket out and push the rear of the memory module down (**Figure 4-2**).
- Step 9:** Release the spring retainer clips on the SO-DIMM socket. They clip into place and secure the memory module in the socket.

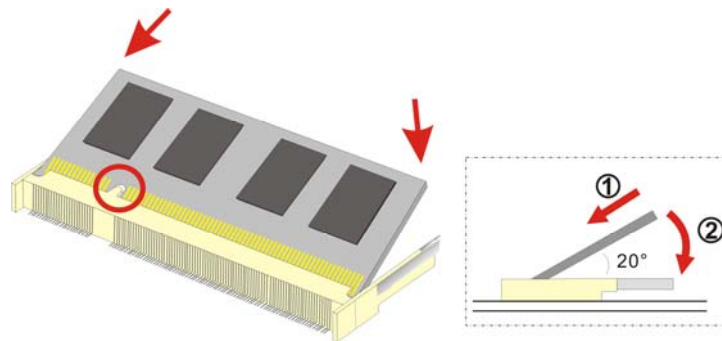

Figure 4-2: SO-DIMM Module Installation

4.5.2 WLAN Module Replacement

The AFOLUX AFL-xxA-N26 series is pre-installed one PCIe Mini wireless module. To replace the wireless module, follow the instructions below.

Step 1: Follow all anti-static procedures. See **Section 4.2**.

Step 2: Turn off the power. See **Section 4.3**.

Step 3: Remove the back cover and the internal aluminum back cover. See **Section 3.4**.

Step 4: Locate the WLAN module.

Step 5: Disconnect the antennas on the WLAN module (**Figure 4-3**).



Figure 4-3: Removing the Antennas

Step 6: Push the two spring clips in to release the WLAN module.



Figure 4-4: Releasing the WLAN Card

Step 7: Grasp the WLAN module by the edges and carefully pull it out of the socket.

AFL-xxA-N26 Series Panel PC

- Step 8:** Install a new WLAN module by inserting the card into the slot at an angle
- Step 9:** Push the WLAN module down until the spring retainer clips lock into place.
- Step 10:** Connect the two antennas.
- Step 11:** Replace the internal aluminum cover and the back cover. Secure them to the chassis using previously removed retention screws.

4.6 Reinstalling the Covers



WARNING:

Failing to reinstall the covers may result in permanent damage to the system. Please make sure all coverings are properly installed.

When maintenance procedures are complete, please make sure all the covers are replaced, including the following:

- Aluminum cover
- Plastic cover



Chapter

5

AMI BIOS Setup

5.1 Introduction

A licensed copy of AMI BIOS is preprogrammed into the ROM BIOS. The BIOS setup program allows users to modify the basic system configuration. This chapter describes how to access the BIOS setup program and the configuration options that may be changed.

5.1.1 Starting Setup

The AMI BIOS is activated when the computer is turned on. The setup program can be activated in one of two ways.

1. Press the **DELETE** key as soon as the system is turned on or
2. Press the **DELETE** key when the “**Press Del to enter SETUP**” message appears on the screen.

If the message disappears before the **DELETE** key is pressed, restart the computer and try again.

5.1.2 Using Setup

Use the arrow keys to highlight items, press **ENTER** to select, use the PageUp and PageDown keys to change entries, press **F1** for help and press **Esc** to quit. Navigation keys are shown in.

Key	Function
Up arrow	Move to previous item
Down arrow	Move to next item
Left arrow	Move to the item on the left hand side
Right arrow	Move to the item on the right hand side
+	Increase the numeric value or make changes
-	Decrease the numeric value or make changes
Esc key	Main Menu – Quit and not save changes into CMOS Status Page Setup Menu and Option Page Setup Menu -- Exit current page and return to Main Menu

F1 key	General help, only for Status Page Setup Menu and Option Page Setup Menu
F2 key	Load previous values
F3 key	Load optimized defaults
F4 key	Save changes and Exit BIOS

Table 5-1: BIOS Navigation Keys

5.1.3 Getting Help

When **F1** is pressed a small help window describing the appropriate keys to use and the possible selections for the highlighted item appears. To exit the Help Window press **Esc** or the **F1** key again.

5.1.4 Unable to Reboot After Configuration Changes

If the computer cannot boot after changes to the system configuration is made, CMOS defaults. Use the jumper described in **Chapter 5**.

5.1.5 BIOS Menu Bar

The **menu bar** on top of the BIOS screen has the following main items:

- Main – Changes the basic system configuration.
- Advanced – Changes the advanced system settings.
- Chipset – Changes the chipset settings.
- Boot – Changes the system boot configuration.
- Security – Sets User and Supervisor Passwords.
- Save & Exit – Selects exit options and loads default settings

The following sections completely describe the configuration options found in the menu items at the top of the BIOS screen and listed above.

AFL-xxA-N26 Series Panel PC

5.2 Main

The **Main** BIOS menu (**BIOS Menu 1**) appears when the **BIOS Setup** program is entered. The **Main** menu gives an overview of the basic system information.

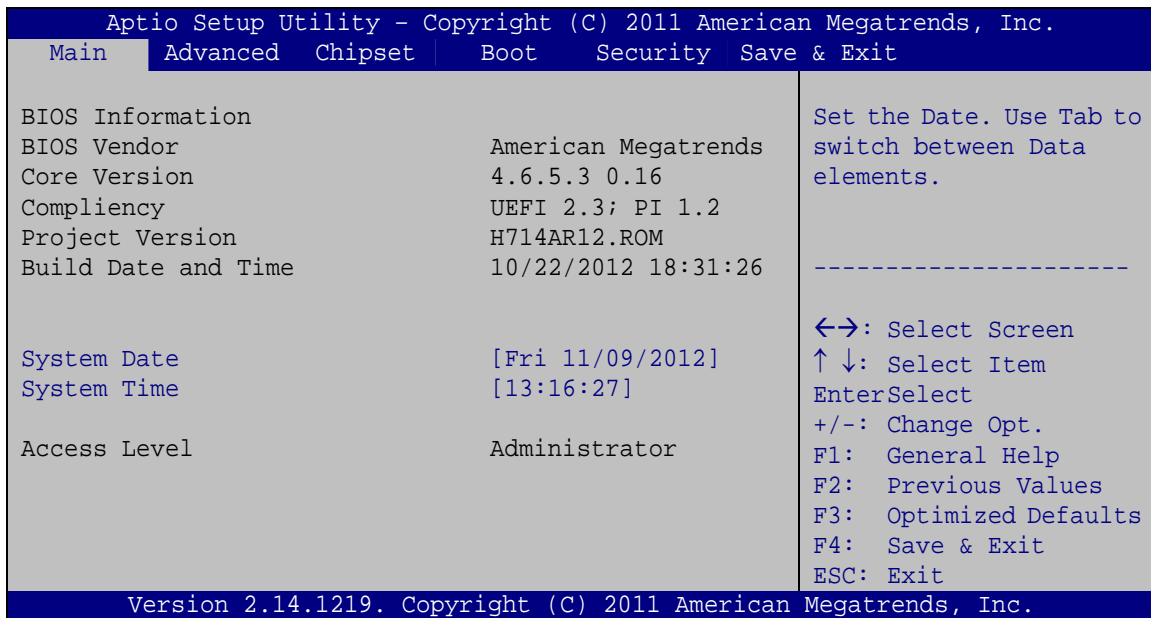

BIOS Menu 1: Main

→ BIOS Information

The **BIOS Information** lists a brief summary of the BIOS. The fields in **BIOS Information** cannot be changed. The items shown in the system overview include:

- **BIOS Vendor:** Installed BIOS vendor
- **Core Version:** Current BIOS version
- **Compliency:** Current compliant version
- **Project Version:** the board version
- **Build Date and Time:** Date the current BIOS version was made

→ System Date [xx/xx/xx]

Use the **System Date** option to set the system date. Manually enter the day, month and year.

→ **System Time [xx:xx:xx]**

Use the **System Time** option to set the system time. Manually enter the hours, minutes and seconds.

5.3 Advanced

Use the **Advanced** menu (**BIOS Menu 2**) to configure the CPU and peripheral devices through the following sub-menus:



WARNING:

Setting the wrong values in the sections below may cause the system to malfunction. Make sure that the settings made are compatible with the hardware.

- ACPI Settings
- RTC Wake Settings
- CPU Configuration
- IDE Configuration
- USB Configuration
- F81866 Super IO Configuration
- F81866 H/W Monitor
- Serial Port Console Redirection
- iEi Feature

AFL-xxA-N26 Series Panel PC

```

Aptio Setup Utility - Copyright (C) 2011 American Megatrends, Inc.
Main  Advanced  Chipset  Boot  Security  Save & Exit

> ACPI Settings
> RTC Wake Settings
> CPU Configuration
> IDE Configuration
> USB Configuration
> F81866 Super IO Configuration
> F81866 H/M Monitor
> Serial Port Console Redirection
> iEi Feature

System ACPI Parameters.

-----

<=>: Select Screen
↑↓: Select Item
EnterSelect
+/-: Change Opt.
F1: General Help
F2: Previous Values
F3: Optimized Defaults
F4: Save & Exit
ESC: Exit

Version 2.14.1219. Copyright (C) 2011 American Megatrends, Inc.

```

BIOS Menu 2: Advanced

5.3.1 ACPI Settings

The **ACPI Settings** menu (**BIOS Menu 3**) configures the Advanced Configuration and Power Interface (ACPI) options.

```

Aptio Setup Utility - Copyright (C) 2011 American Megatrends, Inc.
Advanced

ACPI Settings
ACPI Sleep State          [S1 (CPU Stop Clock)]

Select the highest ACPI
sleep state the system
will enter, when the
SUSPEND button is
pressed.

-----

<=>: Select Screen
↑↓: Select Item
EnterSelect
+/-: Change Opt.
F1: General Help
F2: Previous Values
F3: Optimized Defaults
F4: Save & Exit
ESC: Exit

Version 2.14.1219. Copyright (C) 2011 American Megatrends, Inc.

```

BIOS Menu 3: ACPI Configuration

➔ **ACPI Sleep State [S1 (CPU Stop Clock)]**

Use the **ACPI Sleep State** option to specify the sleep state the system enters when it is not being used.

- ➔ **S1 (CPU Stop Clock)** **DEFAULT** The system enters S1 (POS) sleep state. The system appears off. The CPU is stopped; RAM is refreshed; the system is running in a low power mode.
- ➔ **S3 (Suspend to RAM)** The caches are flushed and the CPU is powered off. Power to the RAM is maintained. The computer returns slower to a working state, but more power is saved.

5.3.2 RTC Wake Settings

The **RTC Wake Settings** menu (**BIOS Menu 4**) configures RTC wake event.

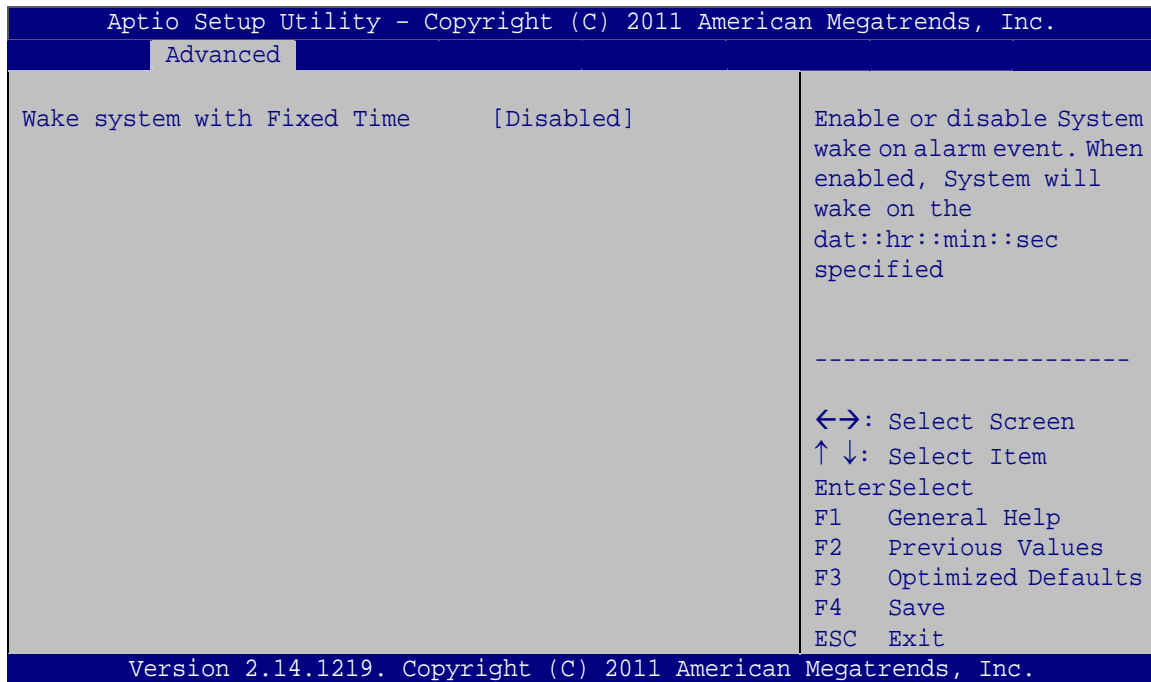

BIOS Menu 4: RTC Wake Settings

AFL-xxA-N26 Series Panel PC

→ Wake System with Fixed Time [Disabled]

Use the **Wake System with Fixed Time** option to specify the time the system should be roused from a suspended state.

- **Disabled** **DEFAULT** The real time clock (RTC) cannot generate a wake event

- **Enabled** If selected, the following appears with values that can be selected:
 - *Wake up every day
 - *Wake up date
 - *Wake up hour
 - *Wake up minute
 - *Wake up second

After setting the alarm, the computer turns itself on from a suspend state when the alarm goes off.

5.3.3 CPU Configuration

Use the **CPU Configuration** menu (**BIOS Menu 5**) to enter the **CPU Information** submenu or enable Intel Virtualization Technology.

Aptio Setup Utility - Copyright (C) 2011 American Megatrends, Inc.		
Advanced		
CPU Configuration		Enabled for Windows XP and Linux (OS optimized for Hyper-Threading Technology and Disabled for other OS (OS not optimized for Hyper-Threading Technology)).
Processor Type	Intel(R) Atom(TM) CPU N2600 @ 1.60GHz	
EMT64	Supported	
Processor Speed	1600 MHz	
System Bus Speed	400 MHz	
Ratio Status	16	
Actual Ratio	16	
System Bus Speed	400 MHz	
Processor Stepping	30661	
Microcode Revision	269	
L1 Cache RAM	2x56 k	
L2 Cache RAM	2x512 k	
Processor Core	Dual	
Hyper-Threading	Supported	
Hyper-threading	[Enabled]	
		←→: Select Screen ↑ ↓: Select Item Enter>Select +/-: Change Opt. F1: General Help F2: Previous Values F3: Optimized Defaults F4: Save & Exit ESC: Exit
Version 2.14.1219. Copyright (C) 2011 American Megatrends, Inc.		

BIOS Menu 5: CPU Configuration

The CPU Configuration menu lists the following CPU details:

- Processor Type: Lists the brand name of the CPU being used
- EMT64: Indicates if EM64T is supported by the CPU.
- Processor Speed: Lists the CPU processing speed
- System Bus Speed: Lists the system bus speed
- Ratio Status: Lists the ratio status
- Actual Ratio: Lists the actual ratio
- Processor Stepping: Lists the CPU processing stepping
- Microcode Revision: Lists the microcode revision
- L1 Cache RAM: Lists the amount of storage space on the L1 Cache
- L2 Cache RAM: Lists the amount of storage space on the L2 Cache
- Processor Core: Lists the number of the processor cores
- Hyper-Threading: Indicates if Hyper-Threading is supported by the CPU.

AFL-xxA-N26 Series Panel PC

→ Hyper-threading [Enabled]

Use the Hyper-threading function to enable or disable the CPU hyper threading function.

- **Disabled** Disables the use of hyper-threading technology
- **Enabled DEFAULT** Enables the use of hyper-threading technology

5.3.4 IDE Configuration

Use the **IDE Configuration** menu (**BIOS Menu 6**) to change and/or set the configuration of the IDE devices installed in the system.

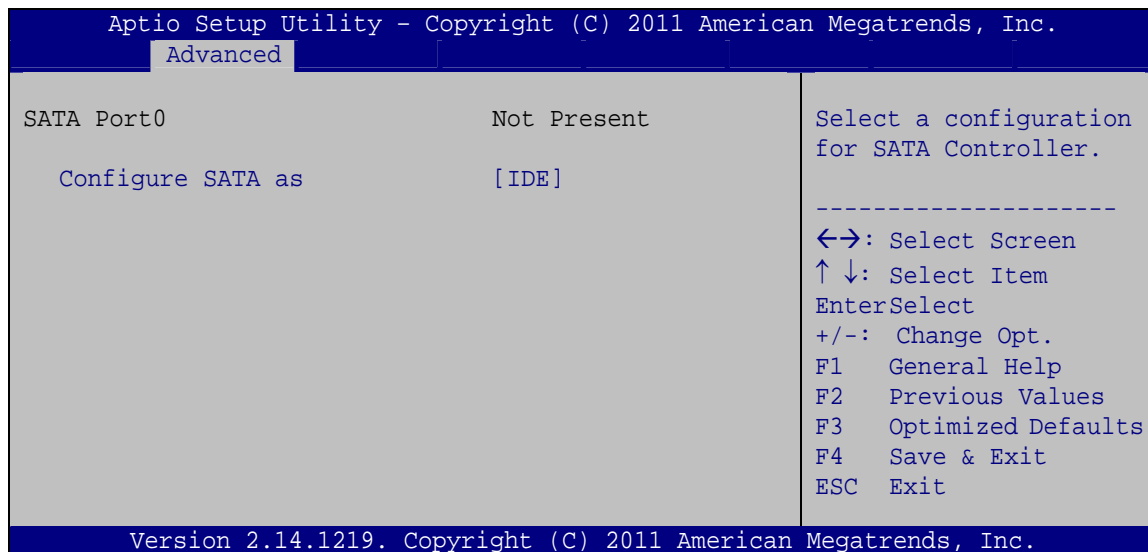

BIOS Menu 6: IDE Configuration

→ Configure SATA as [IDE]

Use the **Configure SATA as** option to configure SATA devices as normal IDE devices.

- **IDE DEFAULT** Configures SATA devices as normal IDE device.
- **AHCI** The SATA drive connected to the nth SATA drive port is specified as a normal SATA drive.

5.3.5 USB Configuration

Use the **USB Configuration** menu (**BIOS Menu 7**) to read USB configuration information and configure the USB settings.

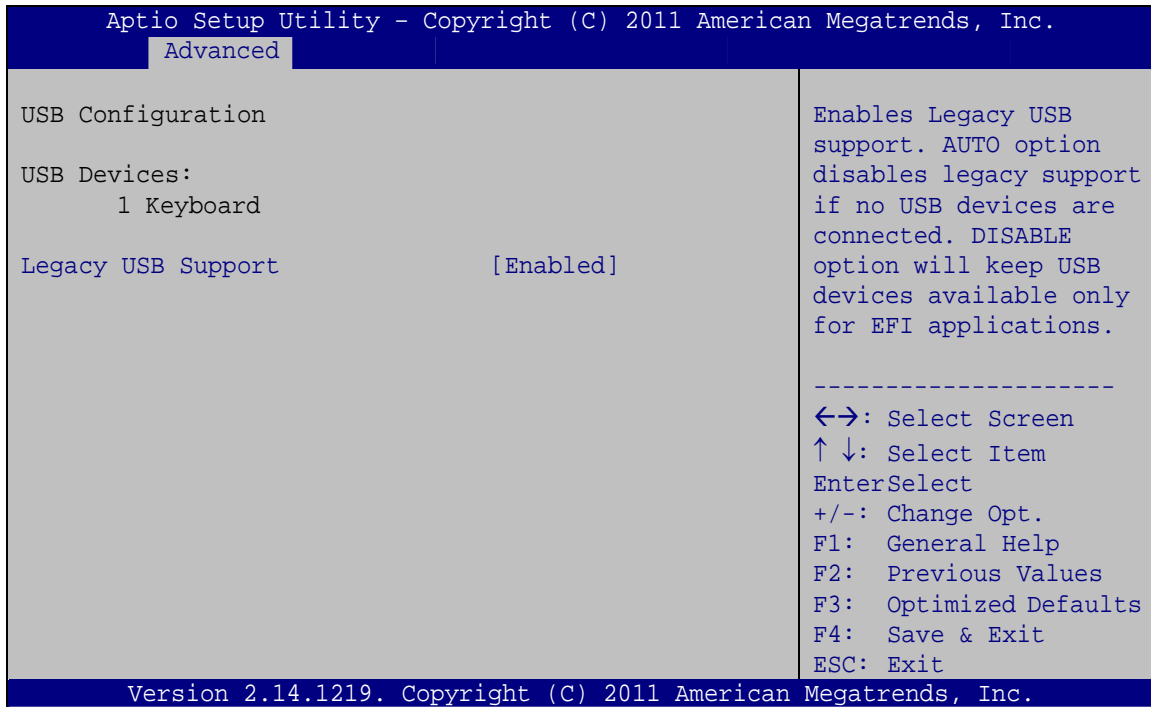

BIOS Menu 7: USB Configuration

➔ USB Devices

The **USB Devices Enabled** field lists the USB devices that are enabled on the system

➔ Legacy USB Support [Enabled]

Use the **Legacy USB Support** BIOS option to enable USB mouse and USB keyboard support. Normally if this option is not enabled, any attached USB mouse or USB keyboard does not become available until a USB compatible operating system is fully booted with all USB drivers loaded. When this option is enabled, any attached USB mouse or USB keyboard can control the system even when there is no USB driver loaded onto the system.

➔ **Enabled** **DEFAULT** Legacy USB support enabled

AFL-xxA-N26 Series Panel PC

- ➔ **Disabled** Legacy USB support disabled
- ➔ **Auto** Legacy USB support disabled if no USB devices are connected

5.3.6 F81866 Super IO Configuration

Use the **F81866 Super IO Configuration** menu (**BIOS Menu 8**) to set or change the configurations for the serial ports.

```

Aptio Setup Utility - Copyright (C) 2011 American Megatrends, Inc.
  Advanced
F81866 Super IO Configuration
F81866 Super IO Chip          F81866
> Serial Port 1 Configuration
> Serial Port 3 Configuration
> Serial Port 4 Configuration

Set Parameters of Serial Port 0 (COMA)
-----
<=>: Select Screen
↑↓: Select Item
Enter>Select
+/-: Change Opt.
F1:  General Help
F2:  Previous Values
F3:  Optimized Defaults
F4:  Save & Exit
ESC: Exit

Version 2.11.1210. Copyright (C) 2011 American Megatrends, Inc.
  
```

BIOS Menu 8: F81866 Super IO Configuration

5.3.6.1 Serial Port n Configuration

Use the **Serial Port n Configuration** menu (**BIOS Menu 9**) to configure the serial port n.

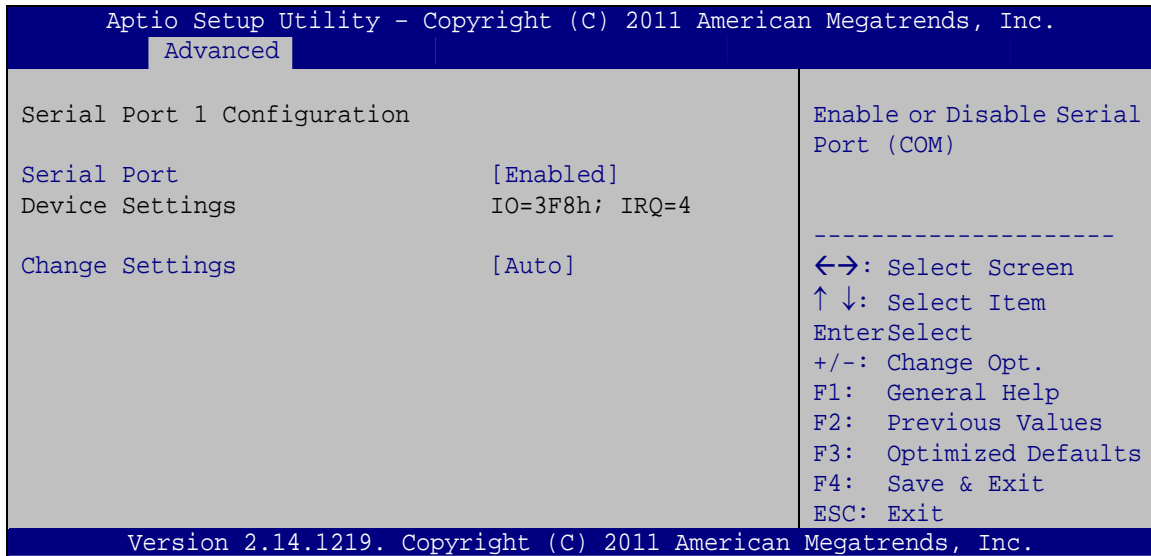

BIOS Menu 9: Serial Port n Configuration Menu

5.3.6.1.1 Serial Port 1 Configuration

→ Serial Port [Enabled]

Use the **Serial Port** option to enable or disable the serial port.

- **Disabled** Disable the serial port
- **Enabled** **DEFAULT** Enable the serial port

→ Change Settings [Auto]

Use the **Change Settings** option to change the serial port IO port address and interrupt address.

- **Auto** **DEFAULT** The serial port IO port address and interrupt address are automatically detected.
- **IO=3F8h; IRQ=4** Serial Port I/O port address is 3F8h and the interrupt address is IRQ4

AFL-xxA-N26 Series Panel PC

- ➔ **IO=3F8h; IRQ=3, 4** Serial Port I/O port address is 3F8h and the interrupt address is IRQ3, 4
- ➔ **IO=2F8h; IRQ=3, 4** Serial Port I/O port address is 2F8h and the interrupt address is IRQ3, 4
- ➔ **IO=3E8h; IRQ=3, 4** Serial Port I/O port address is 3E8h and the interrupt address is IRQ3, 4
- ➔ **IO=2E8h; IRQ=3, 4** Serial Port I/O port address is 2E8h and the interrupt address is IRQ3, 4

5.3.6.1.2 Serial Port 3 Configuration

➔ Serial Port [Enabled]

Use the **Serial Port** option to enable or disable the serial port.

- ➔ **Disabled** Disable the serial port
- ➔ **Enabled** **DEFAULT** Enable the serial port

➔ Change Settings [Auto]

Use the **Change Settings** option to change the serial port IO port address and interrupt address.

- ➔ **Auto** **DEFAULT** The serial port IO port address and interrupt address are automatically detected.
- ➔ **IO=3E8h; IRQ=10** Serial Port I/O port address is 3E8h and the interrupt address is IRQ10
- ➔ **IO=3F8h; IRQ=10,11** Serial Port I/O port address is 3F8h and the interrupt address is IRQ10, 11
- ➔ **IO=2F8h; IRQ=10,11** Serial Port I/O port address is 2F8h and the interrupt address is IRQ10, 11
- ➔ **IO=3E8h; IRQ=10,11** Serial Port I/O port address is 3E8h and the interrupt address is IRQ10, 11

- **IO=2E8h;**
IRQ=10,11 Serial Port I/O port address is 2E8h and the interrupt address is IRQ10, 11
- **IO=250h;**
IRQ=10,11 Serial Port I/O port address is 250h and the interrupt address is IRQ10, 11
- **IO=2E0h;**
IRQ=10,11 Serial Port I/O port address is 2E0h and the interrupt address is IRQ10, 11

5.3.6.1.3 Serial Port 4 Configuration

→ Serial Port [Enabled]

Use the **Serial Port** option to enable or disable the serial port.

- **Disabled** Disable the serial port
- **Enabled** **DEFAULT** Enable the serial port

→ Change Settings [Auto]

Use the **Change Settings** option to change the serial port IO port address and interrupt address.

- **Auto** **DEFAULT** The serial port IO port address and interrupt address are automatically detected.
- **IO=2E8h; IRQ=10** Serial Port I/O port address is 2E8h and the interrupt address is IRQ10
- **IO=3F8h;**
IRQ=10,11 Serial Port I/O port address is 3F8h and the interrupt address is IRQ10, 11
- **IO=2F8h;**
IRQ=10,11 Serial Port I/O port address is 2F8h and the interrupt address is IRQ10, 11
- **IO=3E8h;**
IRQ=10,11 Serial Port I/O port address is 3E8h and the interrupt address is IRQ10, 11
- **IO=2E8h;**
IRQ=10,11 Serial Port I/O port address is 2E8h and the interrupt address is IRQ10, 11

AFL-xxA-N26 Series Panel PC

- ➔ **IO=250h;**
IRQ=10,11 Serial Port I/O port address is 250h and the interrupt address is IRQ10, 11
- ➔ **IO=2E0h;**
IRQ=10,11 Serial Port I/O port address is 2E0h and the interrupt address is IRQ10, 11

5.3.7 F81866 H/W Monitor

The F81866 H/W Monitor menu (**BIOS Menu 10**) shows the operating temperature, fan speeds and system voltages.

```

Aptio Setup Utility - Copyright (C) 2011 American Megatrends, Inc.
Advanced
>Smart Fan Mode Configuration
System Temperature          : +35 C

Smart Fan Mode Select
-----
<=>: Select Screen
↑↓: Select Item
EnterSelect
+/-: Change Opt.
F1: General Help
F2: Previous Values
F3: Optimized Defaults
F4: Save & Exit
ESC: Exit

Version 2.14.1219. Copyright (C) 2011 American Megatrends, Inc.
  
```

BIOS Menu 10: Hardware Health Configuration

➔ Hardware Health Status

The following system parameters and values is shown. The system parameter that is monitored is:

- System Temperature

5.3.7.1 Smart Fan Mode Configuration

Use the **Smart Fan Mode Configuration** submenu (**BIOS Menu 11**) to configure smart fan temperature and speed settings.

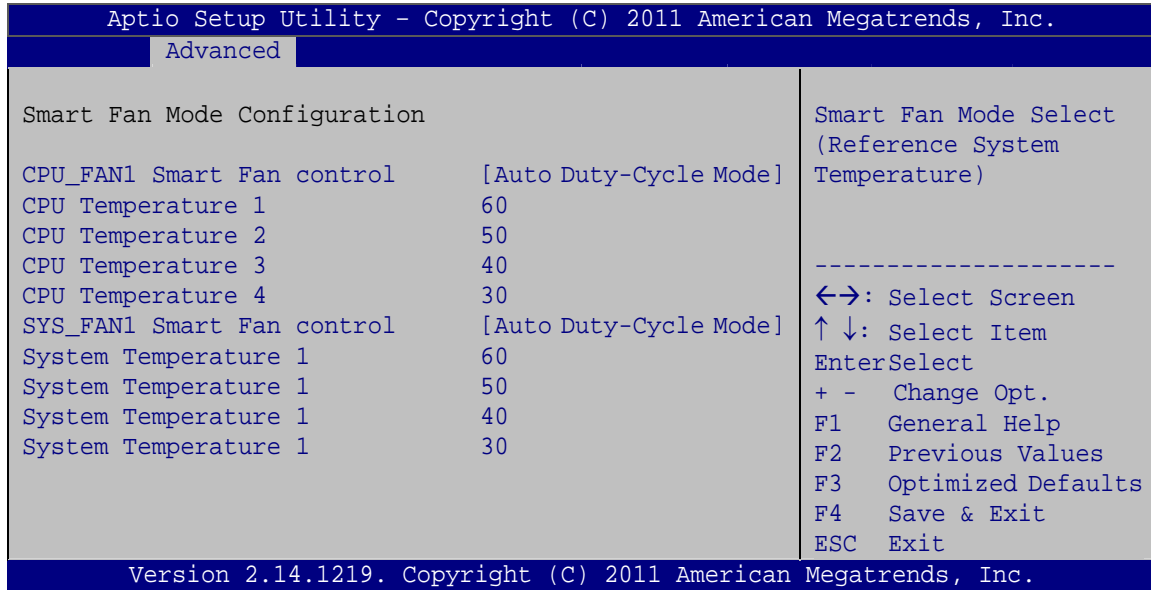

BIOS Menu 11: Smart Fan Mode Configuration

→ CPU_FAN1 Smart Fan control [Auto Duty-Cycle Mode]

Use the **CPU_FAN1 Smart Fan control** option to configure the CPU Smart Fan.

- **Manual Duty Mode** The fan spins at the speed set in Manual by Duty Cycle settings
- **Auto Duty-Cycle Mode** The fan adjusts its speed using Auto by Duty-Cycle settings

→ CPU Temperature n

Use the + or – key to change the **CPU Temperature n** value. Enter a decimal number between 1 and 100.

→ SYS_FAN1 Smart Fan control [Auto Duty-Cycle Mode]

Use the **SYS_FAN1 Smart Fan control** option to configure the System Smart Fan.

- **Manual Duty Mode** The fan spins at the speed set in Manual by Duty Cycle settings

AFL-xxA-N26 Series Panel PC

➔ **Auto Duty-Cycle Mode** **DEFAULT** The fan adjusts its speed using Auto by Duty-Cycle settings

➔ System Temperature n

Use the + or – key to change the **System Temperature n** value. Enter a decimal number between 1 and 100.

5.3.8 Serial Port Console Redirection

The **Serial Port Console Redirection** menu (**BIOS Menu 12**) allows the console redirection options to be configured. Console redirection allows users to maintain a system remotely by re-directing keyboard input and text output through the serial port.

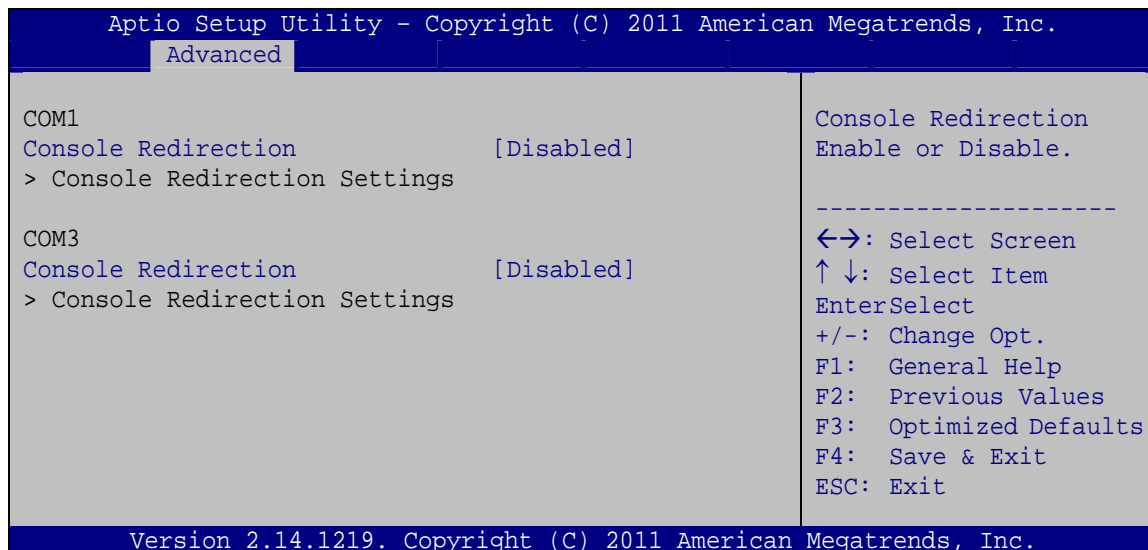

BIOS Menu 12: Serial Port Console Redirection

➔ Console Redirection [Disabled]

Use **Console Redirection** option to enable or disable the console redirection function.

➔ **Disabled** **DEFAULT** Disabled the console redirection function

➔ **Enabled** Enabled the console redirection function

5.4 iEi Feature

Use the **iEi Feature** menu (**BIOS Menu 13**) to configure the auto recovery function.

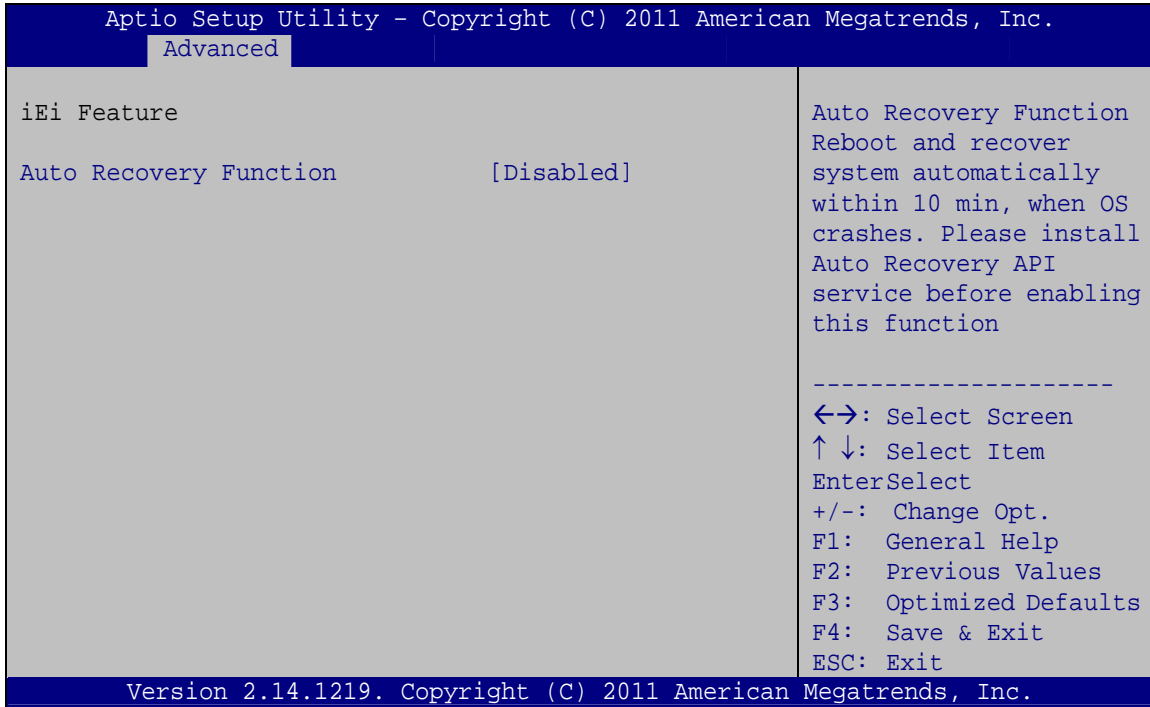

BIOS Menu 13: iEi Feature

➔ Auto Recovery Function [Disabled]

Use the **Auto Recovery Function** option to enable or disable auto recovery on the system.

- ➔ **Disabled** **DEFAULT** Auto Recovery Function support disabled
- ➔ **Enabled** Auto Recovery Function support enabled

AFL-xxA-N26 Series Panel PC

5.5 Chipset

Use the **Chipset** menu (**BIOS Menu 14**) to access the North Bridge, South Bridge, Integrated Graphics, and ME Subsystem configuration menus.



WARNING!

Setting the wrong values for the Chipset BIOS selections in the Chipset BIOS menu may cause the system to malfunction.

```

Aptio Setup Utility - Copyright (C) 2011 American Megatrends, Inc.
Main   Advanced  Chipset  Boot   Security  Save & Exit
-----
> Host Bridge
> South Bridge

North Bridge Parameters
-----
<=>: Select Screen
↑ ↓: Select Item
EnterSelect
+ - Change Opt.
F1  General Help
F2  Previous Values
F3  Optimized Defaults
F4  Save & Exit
ESC Exit

Version 2.14.1219. Copyright (C) 2011 American Megatrends, Inc.
  
```

BIOS Menu 14: Chipset

5.5.1 Host Bridge Configuration

Use the **Host Bridge** menu (**BIOS Menu 15**) to configure the Host Bridge chipset.

```

Aptio Setup Utility - Copyright (C) 2011 American Megatrends, Inc.
  Chipset
-----
>Intel IGD Configuration
***** Memory Information *****
Memory Frequency          800 MHz(DDR3)
Total Memory              2048 MB
DIMM#1                   2048 MB

Select which graphics controller to use as the primary boot device.

-----
<->: Select Screen
↑↓: Select Item
Enter>Select
+ - Change Opt.
F1  General Help
F2  Previous Values
F3  Optimized Defaults
F4  Save & Exit
ESC Exit

Version 2.14.1219. Copyright (C) 2011 American Megatrends, Inc.
  
```

BIOS Menu 15: Host Bridge Configuration

5.5.1.1 Intel IGD Configuration

Use the **Intel IGD Configuration** menu (**BIOS Menu 16**) to configure the video device connected to the system.

```

Aptio Setup Utility - Copyright (C) 2011 American Megatrends, Inc.
  Advanced
-----
Intel IGD Configuration
IGD - Boot Type          [VBIOS Default]
LVDS Panel Type         [800x480 LVDS]
Backlight Control       [Inverted]
Fixed Graphics Memory Size [128MB]

Configure Fixed Graphics Memory Size

-----
<->: Select Screen
↑↓: Select Item
Enter>Select
+/-: Change Opt.
F1  General Help
F2  Previous Values
F3  Optimized Defaults
F4  Save
ESC Exit

Version 2.14.1219. Copyright (C) 2011 American Megatrends, Inc.
  
```

BIOS Menu 16: Intel IGD Configuration

AFL-xxA-N26 Series Panel PC

→ Fixed Graphics Memory Size [128MB]

Use the **Fixed Graphics Memory Size** option to specify the maximum amount of memory that can be allocated as graphics memory. Configuration options are listed below.

- 128 MB **DEFAULT**
- 256 MB

5.5.2 South Bridge Configuration

Use the **South Bridge** menu (**BIOS Menu 17**) to configure the Southbridge chipset.

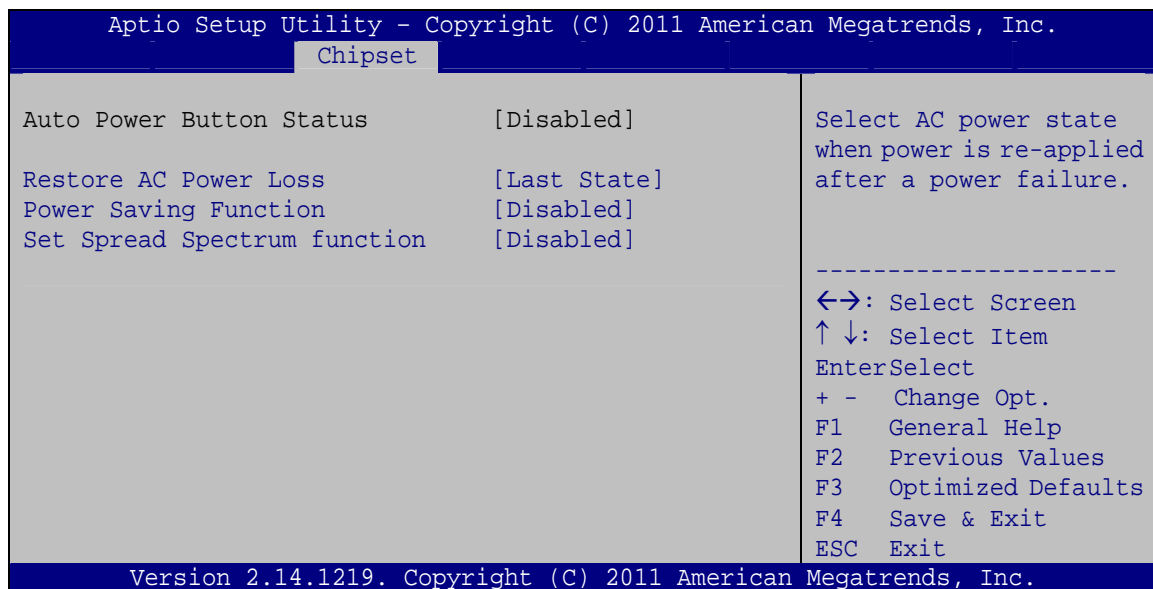

BIOS Menu 17: South Bridge Configuration

→ Restore AC Power Loss [Last State]

Use the **Restore AC Power Loss** BIOS option to specify what state the system returns to if there is a sudden loss of power to the system.

- **Power Off** The system remains turned off
- **Power On** The system turns on
- **Last State** **DEFAULT** The system returns to its previous state. If it was on, it turns itself on. If it was off, it remains off.

→ **Power Saving Function [Disabled]**

Use the **Power Saving Function** BIOS option to enable or disable the power saving function.

- **Disabled** **DEFAULT** Power saving function is disabled.
- **Enabled** Power saving function is enabled. It will reduce power consumption when the system is off.

→ **Set Spread Spectrum function [Disabled]**

Use the **Set Spread Spectrum function** option to reduce the EMI. Excess EMI is generated when the system clock generator pulses have extreme values. Spreading the pulse spectrum modulates changes in the extreme values from spikes to flat curves, thus reducing the EMI. This benefit may in some cases be outweighed by problems with timing-critical devices, such as a clock-sensitive SCSI device.

- **Disabled** **DEFAULT** EMI not reduced
- **Enabled** EMI reduced

AFL-xxA-N26 Series Panel PC

5.6 Boot

Use the **Boot** menu (**BIOS Menu 18**) to configure system boot options.

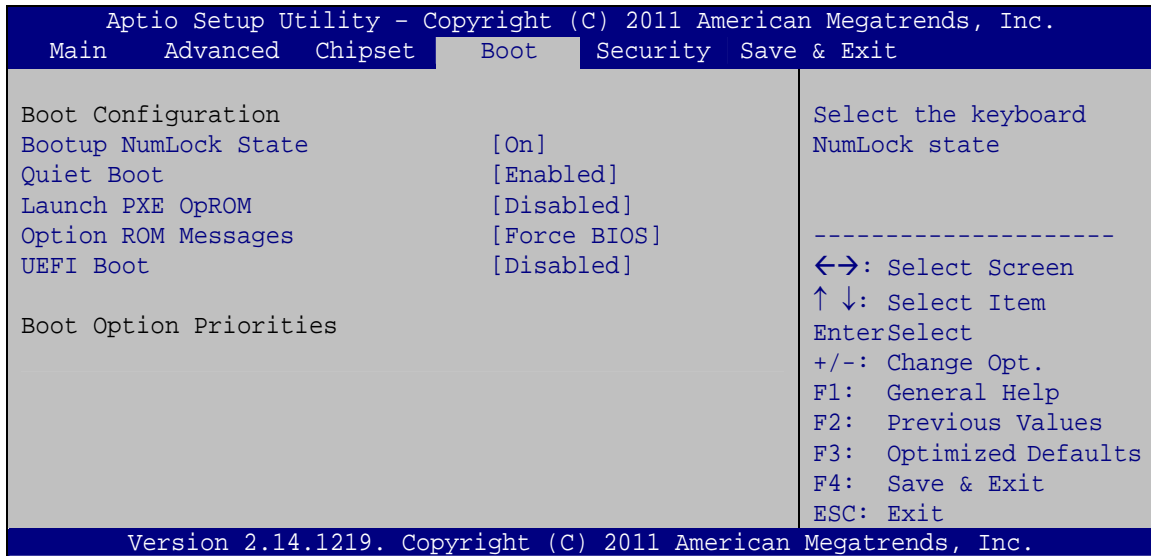

BIOS Menu 18: Boot

→ Bootup NumLock State [On]

Use the **Bootup NumLock State** BIOS option to specify if the number lock setting must be modified during boot up.

→ **On** **DEFAULT** Allows the Number Lock on the keyboard to be enabled automatically when the computer system boots up. This allows the immediate use of the 10-key numeric keypad located on the right side of the keyboard. To confirm this, the Number Lock LED light on the keyboard is lit.

→ **Off** Does not enable the keyboard Number Lock automatically. To use the 10-keys on the keyboard, press the Number Lock key located on the upper left-hand corner of the 10-key pad. The Number Lock LED on the keyboard lights up when the Number Lock is engaged.

→ Quiet Boot [Enabled]

Use the **Quiet Boot** BIOS option to select the screen display when the system boots.

- **Disabled** Normal POST messages displayed
- **Enabled** **DEFAULT** OEM Logo displayed instead of POST messages

→ Launch PXE OpROM [Disabled]

Use the **Launch PXE OpROM** option to enable or disable boot option for legacy network devices.

- **Disabled** **DEFAULT** Ignore all PXE Option ROMs
- **Enabled** Load PXE Option ROMs

→ Option ROM Messages [Force BIOS]

Use the **Option ROM Messages** option to set the Option ROM display mode.

- **Force BIOS** **DEFAULT** Sets display mode to force BIOS.
- **Keep Current** Sets display mode to current.

→ UEFI Boot [Disabled]

Use **UEFI Boot** to enable or disable booting from the UEFI drive.

- **Disabled** **DEFAULT** Disables boot option.
- **Enabled** Enables booting from the UEFI device.

5.7 Security

Use the **Security** menu (**BIOS Menu 19**) to set system and user passwords.

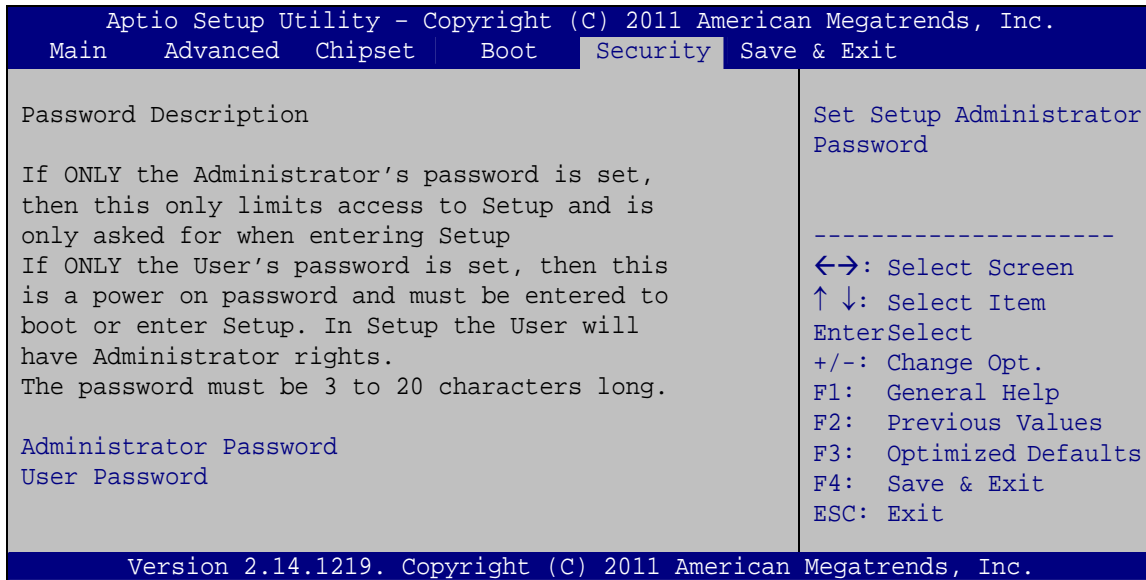

BIOS Menu 19: Security

➔ Administrator Password

Use the **Administrator Password** field to set or change an administrator password.

➔ User Password

Use the **User Password** field to set or change a user password.

5.8 Save & Exit

Use the **Save & Exit** menu (**BIOS Menu 20**) to load default BIOS values, optimal failsafe values and to save configuration changes.

```

Aptio Setup Utility - Copyright (C) 2011 American Megatrends, Inc.
Main   Advanced  Chipset  Boot   Security  Save & Exit

Save Changes and Reset
Discard Changes and Reset

Restore Defaults
Save as User Defaults
Restore User Defaults

Reset the system after
saving the changes.

-----
<->: Select Screen
↑ ↓: Select Item
Enter>Select
+/-: Change Opt.
F1:  General Help
F2:  Previous Values
F3:  Optimized Defaults
F4:  Save & Exit
ESC: Exit

Version 2.14.1219. Copyright (C) 2011 American Megatrends, Inc.
  
```

BIOS Menu 20: Exit

→ Save Changes and Reset

Use the **Save Changes and Reset** option to save the changes made to the BIOS options and reset the system.

→ Discard Changes and Reset

Use the **Discard Changes and Reset** option to exit the system without saving the changes made to the BIOS configuration setup program.

→ Restore Defaults

Use the **Restore Defaults** option to load the optimal default values for each of the parameters on the Setup menus. **F3 key can be used for this operation.**

AFL-xxA-N26 Series Panel PC

→ Save as User Defaults

Use the **Save as User Defaults** option to save the changes done so far as user defaults.

→ Restore User Defaults

Use the **Restore User Defaults** option to restore the user defaults to all the setup options.

Chapter

6

Software Drivers

6.1 Available Software Drivers



NOTE:

The content of the CD may vary throughout the life cycle of the product and is subject to change without prior notice. Visit the IEI website or contact technical support for the latest updates.

The following drivers can be installed on the system:

- Chipset
- VGA
- LAN
- Audio
- Touch screen
- Wireless

Installation instructions are given below.

6.2 Starting the Driver Program

To access the driver installation programs, please do the following.

Step 1: Insert the CD-ROM that came with the system into a CD-ROM drive attached to the system.

Step 2: The list of drivers in **Figure 6-1** appears.



Figure 6-1: Drivers

6.3 Chipset Driver Installation

To install the chipset driver, please do the following.

Step 1: Access the driver list shown in **Figure 6-1** (See **Section 6.2**). Click “**Chipset**”.

Step 2: The setup files are extracted as shown in **Figure 6-2**.

AFL-xxA-N26 Series Panel PC



Figure 6-2: Chipset Driver Screen

Step 3: When the setup files are completely extracted the **Welcome Screen** in **Figure 6-3** appears.



Figure 6-3: Chipset Driver Welcome Screen

Step 4: Click **Next** to continue.

Step 5: The license agreement in **Figure 6-4** appears.

Step 6: Read the License Agreement.

Step 7: Click the **Yes** icon to continue.



Figure 6-4: Chipset Driver License Agreement

Step 8: The Read Me file in **Figure 6-5** appears.

Step 9: Click **Next** to continue.



Figure 6-5: Chipset Driver Read Me File

Step 10: Setup Operations are performed as shown in Figure 6-6.



Figure 6-6: Chipset Driver Setup Operations

Step 11: Once the **Setup Operations** are complete, click the **Next** icon to continue.

Step 12: The **Finish** screen appears.

Step 13: Select “**Yes, I want to restart the computer now**” and click the **Finish** icon.

See **Figure 6-7**.



Figure 6-7: Chipset Driver Installation Finish Screen

6.4 VGA Driver Installation

To install the VGA driver, please do the following.

Step 1: Access the driver list shown in **Figure 6-1** (See **Section 6.2**). Click “**VGA**”.

Step 2: The VGA Read Me file in **Figure 6-8** appears.

Step 3: Click **Next** to continue.

AFL-xxA-N26 Series Panel PC

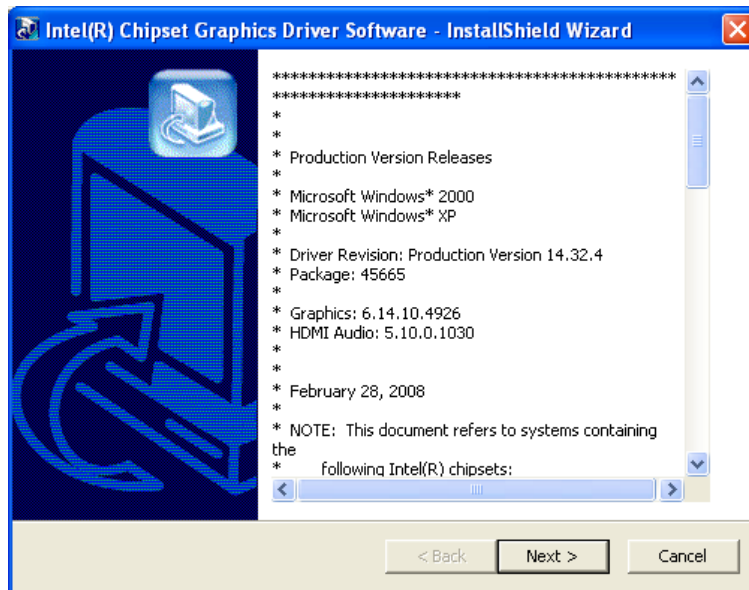

Figure 6-8: VGA Driver Read Me File

Step 4: The installation files are extracted. See **Figure 6-9**.

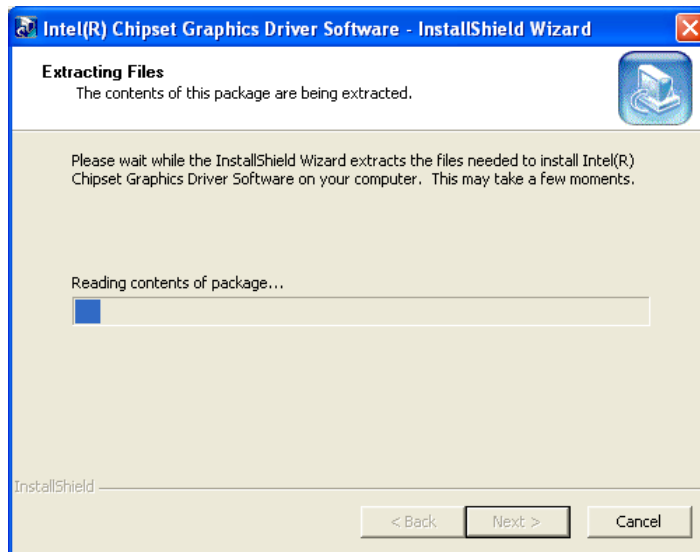

Figure 6-9: VGA Driver Setup Files Extracted

Step 5: The **Welcome Screen** in **Figure 6-10** appears.



Figure 6-10: VGA Driver Welcome Screen

- Step 6:** Click **Next** to continue.
- Step 7:** The license agreement in **Figure 6-11** appears.
- Step 8:** Read the **License Agreement**.
- Step 9:** Click the **Yes** icon to continue.

AFL-xxA-N26 Series Panel PC

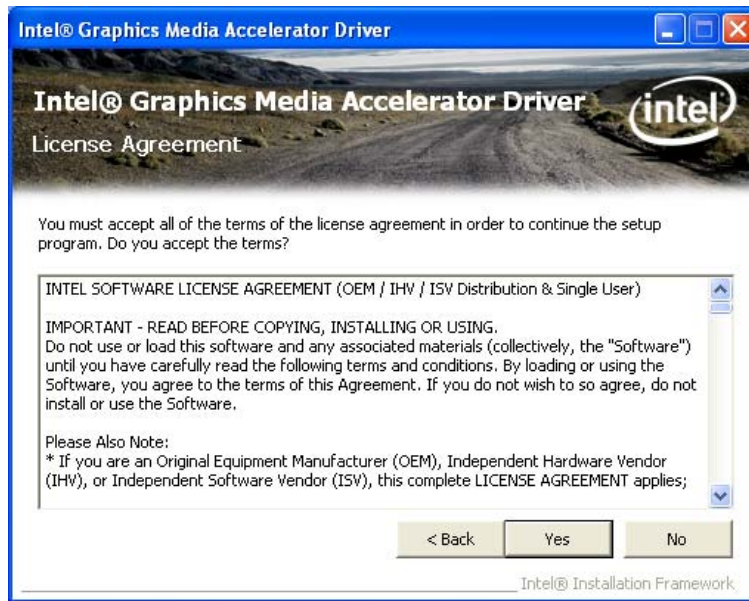

Figure 6-11: VGA Driver License Agreement

Step 10: The Read Me file in **Figure 6-12** appears.

Step 11: Click **Next** to continue.

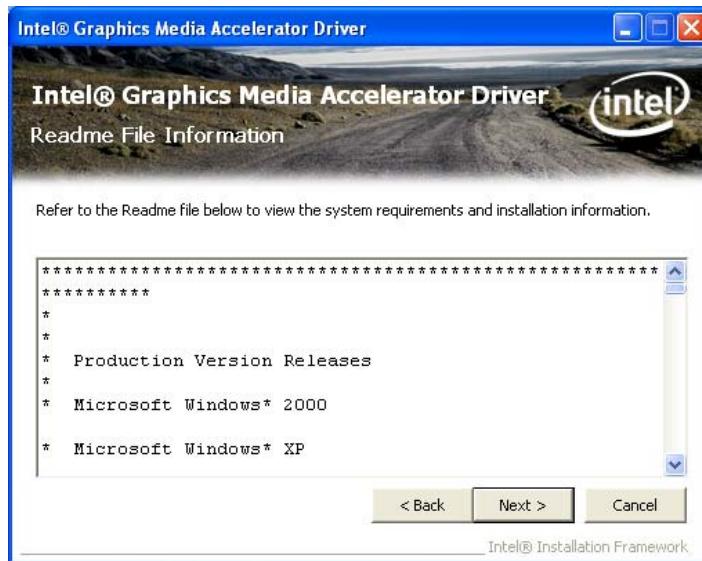

Figure 6-12: VGA Driver Read Me File

Step 12: Setup Operations are performed as shown in **Figure 6-13**.

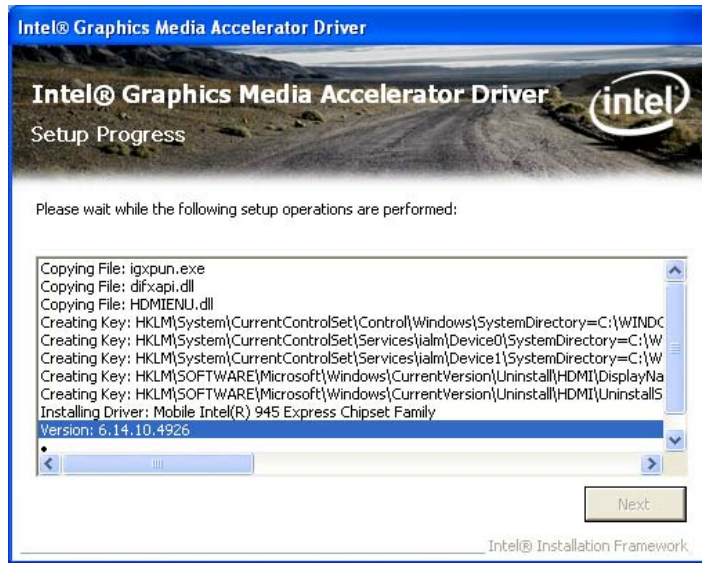

Figure 6-13: VGA Driver Setup Operations

Step 13: Once the **Setup Operations** are complete, click the **Next** icon to continue.

Step 14: The **Finish** screen appears.

Step 15: Select “**Yes, I want to restart the computer now**” and click the **Finish** icon.

See **Figure 6-14**.

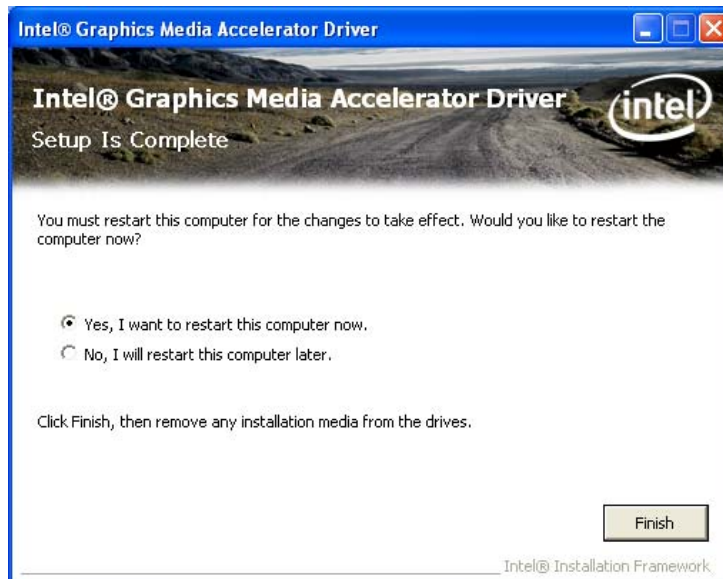

Figure 6-14: VGA Driver Installation Finish Screen

AFL-xxA-N26 Series Panel PC

6.5 LAN Driver Installation

To install the LAN driver, please do the following.

Step 1: Access the driver list shown in **Figure 6-1** (See **Section 6.2**). Click “LAN”.

Step 2: The **Welcome** screen in **Figure 6-15** appears.

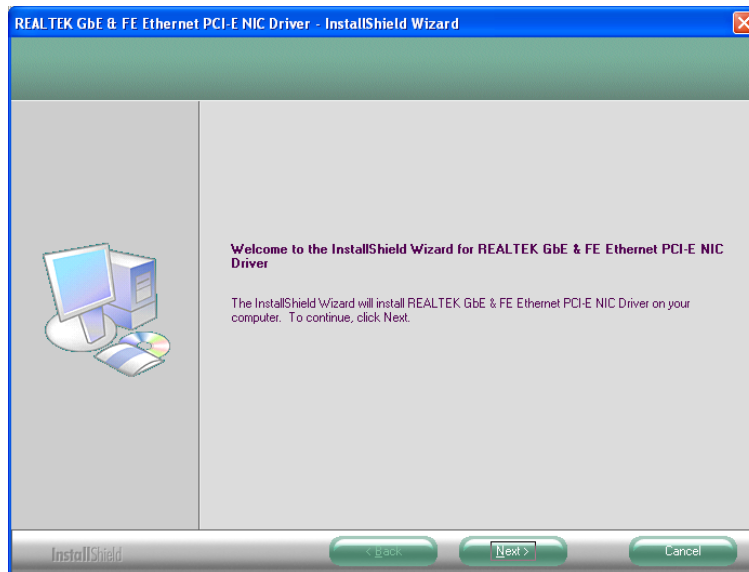

Figure 6-15: LAN Driver Welcome Screen

Step 3: Click **Next** to continue.

Step 4: The **Ready to Install** screen in **Figure 6-16** appears.

Step 5: Click **Next** to proceed with the installation.

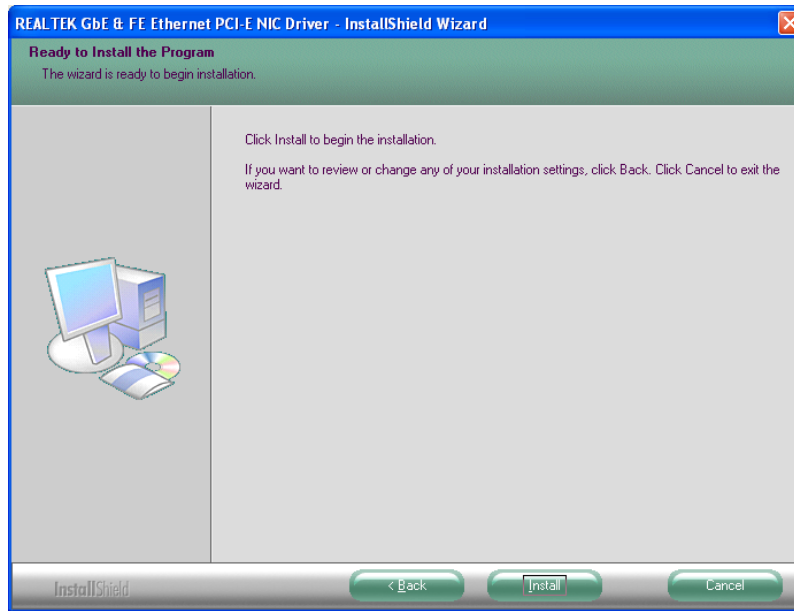

Figure 6-16: LAN Driver Welcome Screen

Step 6: The program begins to install.

Step 7: The installation progress can be monitored in the progress bar shown in **Figure 6-17**.

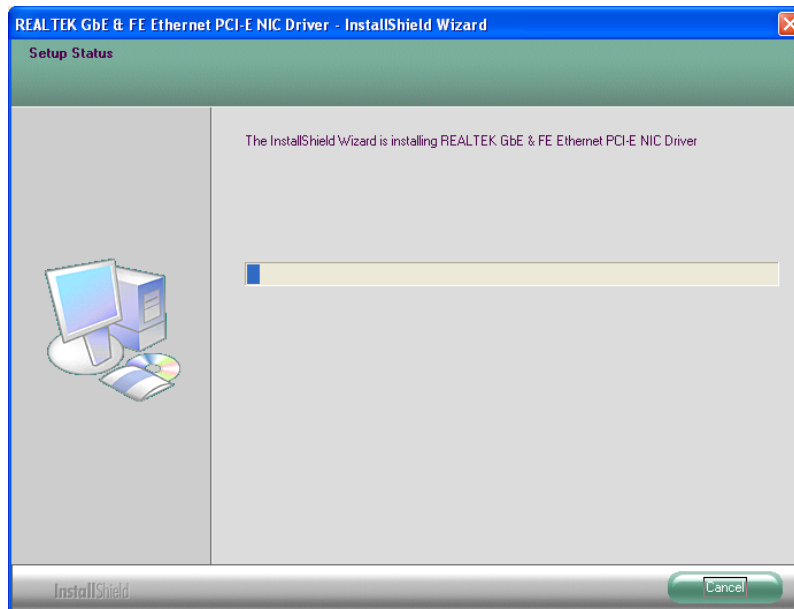

Figure 6-17: LAN Driver Installation

Step 8: When the driver installation is complete, the screen in **Figure 6-18** appears.

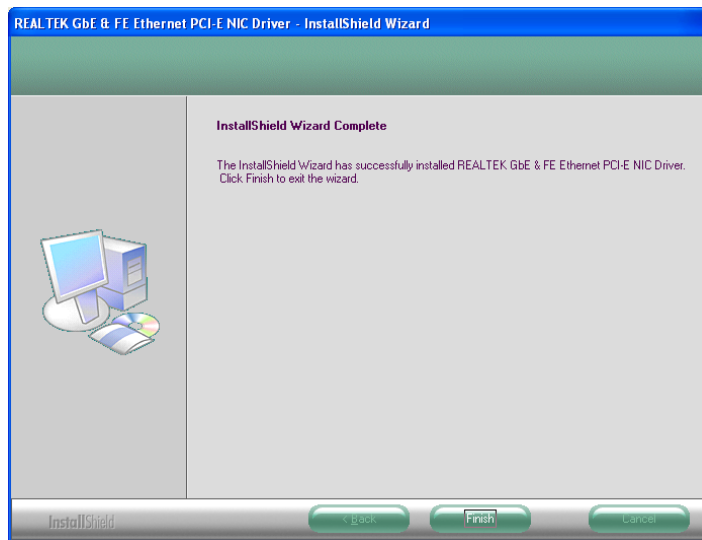

Figure 6-18: LAN Driver Installation Complete

6.6 Audio Driver Installation

To install the audio driver, please do the following.

- Step 1:** Access the driver list shown in **Figure 6-1** (See **Section 6.2**). Click **“Audio”**.
- Step 2:** Locate the setup file and double click it.
- Step 3:** The **InstallShield Wizard** starts (**Figure 6-19**).

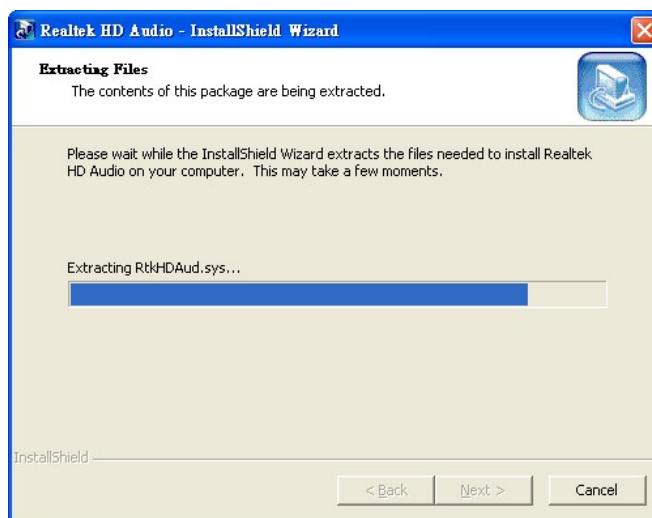

Figure 6-19: The InstallShield Wizard Starts

Step 4: The **InstallShield Wizard** is prepared to guide the user through the rest of the process (**Figure 6-20**).

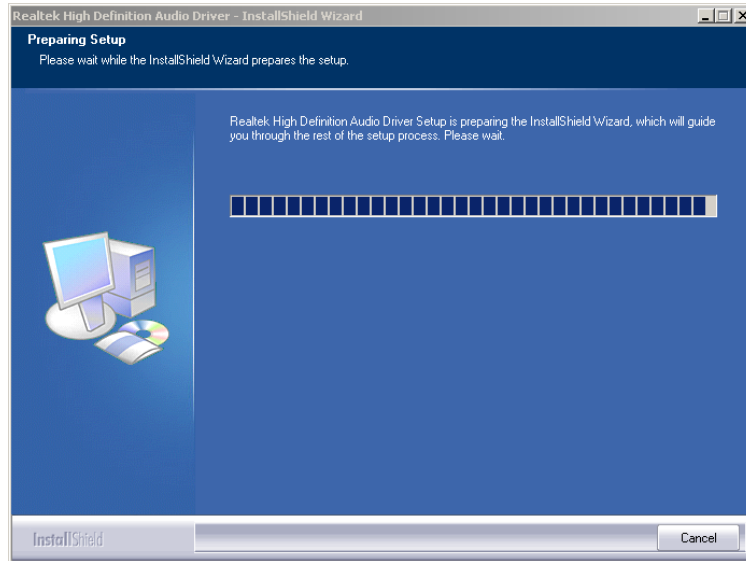

Figure 6-20: Preparing Setup Screen

Step 5: Once initialized, the **InstallShield Wizard** welcome screen appears (**Figure 6-21**).

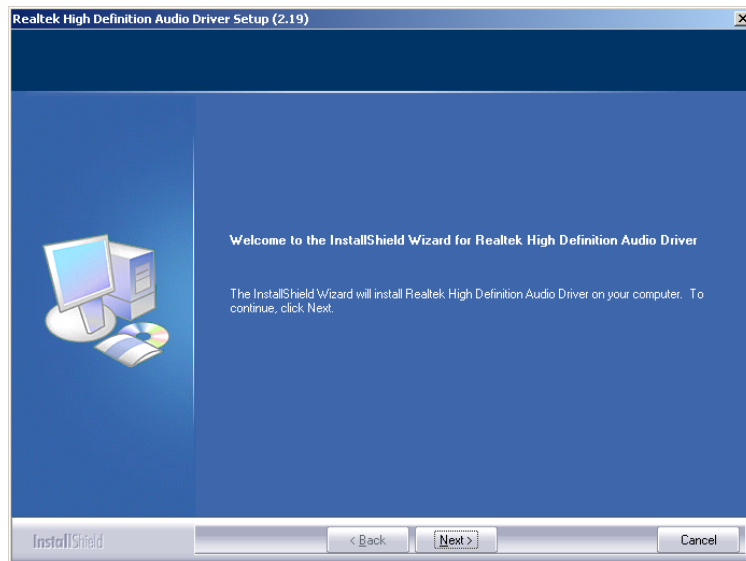

Figure 6-21: InstallShield Wizard Welcome Screen

Step 6: Click **NEXT** to continue the installation.

AFL-xxA-N26 Series Panel PC

Step 7: InstallShield starts to install the new software as shown in **Figure 6-22**.

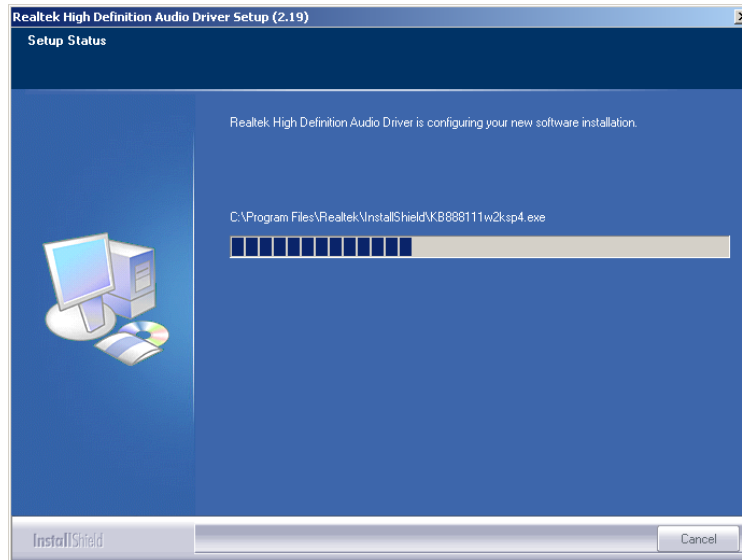

Figure 6-22: Audio Driver Software Configuration

Step 8: After the driver installation process is complete, a confirmation screen appears (**Figure 6-23**).

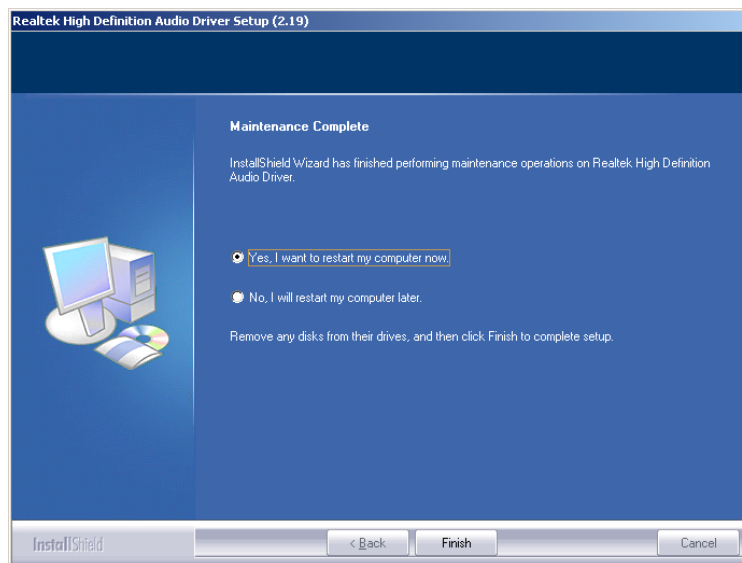

Figure 6-23: Restart the Computer

Step 9: The confirmation screen offers the option of restarting the computer now or later. For the settings to take effect, the computer must be restarted. Click **FINISH** to restart the computer.

6.7 Touch Screen Driver

To install the touch panel software driver, please follow the steps below.

Step 1: Access the driver list shown in **Figure 6-1** (See **Section 6.2**). Click “**Touch Screen**”.

Step 2: A welcome screen appears (**Figure 6-24**). To continue the installation process click **NEXT**.

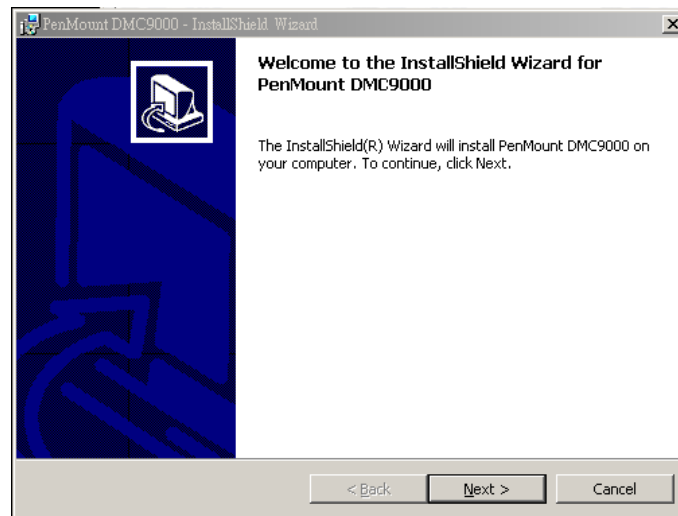

Figure 6-24: Welcome Screen

Step 3: The license agreement shown in **Figure 6-25** appears. Agree to the license by selecting “I accept the terms in the license agreement”.

AFL-xxA-N26 Series Panel PC

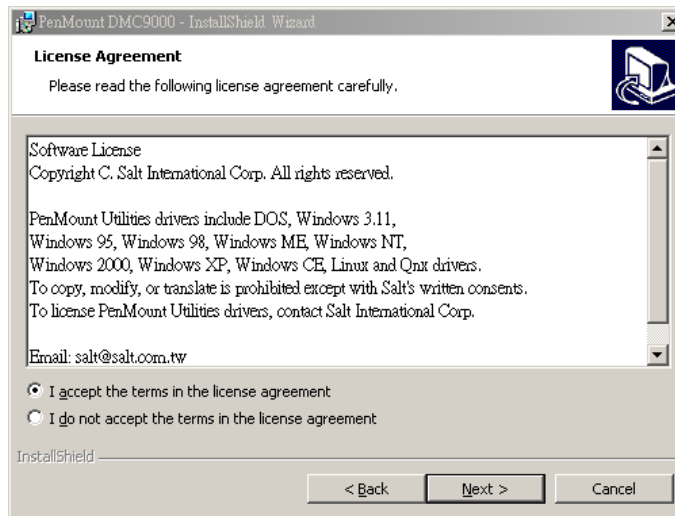

Figure 6-25: License Agreement

Step 4: Click **NEXT** and the Installshield Wizard is ready to install the program (Figure 6-26).

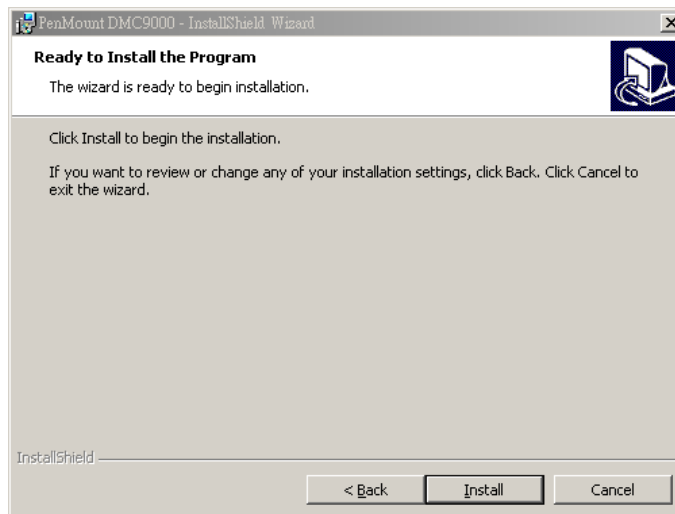

Figure 6-26: Ready to Install the Program

Step 5: Click **INSTALL** to continue. The Installing PenMount DMC9000 screen appears as the program is installed (Figure 6-27).

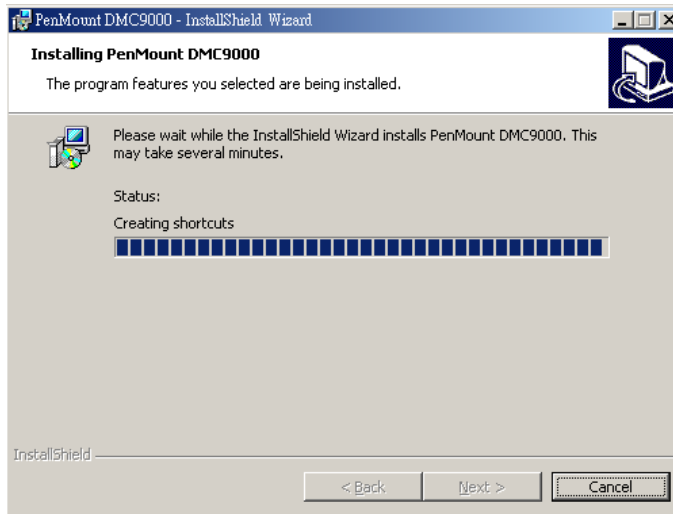

Figure 6-27: Installing PenMount DMC9000

Step 6: The user is then prompted to select to restart the computer now or later (Figure 6-28). For the settings to take effect, the computer must be restarted. Click **Yes** to restart the computer.

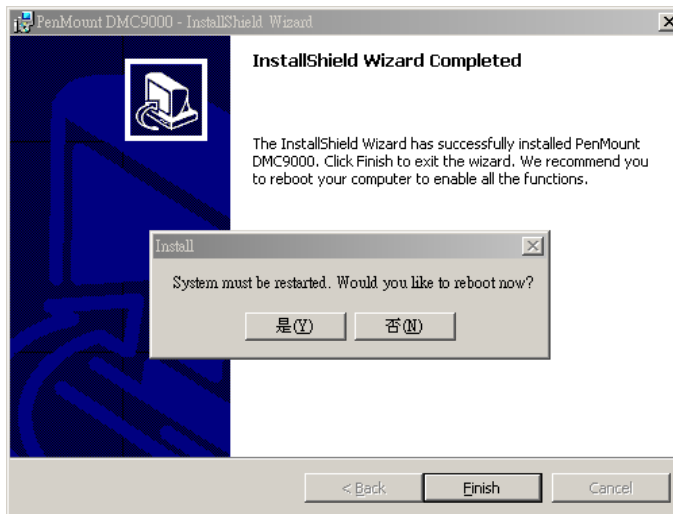

Figure 6-28: Reboot the Computer

6.8 Wireless Driver

To install the wireless driver, please follow the steps below.

Step 1: Select **Wireless** from the list in **Figure 6-1**.

AFL-xxA-N26 Series Panel PC

Step 2: A new window opens. Select the **RT5392** folder. Double click the .exe file to install the wireless LAN driver.

Step 3: The license agreement in **Figure 6-29** appears.

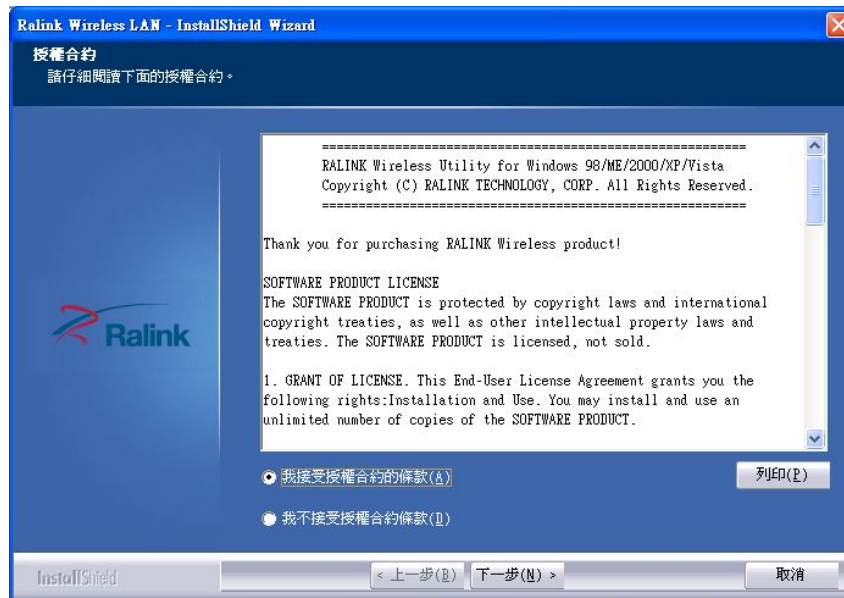

Figure 6-29: Wireless Driver License Agreement

Step 4: Accept the conditions of the license agreement and click **NEXT** to continue.

Step 5: The **Configuration Tool Options** screen in **Figure 6-30** appears next.



Figure 6-30: Wireless Driver Configuration Tool Options

Step 6: Select configuration tool in **Figure 6-30** and click **NEXT** to continue.

Step 7: The **Wireless Mode Options** window in **Figure 6-31** appears.



Figure 6-31: Wireless Mode Select Window

Step 8: Click **NEXT** in **Figure 6-31**.

Step 9: Click **INSTALL** in **Figure 6-32** to start to install the driver.

AFL-xxA-N26 Series Panel PC

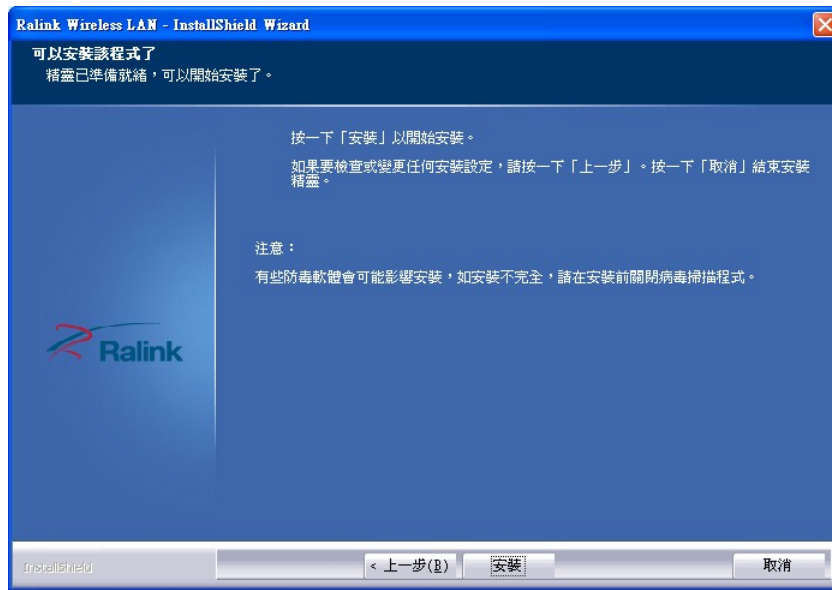

Figure 6-32: Wireless Driver Installation

Step 10: When the installation is finished. Click **FINISH** in the termination screen.



Chapter

7

Interface Connectors

AFL-xxA-N26 Series Panel PC

7.1 Peripheral Interface Connectors

The AFL-xxA-N26 series panel PC motherboard comes with a number of peripheral interface connectors and configuration jumpers. The connector locations are shown in **Figure 7-1** and **Figure 7-2**. The Pin 1 locations of the on-board connectors are also indicated in the diagrams below. The connector pinouts for these connectors are listed in the following sections.

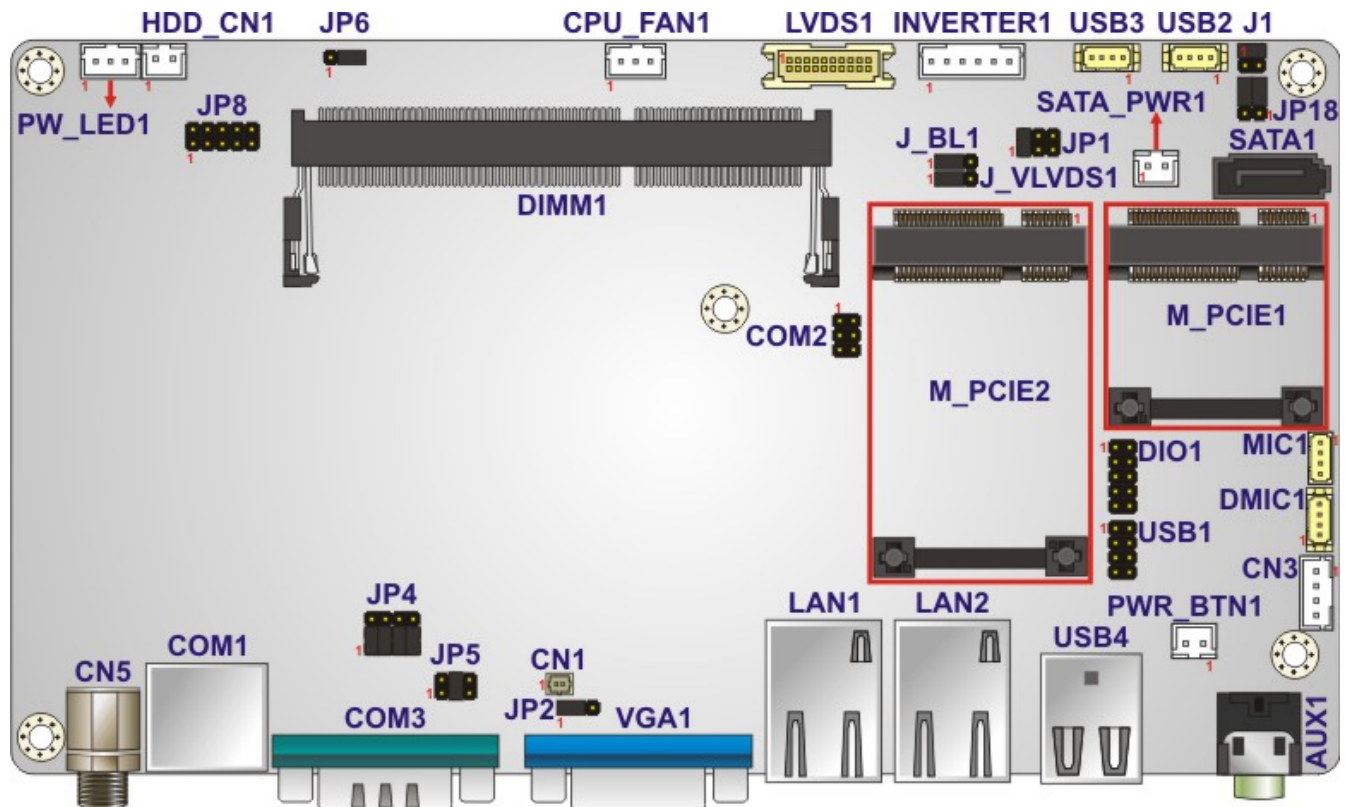

Figure 7-1: Main Board Layout Diagram (Front Side)

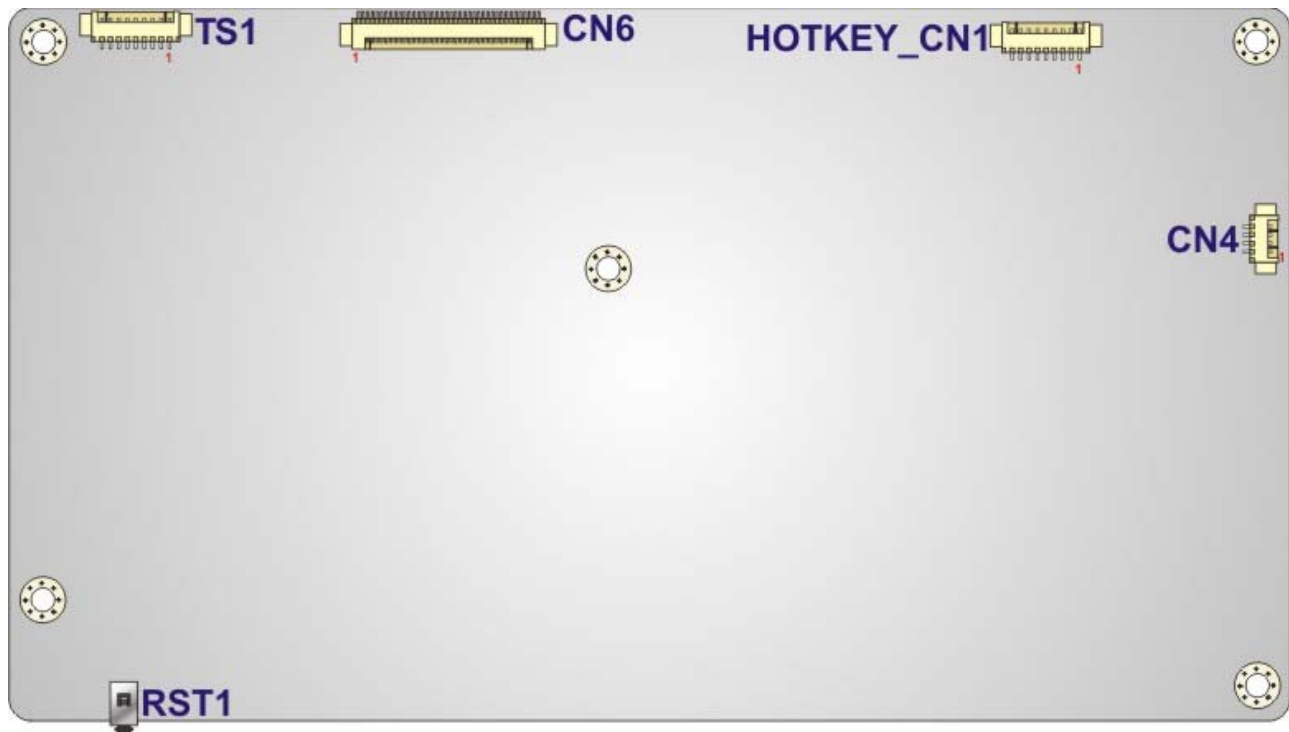

Figure 7-2: Main Board Layout Diagram (Solder Side)

7.2 Internal Peripheral Connectors

Internal peripheral connectors are found on the motherboard and are only accessible when the motherboard is outside of the chassis. The table below shows a list of the peripheral interface connectors on the AFL-xxA-N26 motherboard. Pinouts of these connectors can be found in the following sections.

Connector	Type	Label
Audio speaker connector	4-pin wafer	CN3
Audio MIC-in connector	4-pin wafer	MIC1
Audio DMIC-in connector	4-pin wafer	DMIC1
Battery connector	2-pin wafer	CN11
COM2 connector	6-pin header	COM2
CPU fan connector	3-pin wafer	CPU_FAN1
DIO connector	10-pin header	DIO1

AFL-xxA-N26 Series Panel PC

Connector	Type	Label
HDD LED connector	2-pin wafer	HDD_CN1
I2C connector (solder side)	4-pin wafer	CN4
LVDS connector	20-pin crimp	LVDS1
LVDS backlight connector	6-pin wafer	INVERTER1
MCU connector (solder side)	9-pin wafer	HOTKEY_CN1
MCU connector	10-pin header	JP8
PCIe Mini card slots	PCIe Mini card slot	M_PCIE1 M_PCIE2
Power LED connector	3-pin wafer	PW_LED1
Power button connector	2-pin wafer	PW_BTN1
SATA power connector	2-pin wafer	SATA_PWR1
SATA connector	SATA connector	SATA1
SO-DIMM connector	SO-DIMM connector	DIMM1
Touch panel connector (solder side)	9-pin wafer	TS1
TTL panel connector (solder side)	40-pin FPC connector	CN6
USB connector	8-pin header	USB1
USB connector	4-pin wafer	USB2
USB connector	4-pin wafer	USB4
USB2 and USB3 power connector	6-pin header	JP18

Table 7-1: Peripheral Interface Connectors

7.2.1 Audio Speaker-out Connector (CN3)

PIN NO.	DESCRIPTION
1	AUD_OUTL+
2	AUD_OUTL-
3	AUD_OUTR-
4	AUD_OUTR+

Table 7-2: Audio Line-out Connector (CN3) Pinouts

7.2.2 Audio MIC-in Connector (MIC1)

PIN NO.	DESCRIPTION
1	MIC1_IN_L
2	AGND_AMP
3	MIC_JD
4	MIC1_IN_R

Table 7-3: Audio MIC-in Connector (MIC1) Pinouts

7.2.3 Audio DMIC-in Connector (DMIC1)

PIN NO.	DESCRIPTION
1	DMIC_CLK
2	DMIC_DATA
3	+3.3V
4	GND

Table 7-4: Audio DMIC-in Connector (DMIC1) Pinouts

AFL-xxA-N26 Series Panel PC

7.2.4 Battery Connector (CN1)

PIN NO.	DESCRIPTION
1	Battery +3.3V
2	GND

Table 7-5: Battery Connector (CN1) Pinouts

7.2.5 COM2 Connector (COM2)

PIN NO.	DESCRIPTION	PIN NO.	DESCRIPTION
1	+5V	2	RX2
3	N/A	4	TX2
5	GND	6	RFID_INT

Table 7-6: COM2 Connector Pinouts

7.2.6 CPU Fan Connector (CPU_FAN1)

PIN NO.	DESCRIPTION
1	FANIN1_CPU +5V _{sus}
2	VCC +12V
3	GND

Table 7-7: CPU Fan Connector (CPU_FAN1) Pinouts

7.2.7 DIO Connector (DIO1)

PIN NO.	DESCRIPTION	PIN NO.	DESCRIPTION
1	GND	2	VCC_+5V
3	DGPO3	4	DGPO2
5	DGPO1	6	DGPO0
7	DGPI3	8	DGPI2
9	DGPI1	10	DGPI0

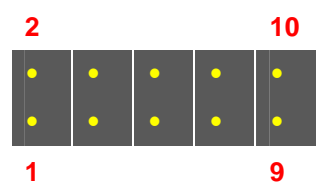

Table 7-8: DIO Connector (DIO1) Pinouts

7.2.8 HDD LED Connector (HDD_CN1)

PIN NO.	DESCRIPTION
1	+5V
2	HD_LED

Table 7-9: HDD LED Connector (HDD_CN1) Pinouts

7.2.9 I2C Connector (CN4)

PIN NO.	DESCRIPTION
1	GND
2	SMBDATA
3	SMBCLK
4	+5V

Table 7-10: I2C Connector (CN4) Pinouts

7.2.10 LVDS Connector (LVDS1)

PIN NO.	DESCRIPTION	PIN NO.	DESCRIPTION
1	GND	2	GND
3	LVDSA0+	4	LVDSA0-
5	LVDSA1+	6	LVDSA1-
7	LVDSA2+	8	LVDSA2-
9	LVDSACLK+	10	LVDSACLK-
11	LVDSA3+	12	LVDSA3-
13	GND	14	GND
15	NC	16	NC
17	VCCLCD	18	VCCLCD
19	VCCLCD	20	VCCLCD

Table 7-11: LVDS Connector (LVDS1) Pinouts

7.2.11 LVDS Backlight Connector (INVERTER1)

PIN NO.	DESCRIPTION
1	+12V
2	+12V
3	BLON
4	BRIGHTNESS
5	GND
6	GND

Table 7-12: LVDS Backlight Connector (INVERTER1) Pinouts

7.2.12 MCU Connector (JP8)

PIN NO.	DESCRIPTION	PIN NO.	DESCRIPTION
1	MCLR	2	+5V
3	+5V	4	MCU_IR
5	ICSPCLK	6	AUTO_CLK
7	ICSPDAT	8	AUTO_DATA
9	GND	10	GND

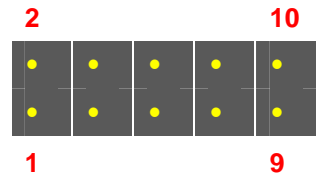

Table 7-13: MCU Connector (JP8) Pinouts

7.2.13 MCU Connector (HOTKEY_CN1)

PIN NO.	DESCRIPTION
1	AUTO_DIMMING
2	LOCK_BUTTON
3	VOL+
4	VOL-
5	BRIGHT+
6	BRIGHT-
7	LCD_ON_OFF
8	GND

Table 7-14: MCU Connector (HOTKEY_CN1) Pinouts

7.2.14 PCIe Mini Slot (M_PCIE1)

PIN NO.	DESCRIPTION	PIN NO.	DESCRIPTION
1	WAKE#	2	VCC3
3	RESERVED	4	GND
5	RESERVED	6	VCC1.5
7	CLKREQ#	8	N/C
9	GND	10	N/C
11	REFCLK0-	12	N/C
13	REFCLK0+	14	N/C
15	GND	16	N/C
17	N/C	18	GND
19	N/C	20	N/C
21	GND	22	PERST#
23	PERn3	24	VCC3_AUX
25	PERp3	26	GND
27	GND	28	VCC1.5
29	GND	30	SMB_CLK
31	PETn3	32	SMB_DATA
33	PETp3	34	GND
35	GND	36	USB6_DATA-
37	RESERVED	38	USB6_DATA+
39	RESERVED	40	GND
41	RESERVED	42	LED_WWAN#
43	RESERVED	44	LED_WLAN#
45	RESERVED	46	LED_WPAN#
47	RESERVED	48	VCC1.5
49	RESERVED	50	GND
51	RESERVED	52	VCC3

Table 7-15: PCIe Mini Card Slot (M_PCIE1) Pinouts

7.2.15 PCIe Mini Slot (M_PCIE2)

PIN NO.	DESCRIPTION	PIN NO.	DESCRIPTION
1	WAKE#	2	VCC3
3	RESERVED	4	GND
5	RESERVED	6	VCC1.5
7	CLKREQ#	8	N/C
9	GND	10	N/C
11	REFCLK1-	12	N/C
13	REFCLK1+	14	N/C
15	GND	16	N/C
17	N/C	18	GND
19	N/C	20	N/C
21	GND	22	PERST#
23	PERn0	24	VCC3_AUX
25	PERp0	26	GND
27	GND	28	VCC1.5
29	GND	30	SMB_CLK
31	PETn0	32	SMB_DATA
33	PETp0	34	GND
35	GND	36	USB7_DATA-
37	RESERVED	38	USB7_DATA+
39	RESERVED	40	GND
41	RESERVED	42	LED_WWAN#
43	RESERVED	44	LED_WLAN#
45	RESERVED	46	LED_WPAN#
47	RESERVED	48	VCC1.5
49	RESERVED	50	GND
51	RESERVED	52	VCC3

Table 7-16: PCIe Mini Card Slot (M_PCIE2) Pinouts

7.2.16 Power LED Connector (PW_LED1)

PIN NO.	DESCRIPTION
1	PW_LED +5V
2	GND
3	SUS PW LED +5V

Table 7-17: Power LED Connector (PW_LED1) Pinouts

7.2.17 Power Button Connector (PW_BTN1)

PIN NO.	DESCRIPTION
1	PW_BN
2	GND

Table 7-18: Power Button Connector (PW_BTN1) Pinouts

7.2.18 SATA Power Connector (SATA_PWR1)

PIN NO.	DESCRIPTION
1	+5V
2	GND

Table 7-19: SATA Power Connector (SATA_PWR1) Pinouts

7.2.19 SATA Connector (SATA1)

PIN NO.	DESCRIPTION
1	GND
2	STXP_0
3	STXN_0
4	GND
5	SRXN_0
6	SRXP_0
7	GND

Table 7-20: SATA Connector (SATA1) Pinouts

7.2.20 Touch Panel Connector (TS1)

PIN NO.	8-Wire	4-Wire	5-Wire
1	Right Sense	N/A	N/A
2	Left Sense	N/A	N/A
3	Bottom Sense	N/A	N/A
4	Top Sense	N/A	Sense (S)
5	Right Excite	Right	LR (X)
6	Left Excite	Left	LL (L)
7	Bottom Excite	Bottom	UR (H)
8	Top Excite	Top	UL (Y)
9	GND	GND	GND

Table 7-21: Touch Panel Connector (TS1) Pinouts

7.2.21 TTL Panel Connector (CN6)

PIN NO.	DESCRIPTION	PIN NO.	DESCRIPTION
1	GND	21	TFT_G5
2	GND	22	TFT_G4
3	TTL_VSYNC	23	TFT_G3
4	TTL_VCC3	24	GND
5	TTL_VCC3	25	TFT_G2
6	TTL_VCC3	26	TFT_G1
7	TTL_VCC3	27	TFT_G0
8	TTL_HSYNC	28	GND
9	LCD_EN	29	TFT_R5
10	GND	30	TFT_R4
11	GND	31	TFT_R3
12	GND	32	GND
13	TFT_B5	33	TFT_R2
14	TFT_B4	34	TFT_R1
15	TFT_B3	35	TFT_R0
16	GND	36	GND

17	TFT_B2	37	GND
18	TFT_B1	38	DOTCLK
19	TFT_B0	39	GND
20	GND	40	GND

Table 7-22: TTL Panel Connector (CN6) Pinouts

7.2.22 USB Connector (USB1)

PIN NO.	DESCRIPTION	PIN NO.	DESCRIPTION
1	+5V _{sus}	2	GND
3	D0F-	4	D1F+
5	D0F+	6	D1F-
7	GND	8	+5V _{sus}

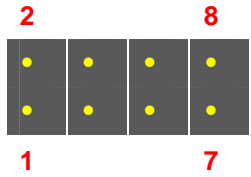
Table 7-23: USB Connector (USB1) Pinouts

7.2.23 USB Connector (USB2)

PIN NO.	DESCRIPTION
1	+5V _{sus}
2	D2F-
3	D2F+
4	GND

Table 7-24: USB Connector (USB2) Pinouts

AFL-xxA-N26 Series Panel PC

7.2.24 USB Connector (USB3)

PIN NO.	DESCRIPTION
1	+5V _{sus}
2	D3F-
3	D3F+
4	GND

Table 7-25: USB Connector (USB3) Pinouts

7.2.25 USB2 and USB3 Power Connector (JP18)

PIN NO.	DESCRIPTION	PIN NO.	DESCRIPTION
1	+3.3V	2	+3.3V
3	GND	4	GND
5	+5V	6	+5V

Table 7-26: USB2 and USB3 Power Connector (JP18) Pinouts

7.3 External Interface Panel Connectors

The table below lists the rear panel connectors on the AFL-xxA-N26 motherboard. Pinouts of these connectors can be found in the following sections.

Connector	Type	Label
Audio line-out connector	Audio jack	AUX1
Ethernet connector	RJ-45	LAN1, LAN2
Power connector	Power jack	CN5
Reset button	Push button	RST1
RS-232 serial ports	RJ-45	COM1
RS-232/422/485 serial port	DB-9	COM3
USB 2.0 connectors	USB 2.0 port	USB3
VGA connector	DB-15	VGA1

Table 7-27: Rear Panel Connectors

7.3.1 Audio Line-out Connector (AUX1)

PIN NO.	DESCRIPTION
1	GND
2	OUTL
3	AMP_INL
4	AMP_INR
5	OUTR

Table 7-28: Audio Line-in Connector (AUX1) Pinouts

7.3.2 Ethernet Connector (LAN1, LAN2)

PIN NO.	DESCRIPTION	PIN NO.	DESCRIPTION
1	LAN1_MDIO+	2	LAN1_MDIO-
3	LAN1_MDI1+	4	LAN1_MDI1-
5	N/A	6	N/A
7	LAN1_MDI2+	8	LAN1_MDI2-
9	LAN1_MDI3+	10	LAN1_MDI3-
11	+3.3Vsus	12	ACT-1
13	LAN1_LINK1000 +3.3Vsus	14	LAN1_LINK100 +3.3Vsus
15	GND	16	GND
17	N/A	18	N/A

Table 7-29: Ethernet Connector (LAN1, LAN2) Pinouts

7.3.3 Power Connector (CN5)

PIN NO.	DESCRIPTION
1	VCC12_IN
2	GND
3	GND

Table 7-30: Power Connector (CN5) Pinouts

AFL-xxA-N26 Series Panel PC

7.3.4 RS-232 Serial Port (COM1, RJ-45)

PIN NO.	DESCRIPTION	PIN NO.	DESCRIPTION
1	NDCD1	5	NTX1
2	NDSR1	6	NCTS1
3	NRX1	7	NDTR1
4	NRTS1	8	NRI1

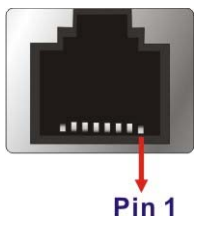

Table 7-31: RS-232 Serial Port (COM1) Pinouts

7.3.5 RS-232/422/485 Serial Port (COM3/COM4, DB-9)

PIN NO.	DESCRIPTION	PIN NO.	DESCRIPTION
1	NDCDB	6	NDSRB
2	NRXDB	7	NRTSB
3	NTX3	8	NCTS3
4	NDTR3	9	COM_RI3
5	GND	10	GND

Table 7-32: RS-232 Serial Port (COM3, DB-9) Pinouts

PIN NO.	RS-422 Description
1	TX-
2	TX+
6	RX-
7	RX+

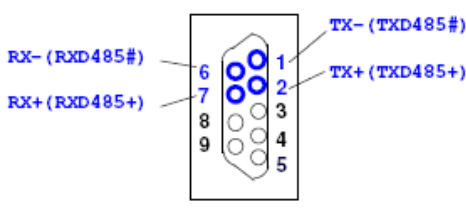

Table 7-33: RS-422 Serial Port (COM4, DB-9) Pinouts

PIN NO.	RS-485 Description
1	Data-
2	Data+

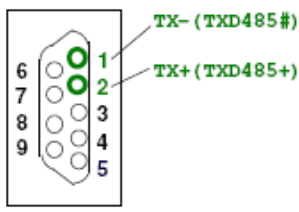

Table 7-34: RS-485 Serial Port (COM4, DB-9) Pinouts

7.3.6 Reset Button Connector (RST1)

PIN NO.	DESCRIPTION
1	RST_SW
2	GND
3	GND
4	GND

Table 7-35: Reset Button Connector (RST1) Pinouts

7.3.7 USB 2.0 Connectors (USB4)

PIN NO.	DESCRIPTION	PIN NO.	DESCRIPTION
1	+5V _{sus}	5	+5V _{sus}
2	D4F-	6	D5F-
3	D4F+	7	D5F+
4	GND	8	GND

Table 7-36: USB 2.0 Connectors (USB4) Pinouts

7.3.8 VGA Connector (VGA1)

PIN NO.	DESCRIPTION	PIN NO.	DESCRIPTION
1	RED	2	GREEN
3	BLUE	4	N/A
5	GND	6	CRT_PLUG
7	GND	8	GND
9	+5V	10	GND
11	N/A	12	DDCDA
13	HSYNC	14	VSYNC
15	DDCLK		

Table 7-37: VGA Connector (VGA1) Pinouts

7.4 Preconfigured Jumper Settings

The following jumpers are preconfigured for the AFL-xxA-N26. Users should not change these jumpers (Table 7-38). It is only for reference.

Jumper Name	Label	Type
Backlight voltage selection	J_BL1	3-pin header
Inverter ADJ power selection	JP6	3-pin header
Inverter power selection	JP1	6-pin header
LVDS voltage selection	J_VLVDS1	3-pin header
Touchscreen selection	J1	4-pin header

Table 7-38: Preconfigured Jumpers

7.4.1 Backlight Voltage Selection Jumper (J_BL1)

Pin	Description
Short 1-2	+3.3 V (Default)
Short 2-3	+5 V

Table 7-39: Backlight Voltage Selection Jumper (J_BL1) Settings

7.4.2 Inverter ADJ Power Selection Jumper (JP6)

Pin	Description
Short 1-2	+5 V
Short 2-3	+3.3 V (Default)

Table 7-40: Inverter ADJ Power Selection Jumper (JP6) Settings

7.4.3 Inverter Power Selection Jumper (JP1)

Pin	Description
Short 1-2	+12 V (Default)
Short 3-4	+5 V
Short 5-6	+3.3 V

Table 7-41: Inverter Power Selection Jumper (JP1) Settings

7.4.4 LVDS Panel Voltage Selection Jumper (J_VLVDS1)

Pin	Description
Short 1-2	+3.3 V (Default)
Short 2-3	+5 V

Table 7-42: LVDS Voltage Selection Jumper (J_VLVDS1) Settings

7.4.5 Touchscreen Selection Jumper (J1)

Pin	Description
Short 1-2	5-wire (Default)
Short 3-4	4-wire

Table 7-43: Touchscreen Selection Jumper (J1) Settings

Appendix

A

Safety Precautions

WARNING:

The precautions outlined in this chapter should be strictly followed. Failure to follow these precautions may result in permanent damage to the AFOLUX AFL-xxA-N26 series.

A.1 Safety Precautions

Please follow the safety precautions outlined in the sections that follow:

A.1.1 General Safety Precautions

Please ensure the following safety precautions are adhered to at all times.

- **Follow the electrostatic precautions** outlined below whenever the AFOLUX AFL-xxA-N26 series is opened.
- **Make sure the power is turned off and the power cord is disconnected** whenever the AFOLUX AFL-xxA-N26 series is being installed, moved or modified.
- **Do not apply voltage levels that exceed the specified voltage range.** Doing so may cause fire and/or an electrical shock.
- **Electric shocks can occur** if the AFOLUX AFL-xxA-N26 series chassis is opened when the AFOLUX AFL-xxA-N26 series is running.
- **Do not drop or insert any objects** into the ventilation openings of the AFOLUX AFL-xxA-N26 series.
- **If considerable amounts of dust, water, or fluids enter the AFOLUX AFL-xxA-N26 series**, turn off the power supply immediately, unplug the power cord, and contact the AFOLUX AFL-xxA-N26series vendor.
- **DO NOT:**
 - Drop the AFOLUX AFL-xxA-N26 series against a hard surface.
 - Strike or exert excessive force onto the LCD panel.
 - Touch any of the LCD panels with a sharp object
 - In a site where the ambient temperature exceeds the rated temperature

AFL-xxA-N26 Series Panel PC

A.1.2 Anti-static Precautions



WARNING:

Failure to take ESD precautions during the installation of the AFOLUX AFL-xxA-N26 series may result in permanent damage to the AFOLUX AFL-xxA-N26 series and severe injury to the user.

Electrostatic discharge (ESD) can cause serious damage to electronic components, including the AFOLUX AFL-xxA-N26 series. Dry climates are especially susceptible to ESD. It is therefore critical that whenever the AFOLUX AFL-xxA-N26 series is opened and any of the electrical components are handled, the following anti-static precautions are strictly adhered to.

- ***Wear an anti-static wristband:*** Wearing a simple anti-static wristband can help to prevent ESD from damaging any electrical component.
- ***Self-grounding:*** Before handling any electrical component, touch any grounded conducting material. During the time the electrical component is handled, frequently touch any conducting materials that are connected to the ground.
- ***Use an anti-static pad:*** When configuring or working with an electrical component, place it on an anti-static pad. This reduces the possibility of ESD damage.
- ***Only handle the edges of the electrical component:*** When handling the electrical component, hold the electrical component by its edges.

A.1.3 Product Disposal



CAUTION:

Risk of explosion if battery is replaced by and incorrect type. Only certified engineers should replace the on-board battery.

Dispose of used batteries according to instructions and local regulations.

- Outside the European Union - If you wish to dispose of used electrical and electronic products outside the European Union, please contact your local authority so as to comply with the correct disposal method.
- Within the European Union:

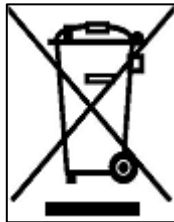

EU-wide legislation, as implemented in each Member State, requires that waste electrical and electronic products carrying the mark (left) must be disposed of separately from normal household waste. This includes monitors and electrical accessories, such as signal cables or power cords.

When you need to dispose of your display products, please follow the guidance of your local authority, or ask the shop where you purchased the product. The mark on electrical and electronic products only applies to the current European Union Member States.

Please follow the national guidelines for electrical and electronic product disposal.

A.2 Maintenance and Cleaning Precautions

When maintaining or cleaning the AFOLUX AFL-xxA-N26 series, please follow the guidelines below.

A.2.1 Maintenance and Cleaning

Prior to cleaning any part or component of the AFOLUX AFL-xxA-N26 series, please read the details below.

AFL-xxA-N26 Series Panel PC

- Except for the LCD panel, never spray or squirt liquids directly onto any other components. To clean the LCD panel, gently wipe it with a piece of soft dry cloth or a slightly moistened cloth.
- The interior of the AFOLUX AFL-xxA-N26X series does not require cleaning. Keep fluids away from the AFOLUX AFL-xxA-N26 series interior.
- Be cautious of all small removable components when vacuuming the AFOLUX AFL-xxA-N26 series.
- Turn the AFOLUX AFL-xxA-N26 series off before cleaning the AFOLUX AFL-xxA-N26 series.
- Never drop any objects or liquids through the openings of the AFOLUX AFL-xxA-N26 series.
- Be cautious of any possible allergic reactions to solvents or chemicals used when cleaning the AFOLUX AFL-xxA-N26 series.
- Avoid eating, drinking and smoking within vicinity of the AFOLUX AFL-xxA-N26 series.

A.2.2 Cleaning Tools

Some components in the AFOLUX AFL-xxA-N26 series may only be cleaned using a product specifically designed for the purpose. In such case, the product will be explicitly mentioned in the cleaning tips. Below is a list of items to use when cleaning the AFOLUX AFL-xxA-N26 series.

- **Cloth** – Although paper towels or tissues can be used, a soft, clean piece of cloth is recommended when cleaning the AFOLUX AFL-xxA-N26 series.
- **Water or rubbing alcohol** – A cloth moistened with water or rubbing alcohol can be used to clean the AFOLUX AFL-xxA-N26 series.
- **Using solvents** – The use of solvents is not recommended when cleaning the AFOLUX AFL-xxA-N26 series as they may damage the plastic parts.
- **Vacuum cleaner** – Using a vacuum specifically designed for computers is one of the best methods of cleaning the AFOLUX AFL-xxA-N26 series. Dust and dirt can restrict the airflow in the AFOLUX AFL-xxA-N26 series and cause its circuitry to corrode.
- **Cotton swabs** - Cotton swabs moistened with rubbing alcohol or water are excellent tools for wiping hard to reach areas.



- **Foam swabs** - Whenever possible, it is best to use lint free swabs such as foam swabs for cleaning.

Appendix

B

BIOS Configuration Options

B.1 BIOS Configuration Options

Below is a list of BIOS configuration options described in **Chapter 5**.

BIOS Information	71
System Date [xx/xx/xx]	71
System Time [xx:xx:xx]	72
ACPI Sleep State [S1 (CPU Stop Clock)]	74
Wake System with Fixed Time [Disabled]	75
Hyper-threading [Enabled]	77
Configure SATA as [IDE]	77
USB Devices	78
Legacy USB Support [Enabled]	78
Serial Port [Enabled]	80
Change Settings [Auto]	80
Serial Port [Enabled]	81
Change Settings [Auto]	81
Serial Port [Enabled]	82
Change Settings [Auto]	82
Hardware Health Status	83
CPU_FAN1 Smart Fan control [Auto Duty-Cycle Mode]	84
CPU Temperature n	84
SYS_FAN1 Smart Fan control [Auto Duty-Cycle Mode]	84
System Temperature n	85
Console Redirection [Disabled]	85
Auto Recovery Function [Disabled]	86
Fixed Graphics Memory Size [128MB]	89
Restore AC Power Loss [Last State]	89
Power Saving Function [Disabled]	90
Set Spread Spectrum fuction [Disabled]	90
Bootup NumLock State [On]	91
Quiet Boot [Enabled]	92
Launch PXE OpROM [Disabled]	92
Option ROM Messages [Force BIOS]	92
UEFI Boot [Disabled]	92

AFL-xxA-N26 Series Panel PC

Administrator Password	93
User Password	93
Save Changes and Reset	94
Discard Changes and Reset	94
Restore Defaults	94
Save as User Defaults	95
Restore User Defaults	95

Appendix

C

Watchdog Timer



NOTE:

The following discussion applies to DOS environment. IEI support is contacted or the IEI website visited for specific drivers for more sophisticated operating systems, e.g., Windows and Linux.

The Watchdog Timer is provided to ensure that standalone systems can always recover from catastrophic conditions that cause the CPU to crash. This condition may have occurred by external EMI or a software bug. When the CPU stops working correctly, Watchdog Timer either performs a hardware reset (cold boot) or a Non-Maskable Interrupt (NMI) to bring the system back to a known state.

A BIOS function call (INT 15H) is used to control the Watchdog Timer:

INT 15H:

AH – 6FH Sub-function:	
AL – 2:	Sets the Watchdog Timer's period.
BL:	Time-out value (Its unit-second is dependent on the item "Watchdog Timer unit select" in CMOS setup).

Table C-1: AH-6FH Sub-function

Call sub-function 2 to set the time-out period of Watchdog Timer first. If the time-out value is not zero, the Watchdog Timer starts counting down. While the timer value reaches zero, the system resets. To ensure that this reset condition does not occur, calling sub-function 2 must periodically refresh the Watchdog Timer. However, the Watchdog timer is disabled if the time-out value is set to zero.

A tolerance of at least 10% must be maintained to avoid unknown routines within the operating system (DOS), such as disk I/O that can be very time-consuming.

**NOTE:**

When exiting a program it is necessary to disable the Watchdog Timer, otherwise the system resets.

Example program:

```
; INITIAL TIMER PERIOD COUNTER
;
W_LOOP:

    MOV     AX, 6F02H      ;setting the time-out value
    MOV     BX, 05        ;time-out value is 5 seconds
    INT     15H

;
; ADD THE APPLICATION PROGRAM HERE
;

    CMP     EXIT_AP, 1     ;is the application over?
    JNE     W_LOOP        ;No, restart the application

    MOV     AX, 6F02H     ;disable Watchdog Timer
    MOV     BX, 0         ;
    INT     15H

;
; EXIT ;
```

Appendix

D

Hazardous Materials Disclosure

D.1 Hazardous Material Disclosure Table for IPB Products Certified as RoHS Compliant Under 2002/95/EC Without Mercury

The details provided in this appendix are to ensure that the product is compliant with the Peoples Republic of China (China) RoHS standards. The table below acknowledges the presences of small quantities of certain materials in the product, and is applicable to China RoHS only.

A label will be placed on each product to indicate the estimated “Environmentally Friendly Use Period” (EFUP). This is an estimate of the number of years that these substances would “not leak out or undergo abrupt change.” This product may contain replaceable sub-assemblies/components which have a shorter EFUP such as batteries and lamps. These components will be separately marked.

Please refer to the table on the next page.

AFL-xxA-N26 Series Panel PC

Part Name	Toxic or Hazardous Substances and Elements					
	Lead (Pb)	Mercury (Hg)	Cadmium (Cd)	Hexavalent Chromium (CR(VI))	Polybrominated Biphenyls (PBB)	Polybrominated Diphenyl Ethers (PBDE)
Housing	X	O	O	O	O	X
Display	X	O	O	O	O	X
Printed Circuit Board	X	O	O	O	O	X
Metal Fasteners	X	O	O	O	O	O
Cable Assembly	X	O	O	O	O	X
Fan Assembly	X	O	O	O	O	X
Power Supply Assemblies	X	O	O	O	O	X
Battery	O	O	O	O	O	O

O: This toxic or hazardous substance is contained in all of the homogeneous materials for the part is below the limit requirement in SJ/T11363-2006

X: This toxic or hazardous substance is contained in at least one of the homogeneous materials for this part is above the limit requirement in SJ/T11363-2006

此附件旨在确保本产品符合中国 RoHS 标准。以下表格标示此产品中某有毒物质的含量符合中国 RoHS 标准规定的限量要求。

本产品上会附有“环境友好使用期限”的标签，此期限是估算这些物质“不会有泄漏或突变”的年限。本产品可能包含有较短的环境友好使用期限的可替换元件，像是电池或灯管，这些元件将会单独标示出来。

部件名称	有毒有害物质或元素					
	铅 (Pb)	汞 (Hg)	镉 (Cd)	六价铬 (CR(VI))	多溴联苯 (PBB)	多溴二苯醚 (PBDE)
壳体	X	O	O	O	O	X
显示	X	O	O	O	O	X
印刷电路板	X	O	O	O	O	X
金属螺帽	X	O	O	O	O	O
电缆组装	X	O	O	O	O	X
风扇组装	X	O	O	O	O	X
电力供应组装	X	O	O	O	O	X
电池	O	O	O	O	O	O

O: 表示该有毒有害物质在该部件所有物质材料中的含量均在 SJ/T11363-2006 标准规定的限量要求以下。

X: 表示该有毒有害物质至少在该部件的某一均质材料中的含量超出 SJ/T11363-2006 标准规定的限量要求。