

# **MEC-DIS-271L**

**M.2 2280 (B+M key) LVDS output display board**

---

## **User's Manual**

**First Edition, January 2024**



© 2024 Cervo Technology Co., Ltd. All rights reserved.

Reproduction without permission is prohibited

# M.2 2280 Display Card

## User's Manual

The software described in this manual is furnished under a license agreement and may be used only in accordance with the terms of that agreement.

### Copyright Notice

© 2024 Cervoz Technology Co., Ltd. All rights reserved. Reproduction without permission is prohibited.

### Trademarks

Cervoz is a registered trademark of Cervoz Technology Co., Ltd. All other trademarks or registered marks in this manual belong to their respective manufacturers.

### Disclaimer

Information in this document is subject to change without notice and does not represent a commitment on the part of Cervoz.

Cervoz provides this document "as is," without warranty of any kind, either expressed or implied, including, but not limited to, its particular purpose. Cervoz reserves the right to make improvements and/or changes to this manual, or to the products and/or the programs described in this manual, at any time.

Information provided in this manual is intended to be accurate and reliable. However, Cervoz assumes no responsibility for its use, or for any infringements on the rights of third parties that may result from its use.

This product might include unintentional technical or typographical errors. Changes are periodically made to the information herein to correct such errors, and these changes are incorporated into new editions of the publication.

### Technical Support Contact Information

<http://www.cervoz.com/support/technical.php>

### Cervoz Technology Co., Ltd.

Tel: +886-2-2911-9599

Fax: +886-2-2911-9566

# Table of Contents

<b>Chapter 1</b>	<b>Introduction</b>	4
	Overviews	4
	Features	4
	Installation Flowchart	5
	Package Checklist	5
<b>Chapter 2</b>	<b>Hardware Installation</b>	6
<b>Chapter 3</b>	<b>Software Installation</b>	8
<b>Appendix</b>	<b>Pin Assignments</b>	13
	Board Side Pin Assignments	13
	<b>Technical Reference</b>	15
	MEC-DIS-271L Specifications	15
	MEC-DIS-271LS Dimensions	16
	MEC-DIS-271LW Dimensions	16
	<b>Product Warranty Statement</b>	17

# 1

## Introduction

---

### Overview

MEC-DIS-271L is a LVDS output display card for embedded PC. The card follows the M.2 standard which is compliant with PCI Express x 2 classification and M.2 form factor. This board fits in any host computer that has M.2 slots.

### Features

The PCI Express boards have the following outstanding features:

- Dual-Lane (x2) PCI-Express with throughput to 5.0/2.5 GT/s
- Fully compliant with PCI-Express Base Specification Rev.2.0
- Support 24 or 48 bit LVDS Channel
- Built in 256MB DDR3 memory
- 128-bit high performance graphics engine
- LVDS display resolution up to 1920x1080@60Hz
- Support 3.3V or 5V panel power select by switch setting

# Installation Flowchart

## Installation Flowchart of MEC-DIS-271L

The following flowchart provides a brief summary of the procedure you should follow to install the M.2 card:

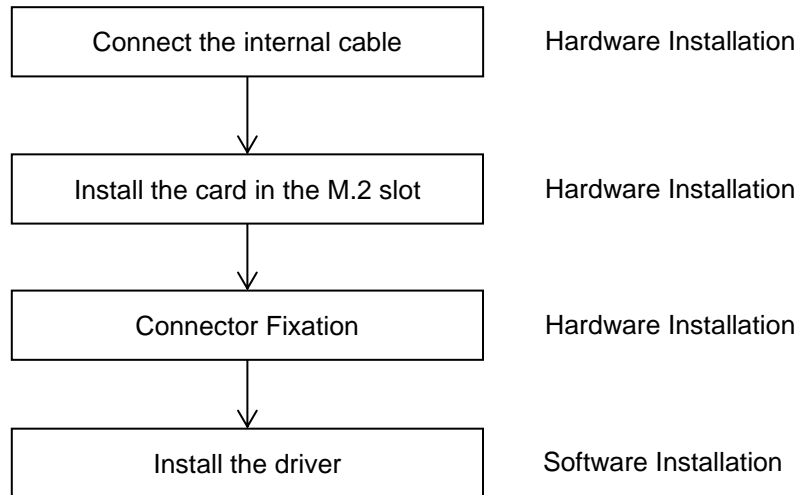

## Package Checklist

The following items are included in the M.2 board package:

### MEC-DIS-271LS

- M.2 2280 Card x 1
- 4Pin Power Input Cable (30cm) x 1
- Quick Installation Guide (Printed) x 1

### MEC-DIS-271LW

- M.2 2280 Card (with Heatsink) x 1
- 4Pin Power Input Cable (30cm) x 1
- Quick Installation Guide (Printed) x 1

*Note: Notify your sales representative if any of the above items are missing or damaged.*

# 2

## Hardware Installation

---

This chapter describes the PCI Express Series hardware installation procedure. Since the BIOS automatically assign the PCI Express board's IRQ number and I/O addresses, you must plug in the board before installing the driver.

### Step 1 Connect the internal cable to the card

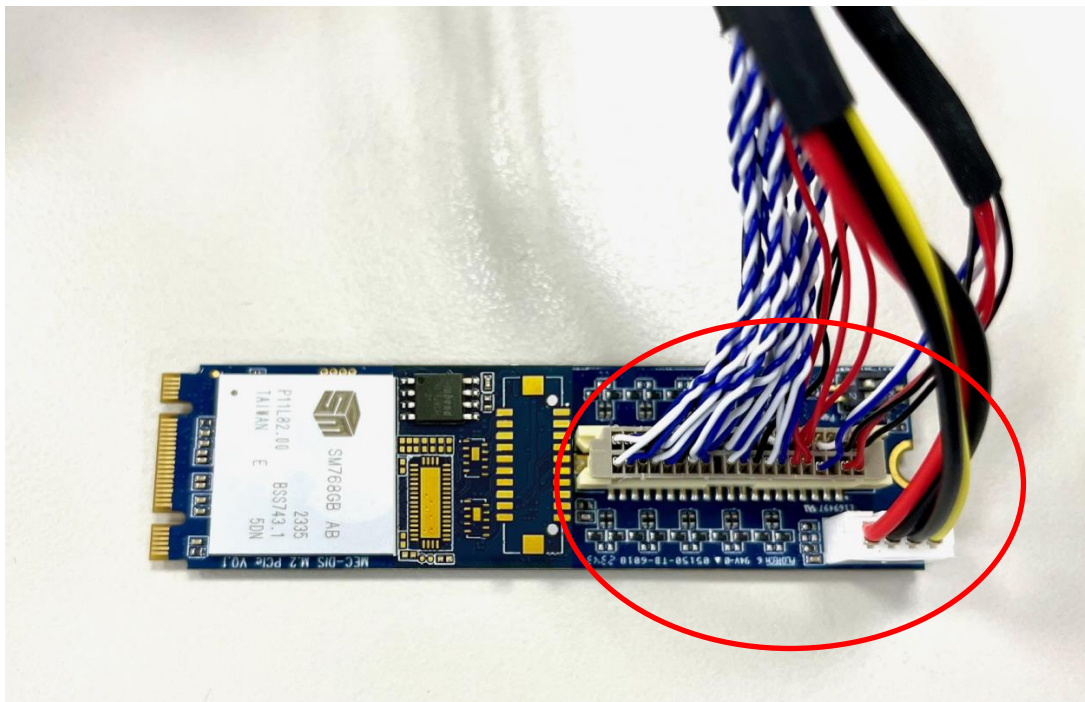

LVDS cable is not included

**Step 2**

**Install the card to the M.2 slot**



Make sure you install the card in the right position (fool-proof design)

**Step 3**

**Fix the card on the motherboard**



# 3

## Driver Installation

---

This chapter describes the procedures of installation, configuration and update/removal the driver on Windows 10.

### Step 1 Turn on PC and start Windows



Please download driver from Cervoz website.

1. To ensure the installation of hardware device.

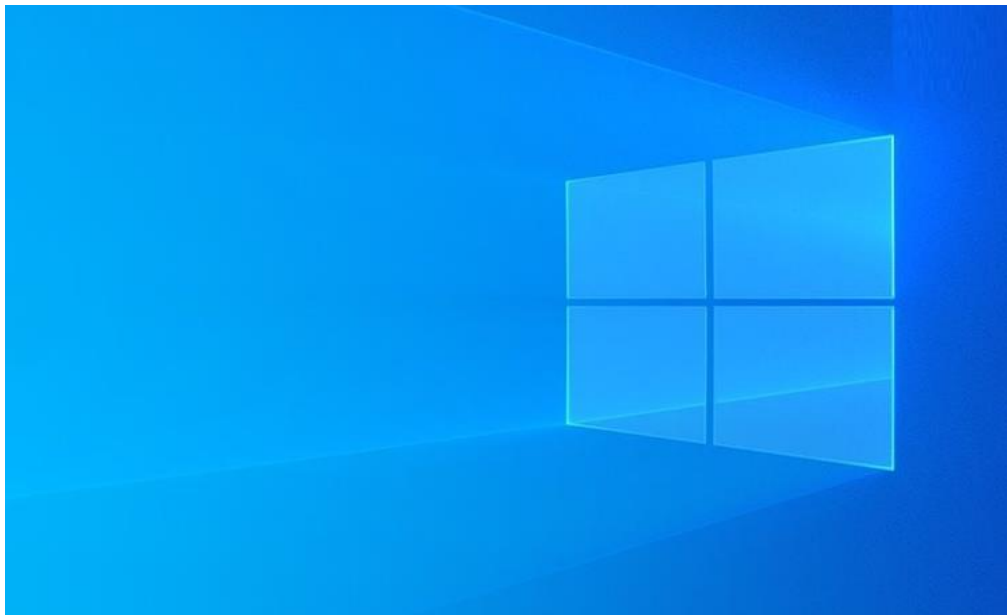

**Note** Win 10 OS as example



In order to provide the correct driver and firmware, please provide panel model before purchasing



## Step 2 Find the “SM768 PCIE Win10” folder

Open the “SM768 PCIE Win10” folder and run the “setup” file.

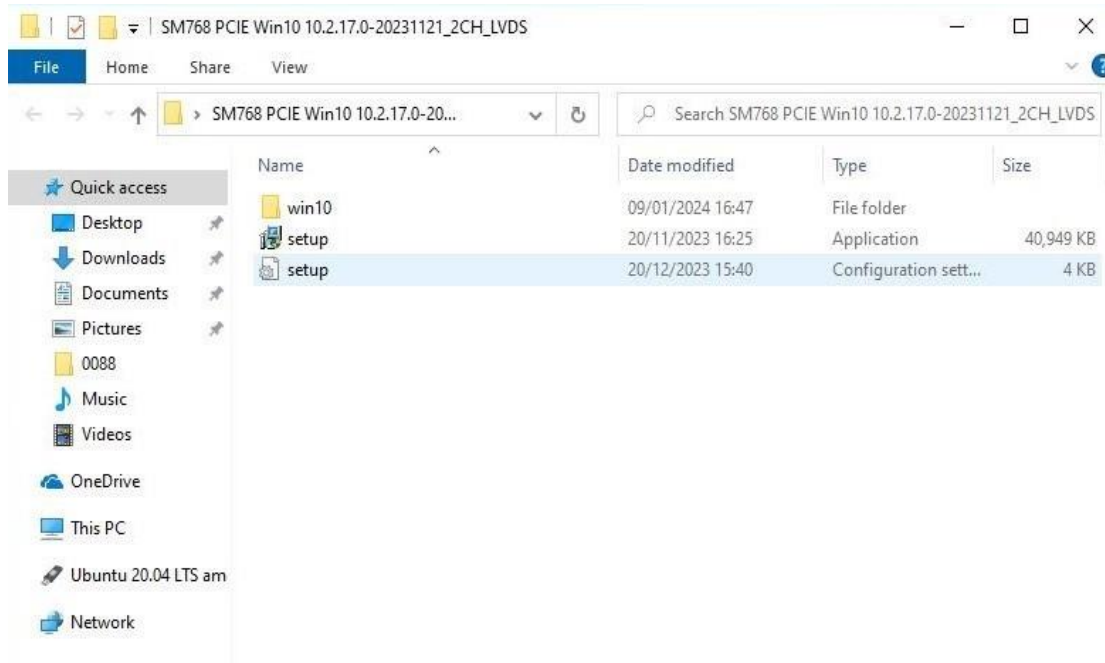

## Step 3 Driver installation set up

Click “Next”



## Step 4 Driver installation set up

Select "I accept the agreement" and click "Next"

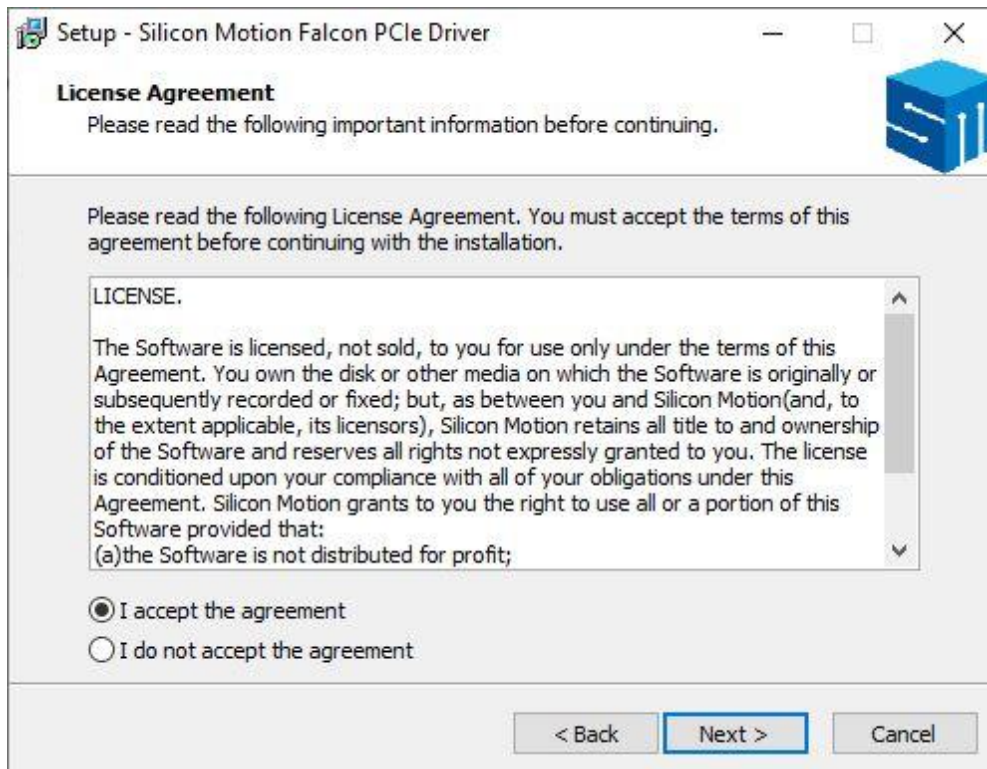

## Step 5 Installation in progress

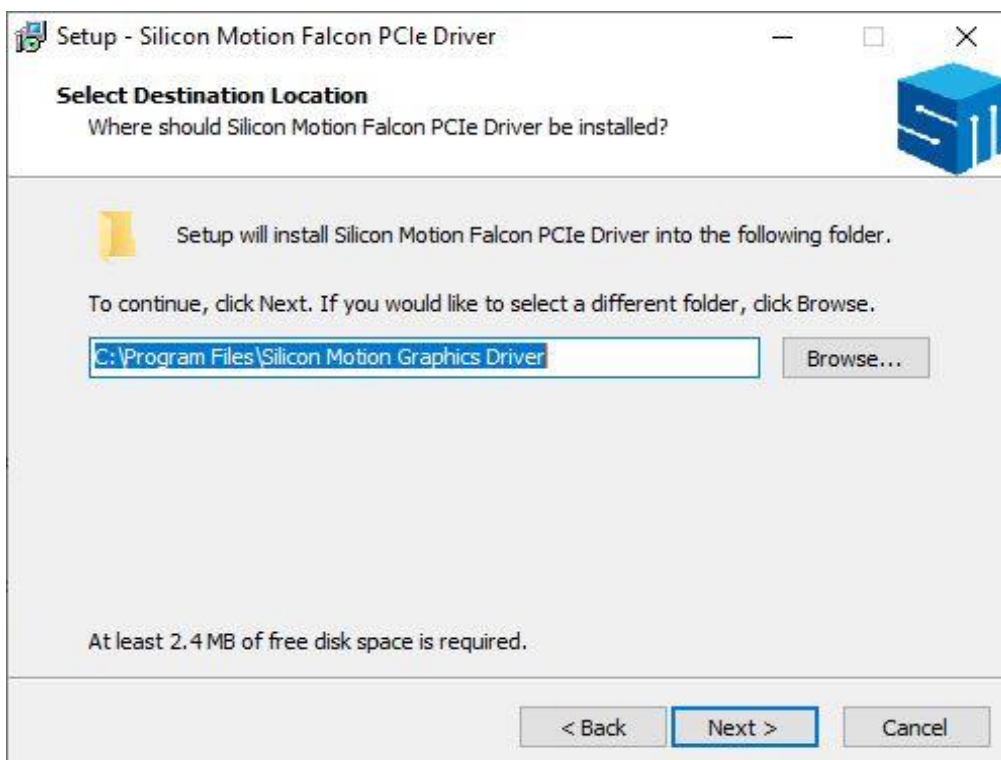

**Step 6**

**Driver installation completed, restart PC**

Select “Yes, restart the computer now” and click “Finish”



## Step 7 Confirm if driver is ready to be used

1. Start "Computer Management" program
2. Go to the route:  
*My Computer* → *Manage* → *Device Manager* → *Display adaptors*
3. You would find the driver names: SiliconMotion SM768 WDDM2.0 Display Driver
4. Device is ready to be used

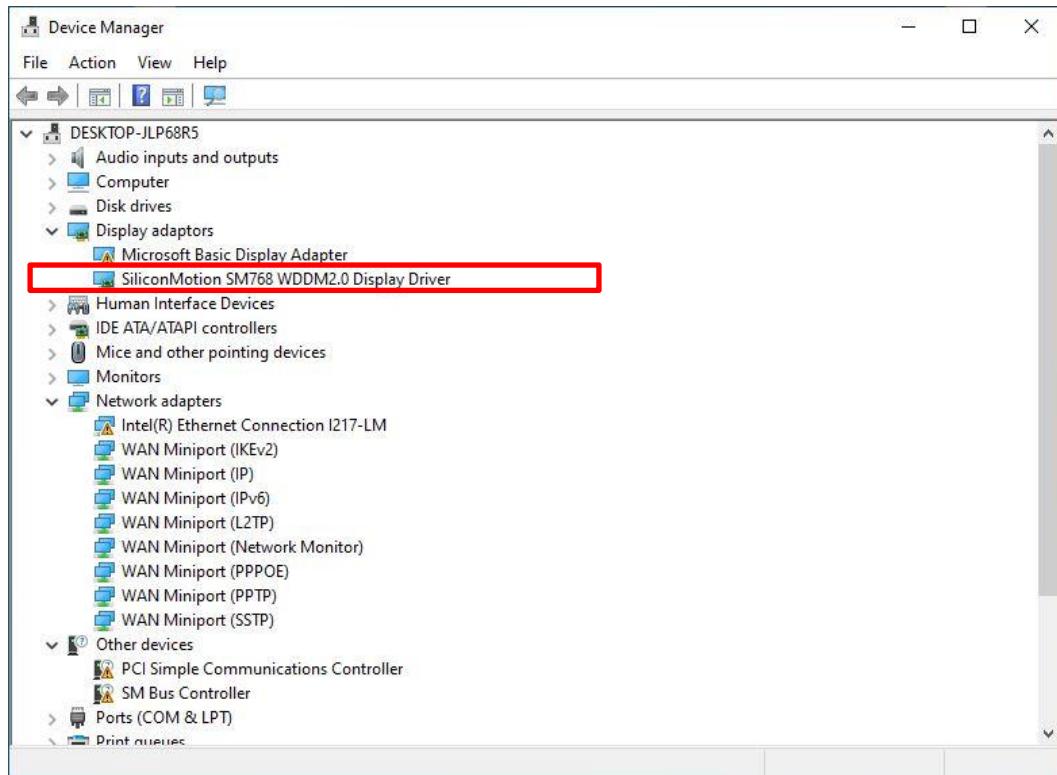

# Appendix

## □ Pin Assignments

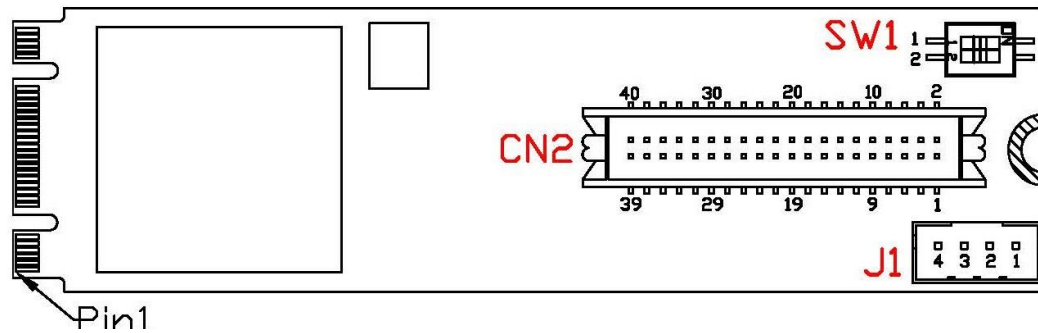

### SW1

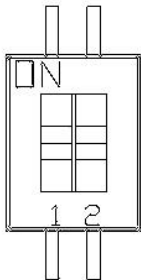

	Function	ON	OFF(Default)
Switch 1	External/ Internal Panel Power select	External Power	Internal Power
Switch 2	Internal Panel Power 3.3V/5V select	5V	3.3V

(Only when switch 1=OFF, switch 2 function can be used)

### J1

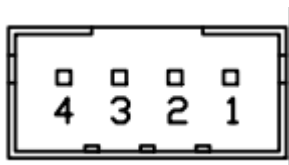

PIN	Function
1	Backlight Power(12V)
2	GND
3	GND
4	External Panel Power(5V)

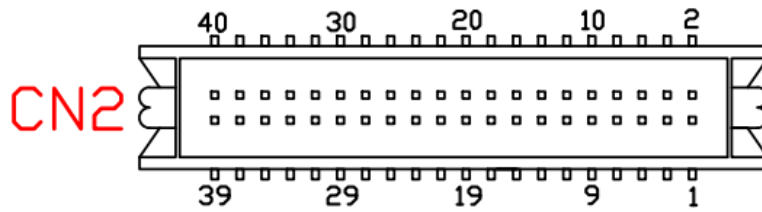

Pin	Function	Pin	Function
1	Backlight Power(12V)	21	A2+
2	Backlight GND	22	A3-
3	Backlight Power(12V)	23	GND
4	Backlight GND	24	GND
5	Backlight Power(12V)	25	A4-
6	Backlight GND	26	CLK1+
7	Panel Enable	27	A4+
8	Backlight PWM Dimming	28	CLK1-
9	Panel VDD	29	GND
10	Panel VDD	30	GND
11	Panel VDD	31	A5-
12	5V_OUT	32	A6+
13	A0-	33	A5+
14	A1+	34	A6-
15	A0+	35	GND
16	A1-	36	GND
17	GND	37	A7-
18	GND	38	CLK2+
19	A2-	39	A7+
20	A3+	40	CLK2-

# □ Technical Reference

## MEC-DIS-271L Specifications

### General

PCI-Express Revision	PCI-Express Base Specification Rev 2.0
PCI-Express Electromechanical Revision	PCI-Express M.2 Electromechanical Rev. 1.1

### Hardware

Controllers	SMI SM768
Bus	Dual-Lane (x2) PCI-Express with throughput up to 5.0/2.5 GT/s

### Interface (Connector)

LVDS	X1(Single/Dual Channel LVDS)
------	------------------------------

### Performance

LVDS Resolution	24/48bit LVDS
-----------------	---------------

### Driver Support

Operating Systems	Win 7, Win 10, Linux
-------------------	----------------------

### Power Requirement

Power Consumption	850mA@3.3V
-------------------	------------

### Dimensions

Width x Length (mm)	22.00 x 80.00
---------------------	---------------

### Environmental Limits

Operating Temperature	MEC-DIS-271LS: 0°C ~ 70°C MEC-DIS-271LW: -40°C ~ 85°C
Storage Temperature	-40°C ~ 95°C
Humidity	5% ~ 95%

### Regulatory Approvals

EMC	CE, FCC, UKCA
EMI	EN 55032, EN61000-3-2, EN61000-3-3, FCC Part 15 Subpart B Class B
EMS	EN 55035, IEC 61000-4-2, IEC 61000-4-3, IEC 61000-4-4, IEC 61000-4-5, IEC 61000-4-6, IEC 61000-4-8, IEC 61000-4-11

### Reliability

Warranty	3 years
MTBF	>20,161,919

## MEC-DIS-271LS Dimensions

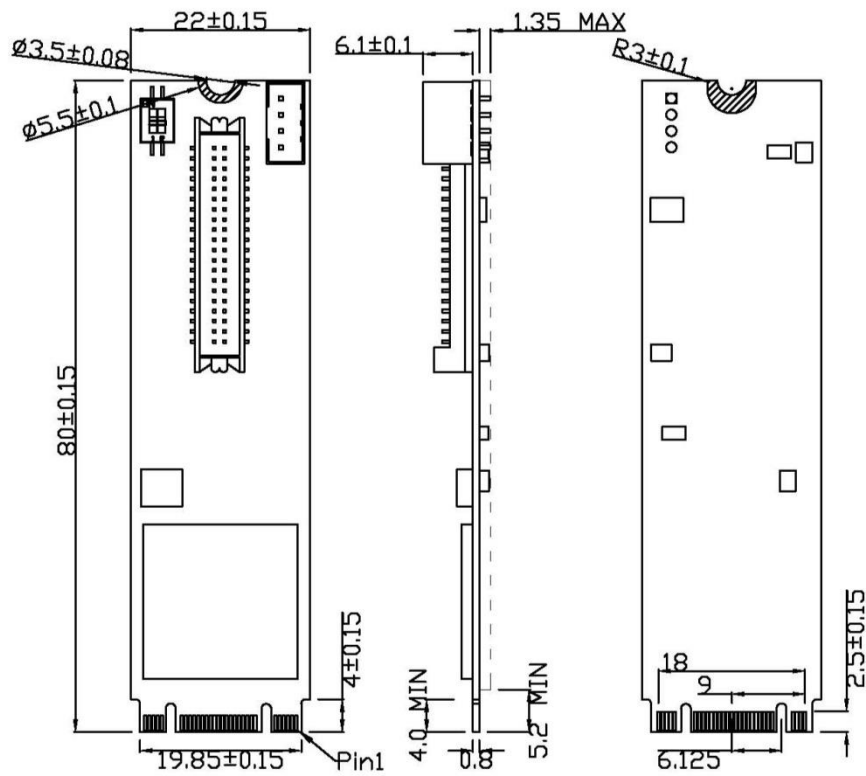

## MEC-DIS-271LW Dimensions

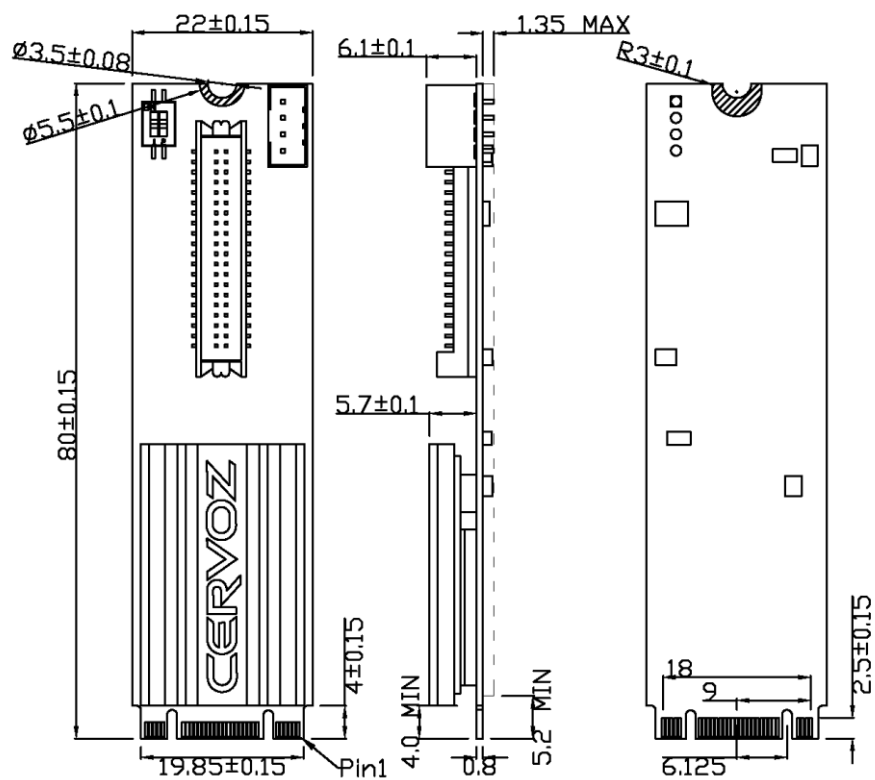



## ❑ **Product Warranty Statement**

Cervoz products are warranted to be free from manufacturing defects in materials and workmanship starting from the date of delivery. The actual warranty period of Cervoz products vary with product categories. Complete details can be found here:

<http://www.cervoz.com/support/warranty.php>

During the warranty period, we shall, at our option, either repair or replace any product that proves to be defective under normal operation.

Defects, malfunctions, or failures of the warranted product caused by damage resulting from natural disasters (such as by lightning, flood, earthquake, etc.), environmental and atmospheric disturbances, other external forces such as power line disturbances, plugging the board in under power, or incorrect cabling, and damage caused by misuse, abuse, and unauthorized alteration or repair, and the product in question is either software, or an expendable item (such as a fuse, battery, etc.), are not warranted.

### **RMA Instruction**

- Customers must fill in Cervoz Return Merchandise Authorization (RMA) Request Form and obtain a RMA number prior to returning a defective product to Cervoz for service.
- Customers must collect all the information about the problems encountered and note anything abnormal and describe the problems on the "Cervoz Service Form" for the RMA number application process.
- Charges may be incurred for certain repairs. Cervoz will charge for repairs to products whose warranty period has expired. Cervoz will also charge for repairs to products if the damage resulted from acts of God, environmental or atmospheric disturbances, or other external forces through misuse, abuse, or unauthorized alteration or repair. If charges will be incurred for a repair, Cervoz lists all charges, and will wait for customer's approval before performing the repair.
- Customers agree to insure the product or assume the risk of loss or damage during transit, to prepay shipping charges, and to use the original shipping container or equivalent.
- Customers can send back faulty products with or without accessories (manuals, cable, etc.) and any components from the card. If the components were suspected as part of the problems, please note clearly. Otherwise, Cervoz is not responsible for the devices/parts.
- Repaired items will be shipped along with a "Repair Report" detailing the findings and actions taken.

### **Limitation of Liability**

Cervoz' liability arising out of the manufacture, sale, or supplying of the product and its use, whether based on warranty, contract, negligence, product liability, or otherwise, shall not exceed the original selling price of the product. The remedies provided herein are the customer's sole and exclusive remedies. In no event shall Cervoz be liable for direct, indirect, special or consequential damages whether based on contract of any other legal theory.