

# MEC-WIFI-2532B-30

WLAN 802.11 a/b/g/n/ac 2T2R BT 4.2 NGFF Card

M.2 Type 2230 key-A-E

*Product Datasheet*





## Revision History

Date	Revision	Description
2018.04.18	1.0	First Released



## Table of Contents

- Introduction and Product Features.....4
- Hardware Specification.....5
- Block Diagram.....6
- Mechanical Specification.....7



## Introduction

MEC-WIFI-2532B-30 is a highly integrated single-chip that support 2-stream 802.11ac solutions with Multi-user MIMO (Multiple-Input , Multiple-Output) with Wireless LAN (WLAN) PCI Express network interface controller with integrated Bluetooth Smart Ready USB interface controller. It combines a WLAN MAC, a 2T2R capable WLAN baseband, and RF in s single chip.

MEC-WIFI-2532B-30 provides a complete solution for a high- performance integrated wireless and Bluetooth device.

## Product Features

- Form factor: NGFF M.2 2230 type
- IEEE 802.11a/b/g/n/ac draft 2.0 compatible WLAN
- WLAN supports 2.4GHz and 5GHz channel
- 2T2R MIMO technology for extended reception robustness and exceptional throughput
- Bluetooth: BT 2.1/3.0/4.0/4.1/4.2
- Max. PHY data rate: 866.7Mbps using 80MHz bandwidth
- I/O: WLAN: PCIe1.1. BT: USB 2.0
- 2 x 50 Ohm RF connectors for 2.4G/5G diversity data transmission
- Win8 and Win10 OS supported
- RoHS compliant



## Hardware Specification

General Specification	
IEEE Networking Standard	IEEE 802.11 a/b/g/n/ac Wireless Local Area Networks
RF Frequency Range	2.4G~2.5GHz / 5.725~5.785GHz ISM Dual Band
PHY Rate	173Mbps using 20MHz bandwidth 300Mbps using 40MHz bandwidth 866.7Mbps using 80MHz bandwidth
MIMO Technology	2T2R
IEEE 802.11i security mechanisms	WPA, WPA2. Open, shared key, pairwise key authentication
Other IEEE standard	802.11e QoS Enhancement(WMM) 802.11h DFS, TPC, Spectrum measurement
Operating Voltage	+3.3V (+/-0.3V)
Interface	WLAN: PCIe 1.1      Bluetooth: USB2.0
Board Specification	
WLAN Chip	Realtek RTL8822BE
BT Chip	Realtek RTL8822BE
Antenna	External antenna (not included)
RF connector	Micro coaxial SMD : Foxconn HD9601F-T2 or iPEX 20279-001E-01, or equivalent
Form Factor	NGFF M.2 2230 type
RF Connector #	2
Antenna design	Two antenna for TX/RX, Diversity (Antenna is not included for standard package)
Environmental	
Operating	Operating temperature: 0 to 85 degree C Relative Humidity : 5-90% (non-condensing)
Storage	Temperature: -20 to 85 degree C Relative Humidity : 5-95% (non-condensing)
Frequency range	2.4GHz and 5GHz band
Software Support	
Operating System	Windows 7, 8 , 10 Realtek WLAN driver ready Linux. Android 6.0
EMI Test Report	FCC/CE/TELEC/KC ready



### Block Diagram

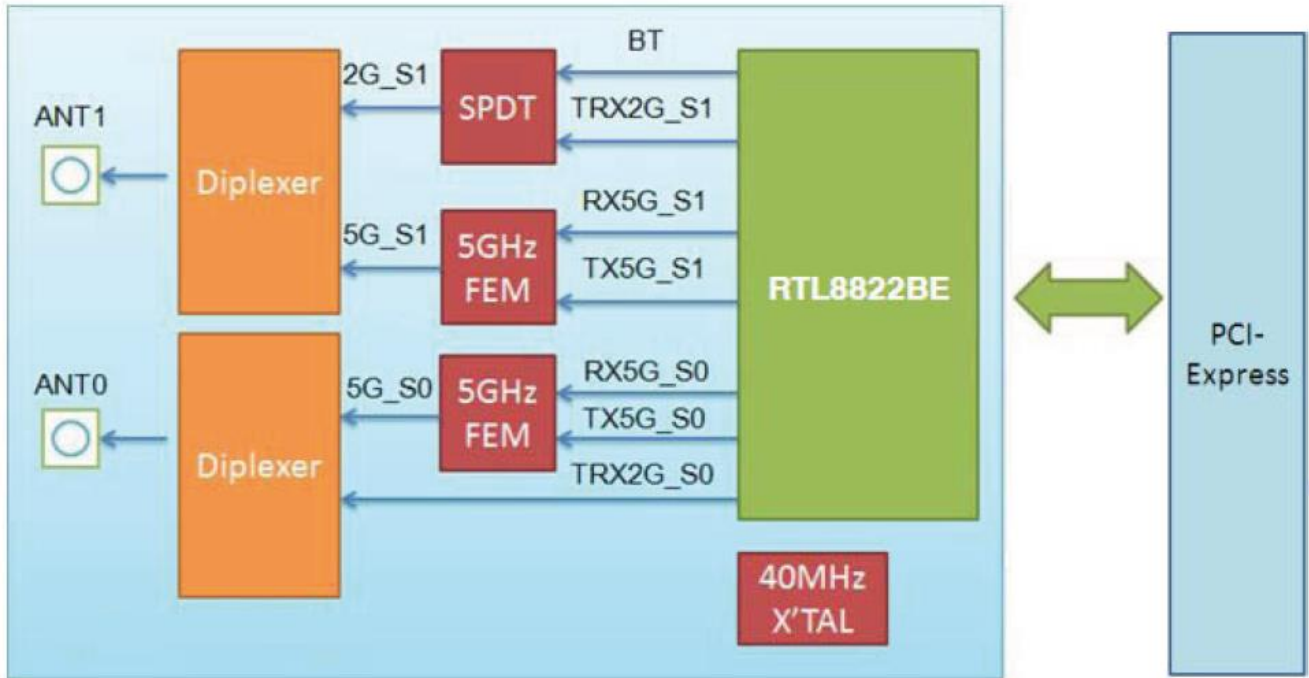



### Mechanical Specification

Board Dimension			
Form factor	NGFF M.2 2230		
PCB Dimension	30L*22W mm		
PCB thickness	0.8mm (+/- 0.1mm)		
SMD	Single side		
Max. height of components (from PCB)	Top side	Shielding case	2.3mm (+/- 0.2mm)
	Bottom side	0mm	

### Mechanical Drawing

