

# Cervoz Industrial Embedded Module

mSATA

Reliance Series (RO-MLC)

R335 Family

*Product Datasheet*





## Revision History

Date	Revision	Description
2016.12.16	1.0	First Released
2016.12.21	2.0	Modify the 2.1 MTBF / TBW data

## Table of Contents

<b>1. Product Overview.....</b>	<b>4</b>
1.1 Introduction.....	4
1.2 Application Fields.....	4
1.3 Features.....	4
1.4 Product Appearance & Models.....	5
<b>2. Product Specifications.....</b>	<b>6</b>
2.1 General Specifications.....	6
2.2 Performance.....	7
2.3 Drive Capacity.....	7
2.4 Electronic Specifications.....	8
2.4.1 Block Diagram.....	8
2.4.2 Pin Assignment.....	9
2.5 Environmental Specifications.....	10
2.6 Mechanical Specifications.....	10
<b>3. Supported Command.....</b>	<b>11</b>
3.1 List of Command Sets.....	11~13
3.2 Identify Device.....	14~16
3.3 Identify Device SMART Feature Set.....	17
3.4 SMART Data Feature.....	17
3.5 SMART Attributes.....	18
<b>4. Part No. Decoder.....</b>	<b>19</b>
4.1 Part No. Decoder.....	19~20

## 1. Product Overview

### 1.1 Introduction

Cervoz Industrial mSATA Embedded Module R335 family is a Solid State Disk product that is in compliance with the mSATA form factor and SATA III standards. mSATA R335 family fits in any mSATA sockets in a PC or motherboard; it can be used for both booting and storage purposes.

R335 family uses preselected multi-level cell (MLC) NAND flash memory from the industry leading manufacturer Micron and utilizes our “Reliability Optimized-MLC (RO-MLC) Technology”. We adopt specialized firmware to control MLC NAND flash which only uses the strong pages of MLC NAND as storage; the technology is manipulated at the block level, and with each block's capacity halved by treating it as SLC. This product includes various capacities to choose from.

R335 family offers high performance with reliability and endurance, as well as a remarkable price-performance ratio, ideal for applications in harsh environments. Industrial PC/Embedded PC, Factory Automation, Transportation, Information & Entertainment and Server & Cloud Computing all benefit from this superior reliability and cost-effectiveness.

### 1.2 Application Fields

- Industrial PC and Thin Client
- Ticketing, Examining and Testing Machine
- Military, Health and Automatic Equipment
- Server, Cloud Computer

### 1.3 Features

- Compliant with SATA III 6.0Gb/s (backward compatible to 1.5Gb/s and 3Gb/s)
- MLC NAND flash memory with RO-MLC technology
- Capacity: 16GB ~ 64GB
- With 16-bit wide DDR3 DRAM Buffer
- Operating as boot disk
- Low power consumption
- Shock resistance and anti-vibration
- Static and dynamic wear leveling
- Bad block management
- S.M.A.R.T. & TRIM command
- Fully compatible with Windows XP, Windows 7, Windows 8, Windows 10, Mac OS, and Linux
- RoHS compliant

## 1.4 Product Appearance & Models

### Cervoz Industrial mSATA Module R335



R335 Family Standard Temp. (0°C ~ 70°C) Model No.	Capacity
CIE-MSR335MKB016GS	16GB
CIE-MSR335MKB032GS	32GB
CIE-MSR335MKB064GS	64GB

**Please Note:**

Since certain storage capacity has to be reserved for firmware and controller management purposes; the physical capacity of the SATA flash module will be approximately 92.5% of the indicated capacity. If you need to install an image that has the exact (or close to) the indicated size of the flash module, please choose your flash module with a greater capacity.

## 2. Product Specifications

### 2.1 General Specifications

<b>Form Factor</b>	mSATA
<b>Interface</b>	SATA III 6.0Gb/s (backward compatible to 3.0Gb/s, 1.5Gb/s)
<b>Connector</b>	mSATA
<b>NAND Flash Type</b>	MLC (Controlled by Reliability Optimized-MLC Technology)
<b>Capacity</b>	16GB/32GB/64GB
<b>Sequential Read</b>	up to 490MB/s
<b>Sequential Write</b>	up to 225MB/s
<b>DDR3 DRAM Buffer</b>	Included
<b>ECC Scheme</b>	up to 66bits / 1K Byte
<b>MTBF</b>	3,000,000 hours
<b>Terabyte Written (TBW)</b>	16GB : 104 32GB : 208 64GB : 416
<b>Low Power Management</b>	DEVSLEEP mode DIPM/HIPM mode
<b>Supply Voltage</b>	+3.3V DC $\pm$ 5%
<b>Power Consumption</b>	Active mode: < 275mW Idle mode: < 60mW DEVSLEEP mode: < 5mW
<b>Dimension (LxWxH)</b>	50.95*30.00*3.90mm
<b>Weight</b>	6.9 $\pm$ 1g

## 2.2 Performance

The performance was measured with below PC configuration:

- Platform: GIGABYTE GA-Z97MX-Gaming5 (Intel Z97)
- RAM: Cervoz CIR-S3DUSI1302G(DDR3 2G 1333MHz)
- Operation Systems: Windows 7 SP1
- Testing Utility: Crystal Disk Mark v3.0 x64
- SATAIII port (6.0 Gb/s) performance

Capacity	16GB	32GB	64GB
Sequential Read (max.)	200MB/s	400MB/s	490MB/s
Sequential Write (max.)	55MB/s	110MB/s	225MB/s
4KB Random Read (QD32)	65MB/s	120MB/s	210MB/s
4KB Random Write (QD32)	55MB/s	110MB/s	215MB/s

## 2.3 Drive Capacity

Capacity	Cylinders	Heads	Sectors	Max LBA
16GB	16,383	16	63	31,277,232
32GB	16,383	16	63	62,533,296
64GB	16,383	16	63	62,533,296

## 2.4 Electronic Specifications

### 2.4.1 Block Diagram

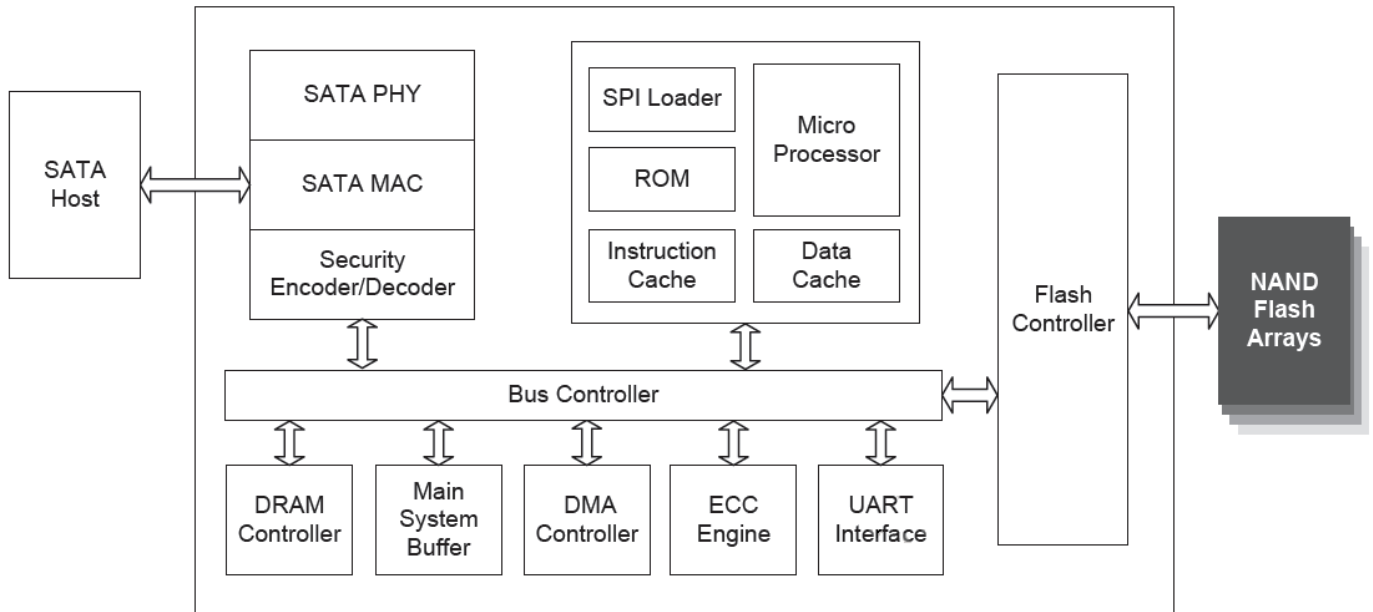



## 2.4.2 Pin Assignment

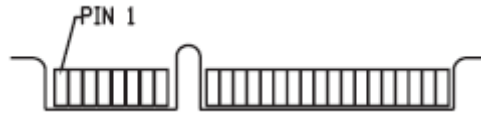

Pin #	Pin Description	Signal Name	Pin #	Pin Description	Signal Name
1	NC	NA	27	System ground	GND
2	DC 3.3V power in	+3.3V	28	Reserved pin	Reserved
3	NC	NA	29	System ground	GND
4	System ground	GND	30	NC	NA
5	NC	NA	31	SATA Differential RX-	SATA_RX-
6	Reserved pin	Reserved	32	NC	NA
7	NC	NA	33	SATA Differential RX+	SATA_RX+
8	NC	NA	34	System ground	GND
9	System ground	GND	35	System ground	GND
10	NC	NA	36	Reserved pin	Reserved
11	NC	NA	37	System ground	GND
12	NC	NA	38	Reserved pin	Reserved
13	NC	NA	39	DC 3.3V power in	+3.3V
14	NC	NA	40	System ground	GND
15	System ground	GND	41	DC 3.3V power in	+3.3V
16	NC	NA	42	NC	NA
17	NC	NA	43	NC	NA
18	System ground	GND	44	Device sleep signal in	DEVSLP
19	Reserved pin	Reserved	45	NC	NA
20	Reserved pin	Reserved	46	NC	NA
21	System ground	GND	47	NC	NA
22	NC	NA	48	Reserved pin	Reserved
23	SATA Differential TX+	SATA_TX+	49	Data access signal out	DAS
24	DC 3.3V power in	+3.3V	50	System ground	GND
25	SATA Differential TX-	SATA_TX-	51	System ground	GND
26	System ground	GND	52	DC 3.3V power in	+3.3V

## 2.5 Environmental Specifications

Type		Value
Temperature	Standard Temperature Operating:	0°C~70°C
	Standard Temperature Storage:	-40°C~85°C
Humidity	Operating & Storage	5~95%, Non-Condensing
Vibration	Non-Operating	20G, 10Hz~2000Hz
Shock	Non-Operating	1500G, 0.5ms

## 2.6 Mechanical Specifications

Type	Value
Form Factor	mSATA
Length	50.95mm +0 / -0.30mm
Width	30.00mm +0 / -0.30mm
Thickness	3.90mm ± 0.30mm

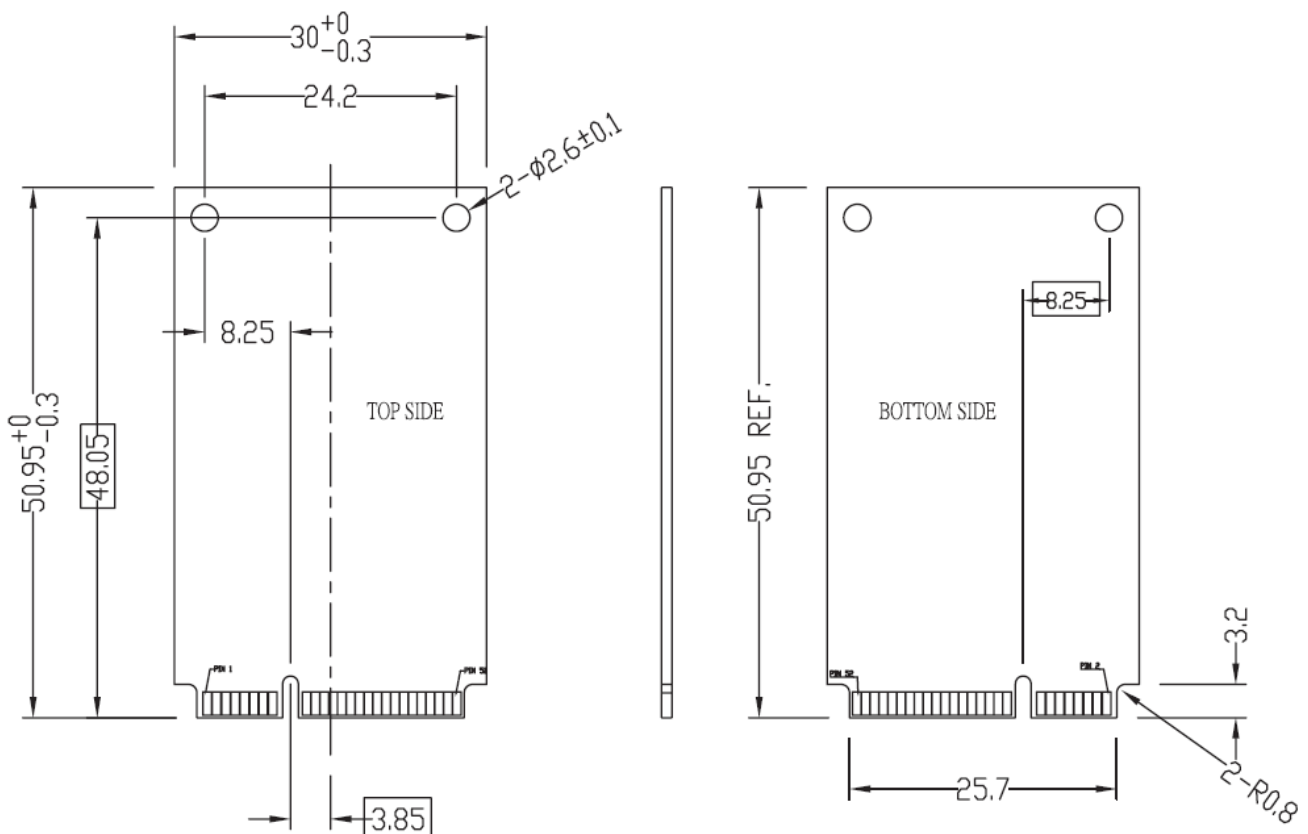

### 3. Supported Command

#### 3.1 List of Command Sets

Command	Code	Protocol
<b>General Feature Set</b>		
Execute Device Diagnostic	90h	Execute device diagnostic
Download Microcode	92h	PIO data-out
Download Microcode DMA	93h	DMA
Flush Cache	E7h	Non-data
Identify Device	ECh	PIO data-in
Initialize Drive Parameters	91h	Non-data
NOP	00h	Non-data
Read Buffer	E4h	PIO data-in
Read Buffer DMA	E9h	DMA
Read DMA	C8h or C9h	DMA
Read Log Ext	2Fh	PIO data-in
Read Log DMA Ext	47h	DMA
Read Multiple	C4h	PIO data-in
Read Sector(s)	20h or 21h	PIO data-in
Read Verify Sector(s)	40h or 41h	Non-data
Set Feature	EFh	Non-data
Set Multiple Mode	C6h	Non-data
Write Buffer	E8h	PIO data-out
Write Buffer DMA	EBh	DMA
Write DMA	CAh or CBh	DMA
Write Log Ext	3Fh	PIO data-out
Write Log DMA Ext	57h	DMA
Write Multiple	C5h	PIO data-out
Write Sector(s)	30h	PIO data-out
<b>Power Management Feature Set</b>		
Check Power Mode	E5h or 98h	Non-data
Idle	E3h or 97h	Non-data
Idle Immediate	E1h or 95h	Non-data
Sleep	E6h or 99h	Non-data
Standby	E2h or 96h	Non-data
Standby Immediate	E0h or 94h	Non-data

Command	Code	Protocol
<b>Security Mode Feature Set</b>		
Security Set Password	F1h	PIO data-out
Security Unlock	F2h	PIO data-out
Security Erase Prepare	F3h	Non-data
Security Erase Unit	F4h	PIO data-out
Security Freeze Lock	F5h	Non-data
Security Disable Password	F6h	PIO data-out
<b>SMART Feature Set</b>		
SMART Disable Operations	B0h	Non-data
SMART Enable/Disable Autosave	B0h	Non-data
SMART Enable Operations	B0h	Non-data
SMART Execute OFF-LINE Immediate	B0h	Non-data
SMART Read Log	B0h	PIO data-in
SMART Read Data	B0h	PIO data-in
SMART Read Threshold	B0h	PIO data-in
SMART Return Status	B0h	Non-data
SMART Save Attribute Values	B0h	Non-data
SMART Write Log	B0h	PIO data-out
<b>Host Protected Area Feature Set</b>		
Read Native Max Address	F8h	Non-data
Set Max Address	F9h	Non-data
Set Max Set Password	F9h	PIO data-out
Set Max Lock	F9h	Non-data
Set Max Freeze Lock	F9h	Non-data
Set Max Unlock	F9h	PIO data-out
<b>48-bit Address Feature Set</b>		
Flush Cache Ext	EAh	Non-data
Read Sector(s) Ext	24h	PIO data-in
Read DMA Ext	25h	DMA
Read Multiple Ext	29h	PIO data-in
Read Native Max Address Ext	27h	Non-data
Read Verify Sector(s) Ext	42h	Non-data
Set Max Address Ext	37h	Non-data
Write DMA Ext	35h	DMA
Write DMA FUA Ext	3Dh	DMA
Write Multiple Ext	39h	PIO data-out
Write Multiple FUA Ext	CEh	PIO data-out
Write Sector(s) Ext	34h	PIO data-out



Command	Code	Protocol
NCQ Feature Set		
Read FPDMA Queued	60h	DMA Queued
Write FPDMA Queued	61h	DMA Queued
DCO Feature Set		
Device Configuration	B1h	/
Sanitize Device Feature Set		
Sanitize Device	B4h	/
Miscellaneous and Historical Commands		
Data Set Management	06h	DMA
Seek	70h	Non-data
Recalibrate	10h	Non-data
Write Verify	3Ch	PIO data-out
Write Uncorrectable Ext	45h	Non-data



### 3.2 Identify Device

Word	F/V	Default Value	Description
0	F	0040h	General configuration
1	X	XXXXh	Default number of cylinders
2	V	0000h	Reserved
3	X	00XXh	Default number of heads
4	X	0000h	Obsolete
5	X	0240h	Obsolete
6	F	XXXXh	Default number of sectors per track
7 - 8	V	XXXXh	Number of sectors per card (Word 7 = MSW, Word 8 = LSW)
9	X	0000h	Obsolete
10 - 19	F	XXXXh	Serial number in ASCII (Right justified)
20	X	0002h	Obsolete
21	X	0002h	Obsolete
22	X	0000h	Obsolete
23 - 26	F	XXXXh	Firmware revision in ASCII Big Endian Byte Order in Word
27 - 46	F	XXXXh	Model number in ASCII (Left justified) Big Endian Byte Order in Word
47	F	8001h	Maximum number of sectors on Read/Write Multiple command
48	F	0000h	Reserved
49	F	0F00h	Capabilities
50	F	4000h	Capabilities
51	F	0200h	PIO data transfer cycle timing mode
52	X	0000h	Obsolete
53	F	0007h	Field validity
54	X	XXXXh	Current numbers of cylinders
55	X	XXXXh	Current numbers of heads
56	X	XXXXh	Current sectors per track
57 - 58	X	XXXXh	Current capacity in sectors (LBAs) (Word 57 = LSW , Word 58 = MSW)
59	F	0101h	Multiple sector setting
60 - 61	F	XXXXh	Total number of user addressable logical sectors for 28-bit commands (DWord)



Word	F/V	Default Value	Description
62	X	0000h	Reserved
63	F	0207h	Multiword DMA transfer Supports MDMA mode 0, 1 and 2
64	F	0003h	Advanced PIO modes supported
65	F	0078h	Minimum Multiword DMA transfer cycle time per word
66	F	0078h	Recommended Multiword DMA transfer cycle time
67	F	0078h	Minimum PIO transfer cycle time without flow control
68	F	0078h	Minimum PIO transfer cycle time with IORDY flow control
69	F	4000h	Additional supported
70 - 74	F	0000h	Reserved
75	F	001Fh	Queue depth
76	F	070Eh	Serial ATA capabilities <ul style="list-style-type: none"><li>• Supports Serial ATA Gen3</li><li>• Supports Serial ATA Gen2</li><li>• Supports Serial ATA Gen1</li><li>• Supports Phy event counters log</li><li>• Supports receipt of host initiated power management requests</li><li>• Supports Native Command Queuing</li></ul>
77	F	0080h	Serial ATA additional capability <ul style="list-style-type: none"><li>• DevSleep to Reduced Power State</li></ul>
78	F	0148h	Serial ATA features supported <ul style="list-style-type: none"><li>• Supports Device Sleep</li><li>• Supports software settings preservation</li></ul>
79	V	0040h	Reserved
80	F	03F0h	Major version number (ACS-2)
81	F	0000h	Minor version number
82	F	742Bh	Command sets supported 0
83	F	7500h	Command sets supported 1
84	F	4023h	Command sets supported 2
85 - 87	V	XXXXh	Command set/feature enabled
88	V	007Fh	Ultra DMA mode supported and selected
89	F	0003h	Time required for a Normal Erase mode Security Erase Unit command
90	F	0001h	Time required for an Enhanced Erase mode Security Erase Unit
91	V	0000h	Current advanced power management value
92	V	FFFEh	Master password identifier

Word	F/V	Default Value	Description
93 - 99	V	0000h	Reserved
100 - 103	V	XXXXh	Maximum user LBA for 48-bit address feature set
104	V	0000h	Reserved
105	F	0100h	Maximum number of 512-byte blocks per Data Set Management
106 - 127	V	0000h	Reserved
128	V	0001h	Security status
129 - 159	X	XXXXh	Vendor specific
160	F	0000h	Power requirement description
161	X	0000h	Reserved
162	F	0000h	Key management schemes supported
163	F	0000h	CF Advanced True IDE Timing mode capability and setting
164 - 168	V	0000h	Reserved
169	F	0001h	Data Set Management supported
170 - 216	V	XXXXh	Reserved
217	F	0001h	Non-rotating media (SSD)
218 - 221	X	0000h	Reserved
222	F	107Fh	Transport major revision (SATA Rev 3.1)
223 - 254	X	0000h	Reserved
255	X	XXXXh	Integrity word

**Notes:**

1. F = content (byte) is fixed and does not change.
2. V = content (byte) is variable and may change depending on the state of the device or the commands executed by the device.
3. X = content (byte) is vendor specific and may be fixed or variable.



### 3.3 Identify Device SMART Feature Set

Value	Command	Value	Command
D0h	Read Data	D5h	Read Log
D1h	Read Attribute Threshold	D6h	Write Log
D2h	Enable/Disable Autosave	D8h	Enable SMART Operations
D3h	Save Attribute Values	D9h	Disable SMART Operations
D4h	Execute OFF-LINE Immediate	DAh	Return Status

If the reserved size is below the threshold, the status can be read from the Cylinder Register using the Return Status command (DAh).

### 3.4 SMART Data Feature

The following 512 bytes make up the device SMART data structure. Users can obtain the data using the “Read Data” command (D0h).

Byte	F / V	Description
0 - 1	X	Revision code
2 - 361	X	Vendor specific (see 4.3.2)
362	V	Off-line data collection status
363	X	Self-test execution status byte
364 - 365	V	Total time in seconds to complete off-line data collection activity
366	X	Vendor specific
367	F	Off-line data collection capability
368 - 369	F	SMART capability
370	F	Error logging capability <ul style="list-style-type: none"> <li>• 7-1 Reserved</li> <li>• 0 1 = Device error logging supported</li> </ul>
371	X	Vendor specific
372	F	Short self-test routine recommended polling time (in minutes)
373	F	Extended self-test routine recommended polling time (in minutes)
374	F	Conveyance self-test routine recommended polling time (in minutes)
375 - 385	R	Reserved
386 - 395	F	Firmware version/date code
396 - 399	F	Reserved
400 - 405	F	‘SM2246’
406 - 510	X	Vendor specific
511	V	Data structure checksum

### 3.5 SMART Attributes

The following table defines the vendor specific data in byte 2 to 361 of the 512-byte SMART data.

Attribute ID (hex)	Raw Attribute Value							Attribute Name
01	MSB	00	00	00	00	00	00	Read error rate
05	LSB	MSB	00	00	00	00	00	Reallocated sectors count
09	LSB			MSB	00	00	00	Power-on hours
0C	LSB			MSB	00	00	00	Power cycle count
A0	LSB			MSB	00	00	00	Uncorrectable sector count when read/write
A1	LSB	MSB	00	00	00	00	00	Number of valid spare block
A3	LSB	MSB	00	00	00	00	00	Number of initial invalid block
A4	LSB			MSB	00	00	00	Total erase count
A5	LSB			MSB	00	00	00	Maximum erase count
A6	LSB			MSB	00	00	00	Minimum erase count
A7	LSB			MSB	00	00	00	Average erase count
A8	LSB			MSB	00	00	00	Max erase count of spec
A9	LSB			MSB	00	00	00	Remain Life (percentage)
AF	LSB			MSB	00	00	00	Program fail count in worst die
B0	LSB	MSB	00	00	00	00	00	Erase fail count in worst die
B1	LSB			MSB	00	00	00	Total wear level count
B2	LSB	MSB	00	00	00	00	00	Runtime invalid block count
B5	LSB			MSB	00	00	00	Total program fail count
B6	LSB	MSB	00	00	00	00	00	Total erase fail count
BB	LSB			MSB	00	00	00	Uncorrectable error count
C0	LSB	MSB	00	00	00	00	00	Power-off retract count
C2	MSB	00	00	00	00	00	00	Controlled temperature
C3	LSB			MSB	00	00	00	Hardware ECC recovered
C4	LSB			MSB	00	00	00	Reallocation event count
C6	LSB			MSB	00	00	00	Uncorrectable error count off-line
C7	LSB	MSB	00	00	00	00	00	Ultra DMA CRC error count
E1	LSB						MSB	Total LBAs written (each write unit = 32MB)
E8	LSB	MSB	00	00	00	00	00	Available reserved space
F1	LSB						MSB	Total LBAs written (each write unit = 32MB)
F2	LSB						MSB	Total LBAs read (each read unit = 32MB)

#### 4. Part No. Decoder

##### 4.1 Part No. Decoder

1	-	2	3	4	5	6	7	8	9
Product Line	-	Form Factor	Product Series	Cervoz Family Code (Bus / Internal Control)	Flash Brand	Flash Capacity	Flash Mode	Module Capacity	Operating Temp.
XXX	-	XX	X	XXX	X	X	X	XXXX	X

##### 1. Product Line

CIS	Cervoz Industrial SSD
CIM	Cervoz Industrial Memory Card
CIE	Cervoz Industrial Embedded Module

##### 2. Form Factor

2S	2.5" SATA
2P	2.5" PATA
CF	CompactFlash
CA	CFast
MS	mSATA
HM	Half Size mSATA
HS	Half Slim
M4	M.2 2242
M6	M.2 2260
M8	M.2 2280
0V	PATA Disk 40pin Vertical
4V	PATA Disk 44pin Vertical
4L	PATA Disk 44pin Horizontal Left
7T	SATA Disk 7pin Vertical Tall
7L	SATA Disk 7pin Horizontal Left
7R	SATA Disk 7pin Horizontal Right

##### 3. Product Series

S	Supreme Series (SLC)
R	Reliance Series (RO-MLC)
M	Momentum Series (MLC)

#### 4. Cervoz Family Code

Bus and Internal Control for Cervoz Product Families

##### 5. Flash Brand

M	Micron
T	Toshiba

##### 6. Flash Capacity

A	256Mb
B	512Mb
C	1Gb
D	2Gb

E	4Gb
F	8Gb
G	16Gb
H	32Gb
I	64Gb
J	128Gb
K	256Gb
L	512Gb
M	1Tb

### 7. Flash Mode

Internal Control for Flash Mode

### 8. Module Capacity

128M	128MB
256M	256MB
512M	512MB
001G	1GB
002G	2GB
004G	4GB
008G	8GB
016G	16GB
032G	32GB
064G	64GB
128G	128GB
256G	256GB
512G	512GB

### 9. Operating Temperature

S	Standard Grade (0~ +70°C)
W	Wide Temperature Grade (-40 ~ +85°C)