

TGS-9120-M12-BP2

➤ **EN50155 12-port managed Gigabit Ethernet switch with 12x10/100/1000Base-T(X), M12 connector and 2xbypass included**

Features

- Leading EN50155-compliant Ethernet switch for rolling stock application
- Support O-Ring (recovery time < 30ms over 250 units of connection) and MSTP (RSTP/STP compatible) for Ethernet Redundancy
- O-Chain allow multiple redundant network rings
- Supports standard IEC 62439-2 MRP^{*NOTE} (Media Redundancy Protocol) function
- Supports IEEE 1588v2 clock synchronization
- Supports IPV6 new internet protocol version
- Supports Modbus TCP protocol
- Supports IEEE 802.3az Energy-Efficient Ethernet technology
- Provided HTTPS/SSH protocol to enhance network security
- Supports IP-based bandwidth management
- Supports application-based QoS management
- Supports Device Binding security function
- Supports DOS/DDOS auto prevention
- IGMP v2/v3 (IGMP snooping support) for filtering multicast traffic
- Supports SNMP v1/v2c/v3 & RMON & 802.1Q VLAN Network Management
- Supports ACL, TACACS+ and 802.1x User Authentication for security
- Supports 9.6K Bytes Jumbo Frame
- Multiple notification for warning of unexpected event
- Web-based, Telnet, Console (CLI), and Windows utility (Open-Vision) configuration
- Supports LLDP Protocol
- Wall mounting enabled



*NOTE: This function is available by request only

Introduction

ORing's Transporter™ series managed Ethernet switches are designed for industrial applications, such as rolling stock, vehicle, and railway applications. TGS-9120-M12-BP2 is managed Redundant Ring Ethernet switch with 12x10/100/1000Base-T(X) ports which is specifically designed for the toughest and fully compliant with EN50155 requirement. The switch support Ethernet Redundancy protocol, O-Ring (recovery time < 30ms over 250 units of connection), O-Chain, MRP^{*NOTE} and MSTP/RSTP/STP (IEEE 802.1s/w/D) can protect your mission-critical applications from network interruptions or temporary malfunctions with its fast recovery technology. TGS-9120-M12-BP2 includes 2 sets of bypass ports that protect the network from failures and Network maintenance by ensuring network integrity during power loss. And support wide operating temperature from -40°C to 75°C. TGS-9120-M12-BP2 can also be managed centralized and convenient by Open-Vision, Except the Web-based interface, Telnet and console (CLI) configuration. Therefore, the switch is one of the most reliable choices for EN50155 highly-managed Ethernet application.

- **O-Ring:** O-Ring is ORing's proprietary redundant ring technology, with recovery time of less 30 milliseconds and up to 250 nodes. The O-Ring redundant ring technology can protect mission-critical application from network interruptions or temporary malfunction with its fast recover technology.
- **O-Chain:** O-Chain is the revolutionary network redundancy technology that provides the add-on network redundancy topology for any backbone network, O-Chain allows multiple redundant network rings of different redundancy protocols to join and function together as a larger and more robust compound network topology. O-Chain providing ease-of-use while maximizing fault-recovery swiftness, flexibility, compatibility, and cost-effectiveness in one set of network redundancy topology.

- **MRP: Media Redundancy Protocol (MRP)** ^{*NOTE} is a data network protocol standardized by the IEC 62439-2. It allows rings of Ethernet switches to overcome any single failure with recovery time much faster than achievable with Spanning Tree Protocol.
- **IP-based Bandwidth Management:** The switch provides advanced IP-based bandwidth management which can limit the maximum bandwidth for each IP device. User can configure IP camera and NVR with more bandwidth and limit other device bandwidth.
- **Application-Based QoS:** The switch also supports application-based QoS. Application-based QoS can set highest priority for data stream according to TCP/UDP port number.
- **Device Binding Function:** ORing special Device Binding function can only permit allowed IP address with MAC address to access the network. Hacker cannot access the IP surveillance network without permission. It can avoid hacker from stealing video privacy data and attacking IP camera, NVR and controllers.
- **Advanced DDoS/DDoS Auto Prevention:** The switch also provided advanced DDoS/DDoS auto prevention. If there is any IP flow become big in short time, the switch will lock the source IP address for certain time to prevent the attack. It's hardware-based prevention so it can prevent DDoS/DDoS attack immediately and completely.
- **IEEE 1588v2 Technology:** The IEEE 1588v2 technology can fulfill precision time synchronization requirements for protection and control applications.
- **Modbus TCP:** This is a Modbus variant used for communications over TCP/IP networks.
- **IEEE 802.3az Energy-Efficient Ethernet:** This is a set of enhancements to the twisted-pair and backplane Ethernet family of networking standards that will allow for less power consumption during periods of low data activity. The intention was to reduce power consumption by 50% or more.

***NOTE: This function is available by request only**

Open-Vision

ORing's switches are intelligent switches. Different from other traditional redundant switches, ORing provides a set of Windows Utility (Open-Vision) for user to manage and monitor all of industrial Ethernet switches on the industrial network.

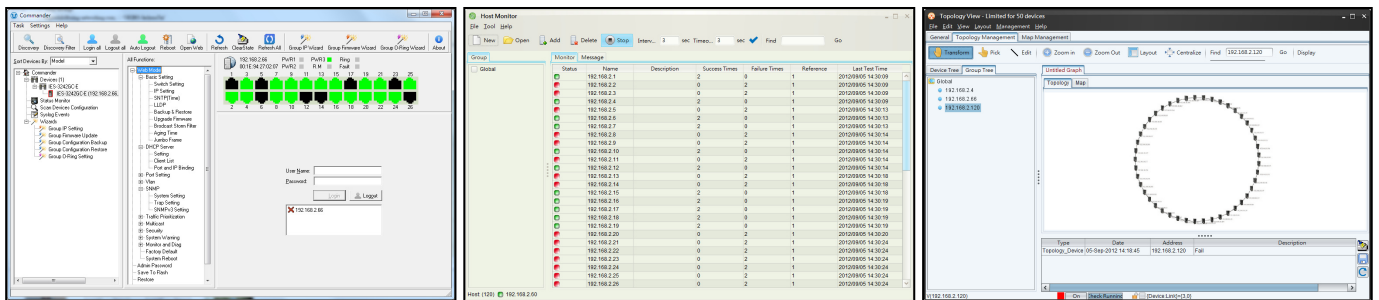

Commander

Host Monitor

Topology View

ORing Open-Vision Version 4.0
Powerful Network Management Windows Utility

Key Features and Learning Objectives:

- Learn group binding view and group configuration
- Auto learning device health status and configuration monitoring
- Location query for device position
- Mapping and monitoring for device status
- Back up configuration, firmware upgrade and reset
- Device management
- Support SNMP and J1939 protocol device
- Multi-point monitoring

Open-Vision 4.0
Powerful Network Management Windows Utility

- Multi-link topology
- Centralized management view
- Traffic monitoring

Dimensions

Unit =mm (Tolerance ±0.5mm)

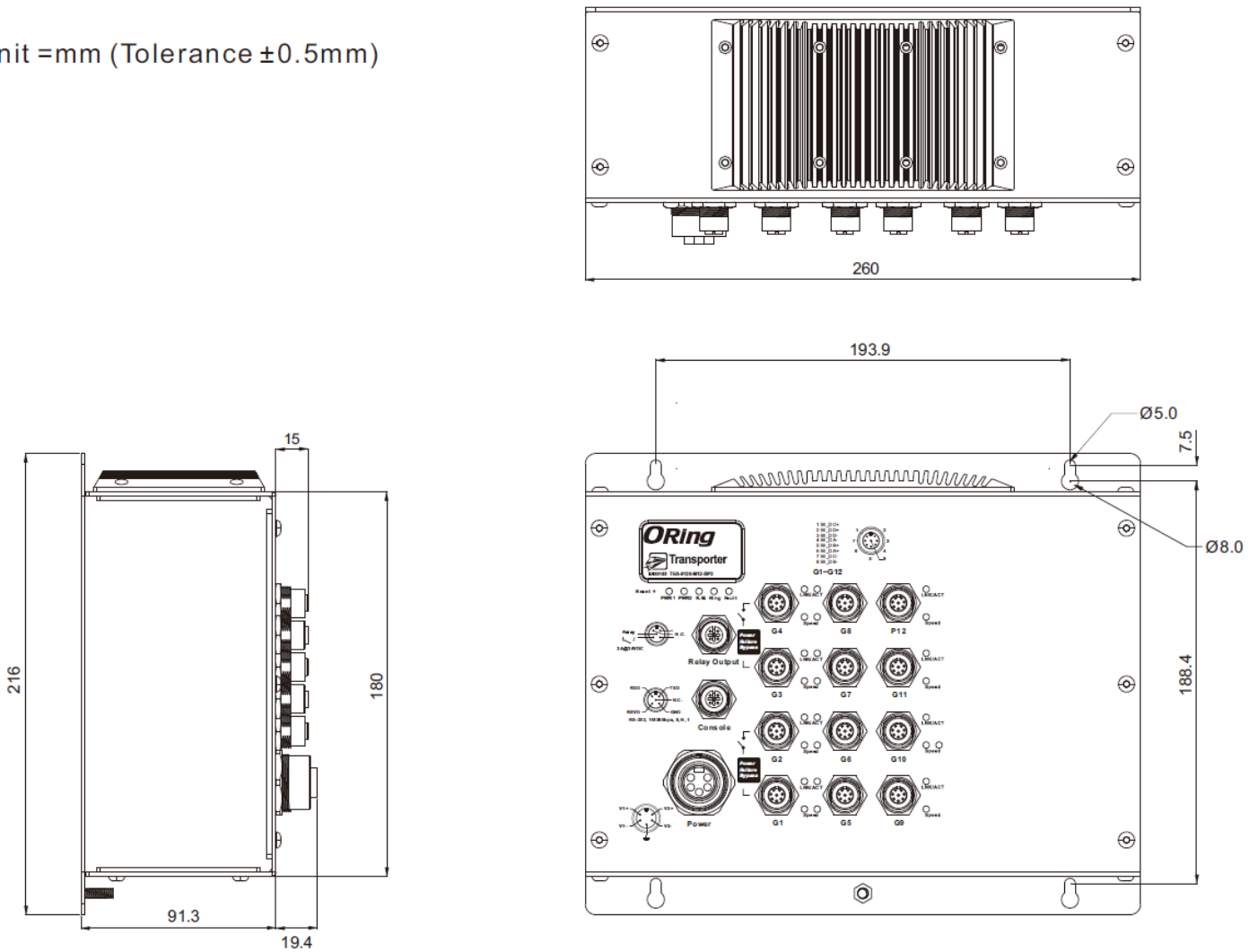

Pin Definition

		10/100/1000Base-T(X) M12 port	
		Pin No.	Description
A-Coding M12	#1	BI_DC+	
	#2	BI_DD+-	
	#3	BI_DD-	
	#4	BI_DA-	
	#5	BI_DB+	
	#6	BI_DA+	
	#7	BI_DC-	
	#8	BI_DB-	

Specifications

ORing Switch Model	TGS-9120-M12-BP2
Physical Ports	
10/100/1000Base-T(X) Ports in M12 Auto MDI/MDIX	12 (8-pin female A-coding with 2xbypass function included)
Technology	
Ethernet Standards	IEEE 802.3 for 10Base-T IEEE 802.3u for 100Base-TX IEEE 802.3ab for 1000Base-T IEEE 802.3x for Flow control IEEE 802.3ad for LACP (Link Aggregation Control Protocol) IEEE 802.1p for COS (Class of Service) IEEE 802.1Q for VLAN Tagging IEEE 802.1w for RSTP (Rapid Spanning Tree Protocol) IEEE 802.1s for MSTP (Multiple Spanning Tree Protocol) IEEE 802.1x for Authentication IEEE 802.1AB for LLDP (Link Layer Discovery Protocol)
MAC Table	8k
Packet Buffer Size	4Mbits
Priority Queues	8
Processing	Store-and-Forward
Switch Properties	Switching latency: <7 µs Switching bandwidth: 24Gbps Throughput (packet per second): 17.856Mpps@64Bytes packet Max. Number of Available VLANs: 4095 IGMP multicast groups: 128 for each VLAN Port rate limiting: User Define
Jumbo Frame	Up to 9.6K Bytes
Security Features	Device Binding security feature Enable/disable ports, MAC based port security Port based network access control (802.1x) VLAN (802.1Q) to segregate and secure network traffic Radius centralized password management SNMPv3 encrypted authentication and access security Https / SSH enhance network security
Software Features	STP/RSTP/MSTP (IEEE 802.1D/w/s) Redundant Ring (O-Ring) with recovery time less than 30ms over 250 units TOS/Diffserv supported Quality of Service (802.1p) for real-time traffic VLAN (802.1Q) with VLAN tagging and GVRP supported IGMP Snooping IP-based bandwidth management Application-based QoS management DOS/DDOS auto prevention Port configuration, status, statistics, monitoring, security DHCP Server/Client/Relay SMTP Client Modbus TCP
Network Redundancy	O-Ring O-Chain MRP*NOTE MSTP (RSTP/STP compatible)
RS-232 Serial Console Port	RS-232 in M12 connector (5-pin female A-coding). Baud rate setting: 115200bps, 8, N, 1
LED Indicators	
Power Indicator (Power)	Green: Power LED x 2
Ring Master Indicator (R.M.)	Green: Indicates that the system is operating in O-Ring Master mode
O-Ring Indicator (Ring)	Green: Indicates that the system operating in O-Ring mode Green Blinking: Indicates that the Ring is broken.
Fault Indicator (Fault)	Red: Indicate unexpected event occurred
10/100/1000Base-T(X) M12 Port Indicator	Top Green LED for Link/Act indicator: Green for link-up, Off for link-down, Blinking for Act. Bottom dual color LED for Ethernet speed indicator: Green for 1000Mbps, Amber for 100Mbps, Off for 10Mbps
Fault Contact	

*NOTE: This function is available by request only

Relay	Relay output to carry capacity of 3A at 24VDC on M12 connector (5-pin A-coding, female connector)
Reset Function	
Reset Button	< 5 sec: System reboot, > 5 sec: Factory default
Power	
Input Power	Dual 12~48VDC inputs on 5-pin M23 female connector *NOTICE: For EN50155 applications, it supports 24VDC power inputs only.
Power Consumption (Typ.)	17.3Watts
Overload Current Protection	Present
Reverse Polarity Protection	Present
Physical Characteristic	
Enclosure	IP-30
Dimension (W x D x H)	260 (W) x 91.3 (D) x 216 (H) mm 10.24 (W) x 3.59 (D) x 8.5 (H) inch
Weight (g)	2218 g
Environmental	
Storage Temperature	-40 to 85°C (-40 to 185°F)
Operating Temperature	-40 to 75°C (-40 to 167°F)
Operating Humidity	5% to 95% non-condensing
Regulatory Approvals	
EMC	CE EMC (EN 55024, EN 55032), FCC Part 15 B, EN 50155(EN 50121-1, EN 50121-3-2)
EMI	EN 55032, CISPR32, EN 61000-3-2, EN 61000-3-3, FCC Part 15 B class A
EMS	EN 55024 (IEC/EN 61000-4-2 (ESD: Contact 4KV), IEC/EN 61000-4-3 (RS 80MHz to 1GHz: 3V/m 1kHz 80% AM), IEC/EN 61000-4-4 (EFT Power 0.5KV, Signal 0.5KV), IEC/EN 61000-4-5 (Surge: Power 0.5KV, RJ45 1KV), IEC/EN 61000-4-6 (CS 150K-80MHz: 3Vrms 1kHz 80% AM), IEC/EN 61000-4-8(PFMF), IEC/EN 61000-4-11 (DIP))
Shock	IEC60068-2-27
Free Fall	IEC60068-2-31
Vibration	IEC60068-2-6
Safety	EN 60950-1
Other	EN 50155 (IEC 61373)
MTBF	205,269.3131 hrs.
Warranty	5 years

Ordering Information

Available Model	Model Name	Description
	TGS-9120-M12-BP2	EN50155 12-port managed Gigabit Ethernet switch with 12x10/100/1000Base-T(X), M12 connector and 2xbypass included
Packing List		Optional Accessories
<ul style="list-style-type: none"> TGS-9120-M12-BP2x 1 ORing Tool CD Card x 1 Quick Installation Guide x 1 		<ul style="list-style-type: none"> Open-Vision M500: Powerful Network Management Windows Utility Suit, 500 IP devices M12 cable series