



I-87088W | I-87088W/S

8-channel PWM Output and
8-channel High-speed Counter Module

Introduction

The I-87088W provides 8-channel PWM (Pulse Width Modulation) Output and 8-channel Counter Input, and can be used to develop powerful and cost-effective analog control systems. PWM is a powerful technique for controlling analog circuits that uses the Digital Output to generate a waveform with a variable duty cycle and frequency which can then be used to control an analog circuit in applications such as controlling the position or speed of motors, the brightness of lamps, or the speed of fans, etc. Either burst mode or continuous mode can be used for the PWM output depending on the application. In addition, all Digital Input channels can be used as high-speed counters with a speed of up to 1 MHz.

The I-87088W/S allows the load voltage to be increased from +5 to +50 V for the 8-channels PWM (Pulse Width Modulation) output and the 8-channels high-speed counter.



I-87088W/S

I-87088W with
DN-8P8C/S External Board

System Specifications

Model	I-87088W	I-87088W/S
COM Ports		
Port	RS-485	
Data Format	N, 8, 1	
Baud Rate	1200 ~ 115200 bps	
Protocol	DCON	
CPU Module		
Dual Watchdog	Module (1.6 Seconds), Communication (Programmable)	
LED Indicators		
System LED Indicator	1 LED as Power Indicator	
Isolation		
Intra-module Isolation, Field-to-Logic	3750 VDC	
EMS Protection		
ESD (IEC 61000-4-2)	±4 kV Contact for Each port	
Power		
Consumption	1.7 W Max.	
Mechanical		
I/O Connector	DB-37 (Female)	
Dimensions (W x L x H)	30 mm x 115 mm x 102 mm	
Environment		
Operating Temperature	-25 ~ +75 °C	
Storage Temperature	-30 ~ +80 °C	
Humidity	10 ~ 90% RH, Non-condensing	

Features

- 8-channel PWM Output and 8-channel Counter Input
- Burst Mode and Continuous Mode for PWM Output
- Software and Hardware Trigger Mode for PWM Output
- Individual and Synchronous PWM Output
- High-speed Counters
- 4 kV ESD and EFT Protection
- Dual Watchdog
- Wide Operating Temperature Range: -25 to +75°C



I/O Specifications

Model	I-87088W	I-87088W/S
Digital Input		
Channels	8	
Contact	Wet	
Sink/Source (NPN/PNP)	Sink	
ON Voltage Level	+3.5 ~+5 VDC	+3.5 ~+50 VDC
OFF Voltage Level	+1 VDC Max.	+4 VDC Max.
Counter Bits	32-bit	
Counter Mode	Up	
Virtual Battery Backup	Yes	
Max. Speed	1 MHz	
PWM Output		
Channels	8	
Type	PWM, TTL	
Sink/Source(NPN/PNP)	Sink	
Load Voltage	+3.5 ~ +5 VDC	+3.5 ~ +50 VDC
Load Current	Sink	+5 V @ 10 mA/ Channel
	Source	+5 VDC @ 1 mA/ Channel
PWM	Frequency	1 Hz ~ 500 KHz
	Duty Cycle	0.1 ~ 99.9%
	Mode	Burst, Continuous
	Burst Count	1 ~ 65535
	Trigger Start	Hardware or Software

Applications

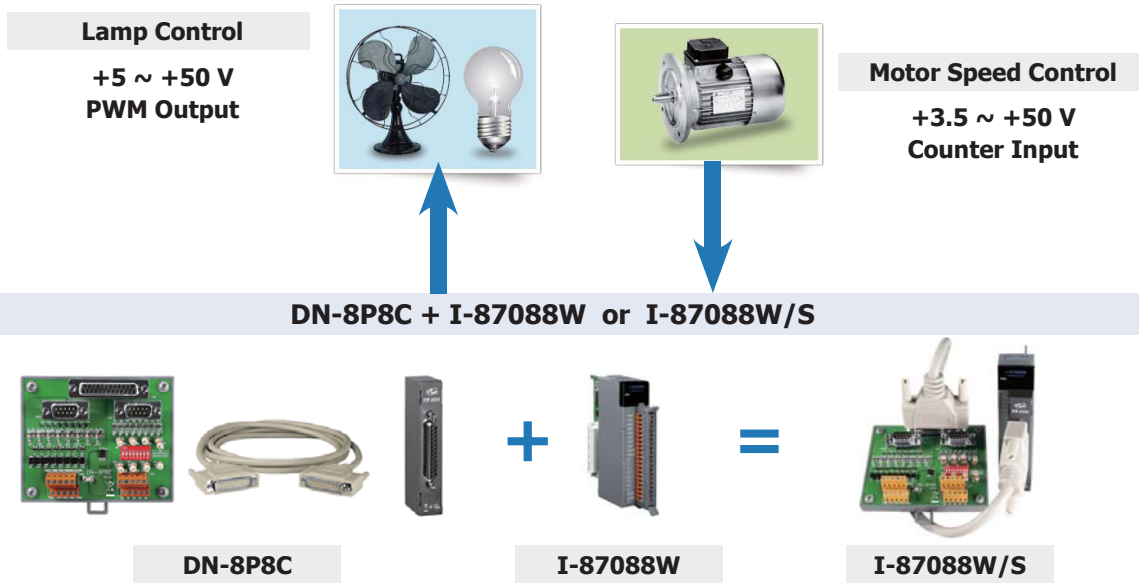

Pin Assignments

I-87088W

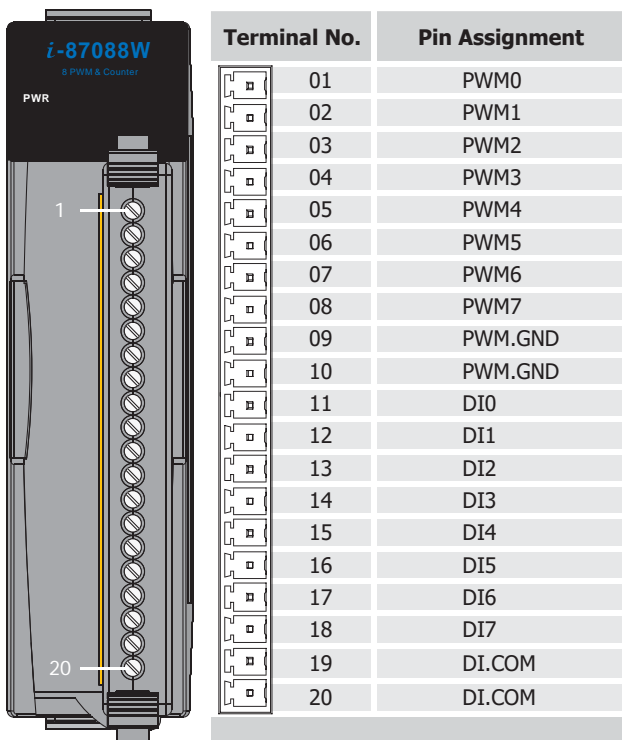

DN-8P8C

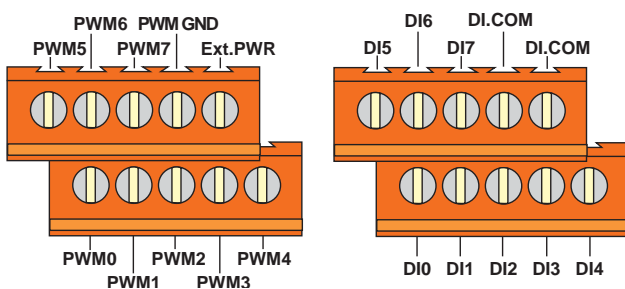

Internal I/O Structure

I-87088W

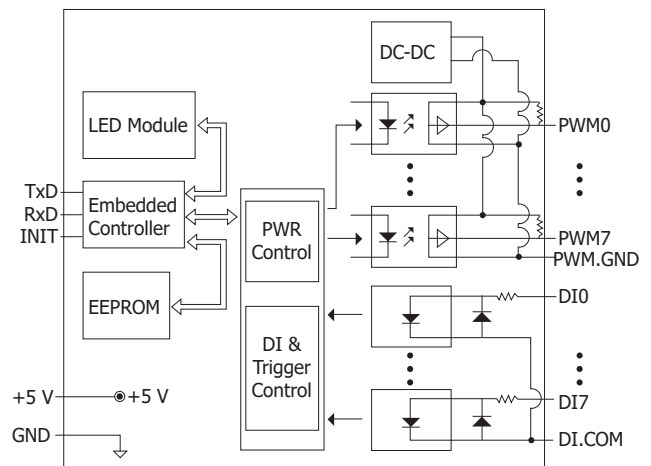

DN-8P8C

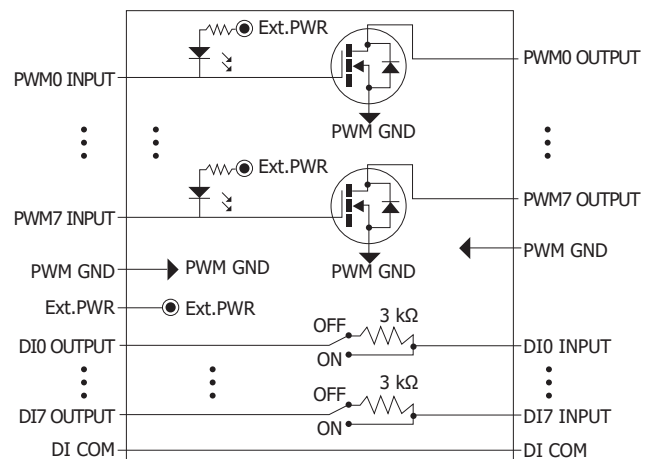

Wire Connections

I-87088W		
Input Type	ON State Readback as 1	OFF State Readback as 0
Relay Contact	<p>Relay ON</p>	<p>Relay OFF</p>
Output Type	ON State Readback as 1	OFF State Readback as 0
Sink		
Source		

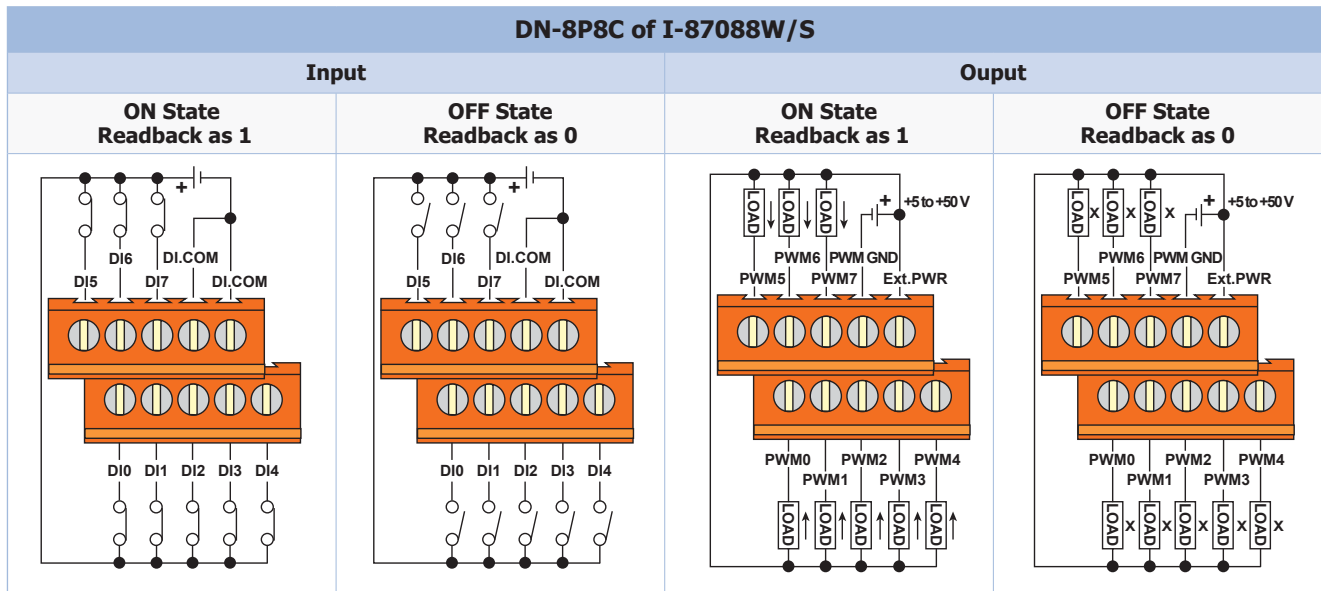

Dimensions (Unit: mm)

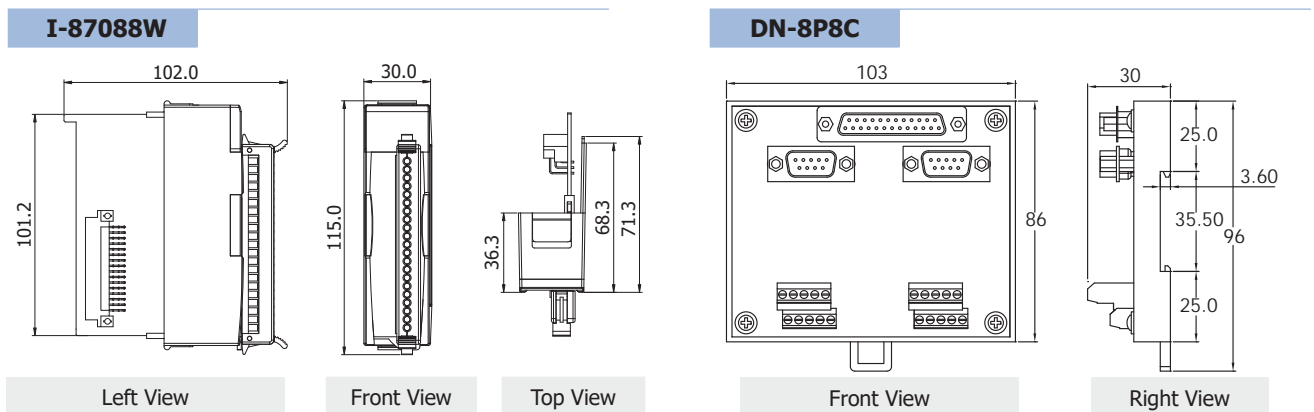

Ordering Information

I-87088W-G CR	8-channel PWM Output and 8-channel High-speed Counter Module (Gray Cover) (RoHS)
I-87088W-G/S CR	8-channel PWM Output and 8-channel High-speed Counter Module with DN-8P8C/S External Board (Gray Cover) (RoHS)