

TANK-700-QM67 720-Q67

- Intel® 2nd Gen Core™ Mobile Processor
- Intel® 2nd Gen Core™ Desktop Processor

High Performance Fanless Embedded System with 2nd Generation Intel® Core™ i7/i5/i3 Processor

Combo Gigabit LAN (SFP Fiber/RJ-45)



Features

- ◆ 2nd Gen Intel® Core™ i7/i5/i3 or Celeron® mobile processors for TANK-700
2nd Gen Intel® Core™ i7/i5/i3 Pentium® and Celeron® desktop processors for TANK-720
- ◆ Intel® HD graphics supports H.264/AVC-MPEG2/VC1, DirectX 10.1 and OpenGL 3.0
- ◆ On-board 2GB DDR3 memory and one DDR3 SO-DIMM slot (system max. 10 GB)
- ◆ Dual combo (10/100/1000 BASE-T(X) or 1000 baseSFP slot RJ-45 port) Gigabit LAN ports, supporting Intel® AMT 7.0
- ◆ Supports 8-channel audio/video capture and dual display by VGA and HDMI
- ◆ Dual-band 2.4/5 GHz 802.11a/b/g/n 3T3R MIMO Wi-Fi for high speed wireless transmission



1 Industrial Computing Solutions

8-Channel Audio/Video Capture Solution

With an H.264 codec, the TANK-700/720 series is capable of compressing and decompressing Full HD (1920x1080) video in real-time without increasing CPU loadings. By supporting real-time recording, previewing, and HD video transmission through surveillance devices, the TANK-700/720 series is suitable as an intelligent monitoring system and transportation intelligent scheduling system solution.

2 x 4-channel audio/video capture (system model name: IVCS-7008)

2 Video Capture Solutions

Fully Integrated I/O

Power switch and LED

1. Long-press 3 sec. to power on
2. Long-press 6 sec. to power off



3 Embedded Computing Solutions

4 ORing Network Communication

5 Power Supply/Peripherals

6 Panel Solutions Introduction

ACC on/off
ACC on mode is designed for vehicle applications. Use the ACC signal to control power on/off.

AT/ATX mode
Users can select a suitable mode according to the application.

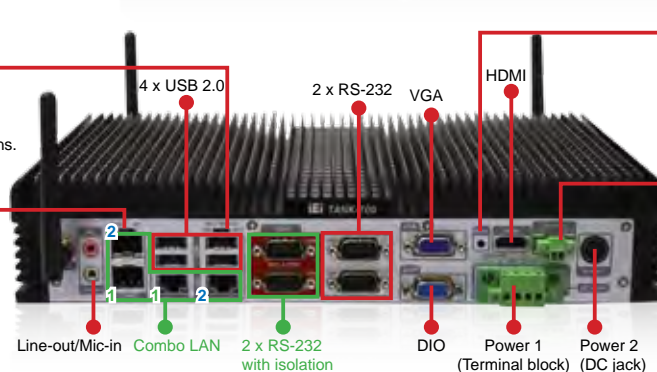

Reset
The reset button forces the system to be reset when system hangs up.

Remote control
Users can power on/off the system by inputting low or high voltage into the terminal block.
High (2 V-5 V): Power off
Low (< 0.4 V): Power on

Specifications

Model Name		TANK-700-QM67	TANK-720-Q67	
Chassis	Color	Black C + Silver	Blue C + Silver	
	Dimensions (WxDxH) (mm)	310 x 200 x 62	310 x 200 x 70	
	System Fan	Fanless	Fanless	
	Chassis Construction	Extruded aluminum alloys	Extruded aluminum alloys	
Motherboard	Processor CPU	Intel® Core™ i5-2xxE (above 2.5 GHz) Intel® Core™ i3-2xxE (above 2.2 GHz) Intel® Celeron® B8xx (above 1.6 GHz)	Intel® Core™ i5-2xxT (above 2.7 GHz) Intel® Core™ i3-2xxT (above 2.5 GHz) Intel® Pentium® G6xxT (above 2.2 GHz)	
	Chipset	Intel® QM67	Intel® Q67	
	System Memory	On-board DDR3 2 GB memory 1 x 204-pin DDR3 SO-DIMM (system max: 10 GB)	On-board DDR3 2 GB memory 1 x 204-pin DDR3 SO-DIMM (system max: 10 GB)	
Storage	Hard Drive	2 x 2.5" SATA 3Gb/s HDD/SSD bay	2 x 2.5" SATA 3Gb/s HDD/SSD bay	
	mSATA	1 x mSATA (SATA 3Gb/s signal)	1 x mSATA (SATA 3Gb/s signal)	
I/O Interfaces	USB 3.0	2	2	
	USB 2.0	4	4	
	Ethernet	2 x Combo (SFP Fiber/RJ-45) 1 x PCIe GbE by Intel® 82579 1 x PCIe GbE by Intel® 82583V	2 x Combo (SFP Fiber/RJ-45) 1 x PCIe GbE by Intel® 82579 1 x PCIe GbE by Intel® 82583V	
	Fiber	2 x Combo (SFP Fiber/RJ-45)	2 x Combo (SFP Fiber/RJ-45)	
	RS-232	4 x DB-9, 2 x RJ-45 with isolation	4 x DB-9, 2 x RJ-45 with isolation	
	RS-422/485	2 x RJ-45 with isolation	2 x RJ-45 with isolation	
	Digital I/O	8-bit digital I/O, 4-bit input/4-bit output	8-bit digital I/O, 4-bit input/4-bit output	
	CAN-bus	1 x Phoenix terminal block	1 x Phoenix terminal block	
	Display	1 x VGA, 1 x HDMI	1 x VGA, 1 x HDMI	
	Resolution	VGA: Up to 2048 x 1536@75Hz HDMI: Up to 1920 x 1200@60Hz	VGA: Up to 2048 x 1536@75Hz HDMI: Up to 1920 x 1200@60Hz	
	Audio	1 x Line-out, 1 x Mic-in	1 x Line-out, 1 x Mic-in	
	Other	Optional 4-channel audio/video input PCIe Mini Card	Optional 4-channel audio/video input PCIe Mini Card	
	Wireless	1 x 802.11a/b/g/n 3T3R (optional)	1 x 802.11a/b/g/n 3T3R (optional)	
	Expansions	PCIe Mini	3 x Full Size (One Colay mSATA)	3 x Full Size (One Co-lay mSATA)
	Power	Power Input	Terminal Block: 9 V~36 V DC DC Jack: 10.5 V~36 V DC	Terminal Block: 9 V~36 V DC DC Jack: 10.5 V~36 V DC
Power Consumption		19 V@3.3 A (Intel® Core™ i5-2540M with 4 GB DDR3 Memory)	19 V@3.1 A (Intel® Core™ i3-2100T with 4 GB DDR3 Memory)	
Reliability	Mounting	Wall mount	Wall mount	
	Operating Temperature	-20°C ~70°C with air flow (SSD), 5% ~ 95%, non-condensing	-20°C ~50°C with air flow (SSD), 5% ~ 95%, non-condensing	
	Operating Shock	Half-sine wave shock 5G, 11ms, 3 shocks per axis	Half-sine wave shock 5G, 11ms, 3 shocks per axis	
	Operating Vibration	MIL-STD-810F 514.5C-2 (with SSD)	MIL-STD-810F 514.5C-2 (with SSD)	
	Weight (Net/Gross)	3.8 kg/6.5 kg	4.2 kg/6.9 kg	
	Safety/EMC	CE/FCC	CE/FCC	
OS	Supported OS	Microsoft® Windows® Embedded Standard 7 E, Microsoft® Windows® XP Embedded	Microsoft® Windows® Embedded Standard 7 E, Microsoft® Windows® XP Embedded	

Dimensions (Unit: mm)

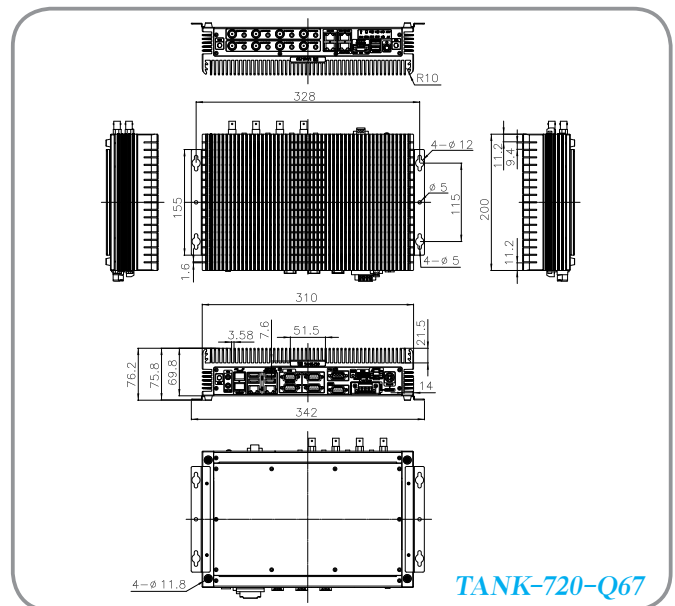
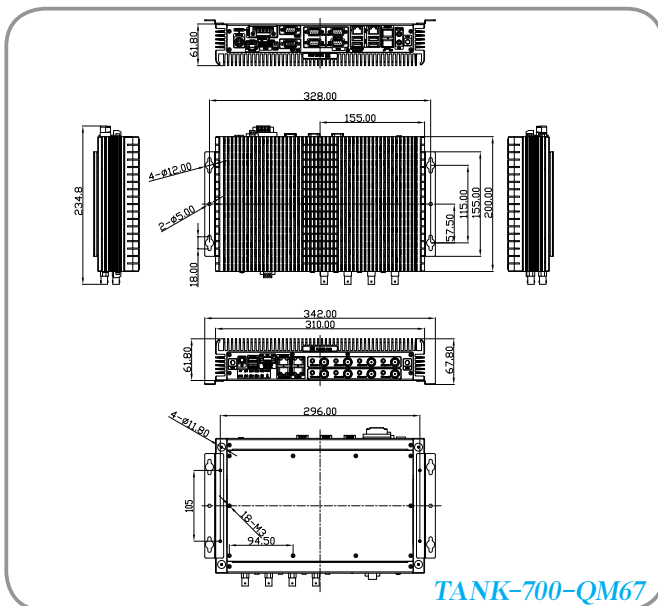

1

Industrial Computing Solutions

2

Video Capture Solutions

3

Embedded Computing Solutions

4

ORing Network Communication

5

Power Supply/ Peripherals

6

Panel Solutions Introduction

Ordering information

TANK-700 series

Part No.	Description
TANK-700-QM67-I5/2G-R21	Fanless embedded system, Core™ i5 Dual Core 2xxE CPU (Above 2.5 GHz), TDP 35W, 2GB DDR3 on-board memory, VGA/HDMI, USB 3.0, SATA 3.0, SFP Fiber, Isolated CAN, Audio, 9 V-36 V DC input, -20~70°C, R21
TANK-700-QM67W-I5/2G-R21	Fanless embedded system, Core™ i5 Dual Core 2xxE CPU (Above 2.5 GHz), TDP 35W, 2GB DDR3 on-board memory, VGA/HDMI, USB 3.0, SATA 3.0, SFP Fiber, TELEC Certified 3T3R 802.11b/g/n wireless, Isolated CAN, Audio, 9 V-36 V DC input, -20~70°C, R21
TANK-700-QM67-I3/2G-R21	Fanless embedded system, Core™ i3 Dual Core 2xxE CPU (Above 2.2 GHz), TDP 35W, 2GB DDR3 on-board memory, VGA/HDMI, USB 3.0, SATA 3.0, SFP Fiber, Isolated CAN, Audio, 9 V-36 V DC input, -20~70°C, R21
TANK-700-QM67W-I3/2G-R21	Fanless embedded system, Core™ i3 Dual Core 2xxE CPU (Above 2.2 GHz), TDP 35W, 2GB DDR3 on-board memory, VGA/HDMI, USB 3.0, SATA 3.0, SFP Fiber, TELEC Certified 3T3R 802.11b/g/n wireless, Isolated CAN, Audio, 9 V-36 V DC input, -20~70°C, R21
TANK-700-QM67-C/2G-R21	Fanless embedded system, Celeron® Dual Core B8xx CPU (Above 1.6 GHz), TDP 35W, 2GB DDR3 on-board memory, VGA/HDMI, USB 3.0, SATA 3.0, SFP Fiber, Isolated CAN, Audio, 9 V-36 V DC input, -20~70°C, R21
TANK-700-QM67W-C/2G-R21	Fanless embedded system, Celeron® Dual Core B8xx CPU (Above 1.6 GHz), TDP 35W, 2GB DDR3 on-board memory, VGA/HDMI, USB 3.0, SATA 3.0, SFP Fiber, TELEC Certified 3T3R 802.11b/g/n wireless, Isolated CAN, Audio, 9 V-36 V DC input, -20~70°C, R21

TANK-720 series

Part No.	Description
TANK-720-Q67-I5/2G-R20	Fanless embedded system, Core™ i5 Dual Core 2xxT CPU (Above 2.7 GHz), TDP 35W, 2GB DDR3 on-board memory, VGA/HDMI, USB 3.0, 2 x SATA 3.0, SFP Fiber, Isolated CAN, Audio, 9 V-36 V DC input, -20~50°C, R20, RoHS
TANK-720-Q67W-I5/2G-R20	Fanless embedded system, Core™ i5 Dual Core 2xxT CPU (Above 2.7 GHz), TDP 35W, 2GB DDR3 on-board memory, VGA/HDMI, USB 3.0, 2 x SATA 3.0, SFP Fiber, TELEC Certified 3T3R 802.11a/b/g/n wireless, Isolated CAN, Audio, 9 V-36 V DC input, -20~50°C, R20, RoHS
TANK-720-Q67-I3/2G-R20	Fanless embedded system, Core™ i3 Dual Core 2xxT CPU (Above 2.5 GHz), TDP 35W, 2GB DDR3 on-board memory, VGA/HDMI, USB 3.0, 2 x SATA 3.0, SFP Fiber, Isolated CAN, Audio, 9 V-36 V DC input, -20~50°C, R20, RoHS
TANK-720-Q67W-I3/2G-R20	Fanless embedded system, Core™ i3 Dual Core 2xxT CPU (Above 2.5 GHz), TDP 35W, 2GB DDR3 on-board memory, VGA/HDMI, USB 3.0, 2 x SATA 3.0, SFP Fiber, TELEC Certified 3T3R 802.11a/b/g/n wireless, Isolated CAN, Audio, 9 V-36 V DC input, -20~50°C, R20, RoHS
TANK-720-Q67-P/2G-R20	Fanless embedded system, Pentium® Dual Core G6xxT CPU (Above 2.2 GHz), TDP 35W, 2GB DDR3 on-board memory, VGA/HDMI, USB 3.0, 2 x SATA 3.0, SFP Fiber, Isolated CAN, Audio, 9 V-36 V DC input, -20~50°C, R20, RoHS
TANK-720-Q67W-P/2G-R20	Fanless embedded system, Pentium® Dual Core G6xxT CPU (Above 2.2 GHz), TDP 35W, 2GB DDR3 on-board memory, VGA/HDMI, USB 3.0, 2 x SATA 3.0, SFP Fiber, TELEC Certified 3T3R 802.11a/b/g/n wireless, Isolated CAN, Audio, 9 V-36 V DC input, -20~50°C, R20, RoHS

Options

Options	Part No.	Description
Gigabit Ethernet SFP Module	SFP1G-SX-I	1Gbps SFP optical transceiver, multi-mode/550m, 850nm (0°C ~ 70°C)/industrial grade (-20°C ~ 85°C)
	SFP1G-MLX-I	1Gbps SFP optical transceiver, multi-mode/2Km, 1310nm (0°C ~ 70°C)/industrial grade (-40°C ~ 85°C)
	SFP1G-LX10-I	1Gbps SFP optical transceiver, single-mode/10Km, 1310nm (0°C ~ 70°C)/industrial grade (-40°C ~ 85°C)
	SFP1G-XD70-I	1Gbps SFP optical transceiver, single-mode/50Km, 1550nm (0°C ~ 70°C)/industrial grade (-40°C ~ 85°C)
Fiber Cord	FPC-LCLC-MM3M	Optical connector LC/LC, multi-mode, diameter 62.5/125 µm, length 3m
Fiber Cord	FPC-LCLC-SS3M	Optical connector LC/LC, single-mode, diameter 9/125 µm, length 3m
OS: Win XPE (CD-ROM)	TANK-700-QM67-XPE-R10	OS Image with XPE, for TANK-700 QM67 Series, with CD-ROM, RoHS
	TANK-720-Q67-XPE-R10	OS Image with XPE, for TANK-720 Q67 Series, with DVD-ROM, R10
OS: Linux (CD-ROM)	TANK-700-QM67-LNX-R10*	OS Image with Linux for TANK-700 QM67, Debian operating system, Kernel version 2.6.26, with CD-ROM, RoHS
	TANK-720-Q67-LNX-R10*	OS Image with Linux for TANK-720 Q67, Debian operation system, Kernel version 2.6.26, with CD-ROM, R10
OS: Windows Embedded 7 (CD-ROM)	TANK-700-QM67-WES7E-R10	OS Image with Windows® Embedded Standard 7 E for TANK-700 QM67 Series, with CD-ROM, RoHS
	TANK-720-Q67-WES7E-R10	OS Image with Windows® Embedded Standard 7 E for TANK-720 Q67 Series, with DVD-ROM, R10

* it doesn't include video/audio capture card's driver

Packing list

Item	Part No.	Quantity	Description
Utility CD		1	Drivers and user manual
One Key Recovery CD	7B000-000724-RS	1	
Power Adapter	63040-010090-020-RS	1	FSP090-D2BA1, 90 V~264 V AC input, 90W, 19 V DC output, ErP, Din 4-pin
Power Cord	32702-000401-100-RS	1	1500 mm, European Standard
RJ-45 to DB-9 COM Port Cable	32005-000200-200-RS	4	Round cable, RS-232/422/485, RS-232 cable, 2, 300mm, 26AWG, (A)D-SUB 9P male, (B)RJ-45 8P8C+SHELL, RoHS
Power Cord Convert Cable	32702-000300-100-RS	1	Convert normal type cord to triangle type cord cable
Chassis Screw	44013-030041-RS	8	M3*4 chassis screws for backup
Mounting Bracket	41020-0163J4-00-RS	2	
Mounting Bracket Screws	44003-030062-RS	8	M3*6 mounting bracket screws
Wi-Fi Antenna (for Wi-Fi module only)	32505-000900-100-RS	3	External antenna
Pluggable DC-in Terminal Block	33502-000055-RS	1	4-pin
Pluggable CAN-bus Terminal Block	33502-000007-RS	1	3-pin
Pluggable Remote Control Terminal Block	33101-000422-RS	1	2-pin

1

Industrial Computing Solutions

2

Video Capture Solutions

3

Embedded Computing Solutions

4

ORing Network Communication

5

Power Supply/Peripherals

6

Panel Solutions Introduction