

# Products Change Notification

**Issue Date:** 2014/03/25

**Affected Model:** CF-1150SB-R11

Dear Partners,

iEi appreciates you daily support on IPC business.

Due to CF-1150SB-R10 module change

We would like to notify you the phase-out notice for the models and replacement model as below:

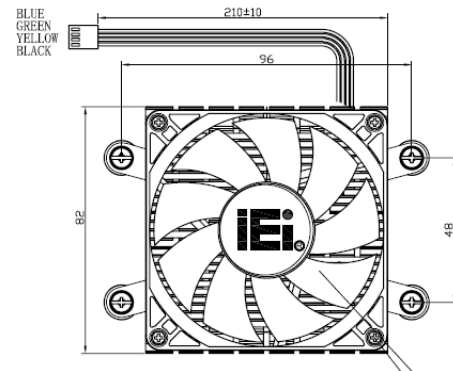
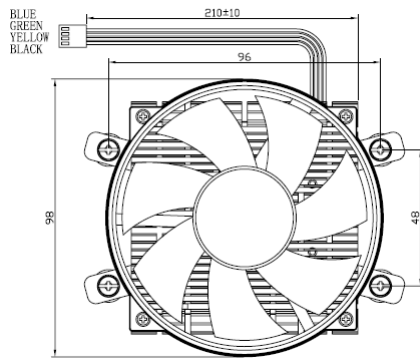

Released date	Phase-out Model	Replacement Model	Remark
2014/3/25	CF-1150SB-R10	CF-1150SB-R11	Module Change
Fan Dim	92L*92W*25H	80L*80W*20H	
Fan Speed	3500rpm	3500rpm	
Life Expectancy(hrs)	50000	50000	
Capability(Watt)	65W	65W	

Please do not hesitate to contact us while you have any further comments.

Yours Faithfully,  
 Monica Wu  
 Product Manager  
 IEI Integration corp.