



IEI Technology Corp.



MODEL:
DM Series

15"~19" LCD Monitor

VGA/DVI-D, IP 65 Protection, RoHS

User Manual

Rev. 3.00 – 7 June, 2013



Revision

Date	Version	Changes
7 June, 2013	3.00	Initial Release

Copyright

COPYRIGHT NOTICE

The information in this document is subject to change without prior notice in order to improve reliability, design and function and does not represent a commitment on the part of the manufacturer.

In no event will the manufacturer be liable for direct, indirect, special, incidental, or consequential damages arising out of the use or inability to use the product or documentation, even if advised of the possibility of such damages.

This document contains proprietary information protected by copyright. All rights are reserved. No part of this manual may be reproduced by any mechanical, electronic, or other means in any form without prior written permission of the manufacturer.

TRADEMARKS

All registered trademarks and product names mentioned herein are used for identification purposes only and may be trademarks and/or registered trademarks of their respective owners.

Table of Contents

1 INTRODUCTION.....	1
1.1 OVERVIEW.....	2
1.2 FEATURES.....	2
1.3 MODEL VARIATIONS	3
1.4 APPLICATIONS	3
1.5 EXTERNAL OVERVIEW.....	4
1.5.1 Front View.....	4
1.5.2 Bottom Panel View.....	5
1.5.3 AD Board	6
1.6 SERIES SPECIFICATIONS.....	7
1.7 CERTIFICATIONS	8
2 MECHANICAL OVERVIEW	9
2.1 INTRODUCTION.....	10
2.2 FRONT PANEL.....	10
2.2.1 Front Panel Variants.....	10
2.2.2 Front Panel Variant 1.....	10
2.2.3 Front Panel Variant 2.....	11
2.2.4 Bottom Panel.....	12
2.2.5 Available Connectors.....	12
2.3 PHYSICAL DIMENSIONS	13
2.3.1 General Physical Dimensions.....	13
2.3.2 DM-150 Physical Dimensions	14
2.3.3 DM-170 Physical Dimensions	15
2.3.4 DM-190 Physical Dimensions	16
2.3.5 Optional Mounting Kits	17
2.3.6 DM-150 Mounting Kits.....	17
2.3.7 DM-170 Mounting Kits.....	17
2.3.8 DM-190 Mounting Kits.....	18
3 LCD SPECIFICATIONS	19

3.1 LCD SPECIFICATIONS.....	20
3.1.1 LCD Overview	20
3.1.2 DM-150 LCD Specifications.....	20
3.1.3 DM-170 LCD Specifications.....	21
3.1.4 DM-190 LCD Specifications.....	21
4 AD BOARD.....	23
4.1 AD BOARD OVERVIEW.....	24
4.2 AV-6600 AD BOARD OVERVIEW	24
4.2.1 AV-6600 Peripheral Interface Connectors.....	24
4.2.2 AV-6600 Rear Panel Connectors	25
5 INSTALLATION	26
5.1 INSTALLATION PRECAUTIONS	27
5.2 UNPACKING.....	28
5.2.1 Packaging	28
5.2.2 Unpacking Procedure	28
5.2.3 Packing List	29
5.3 PRE-INSTALLATION PREPARATION	29
5.3.1 Tools.....	29
5.3.2 Voltage Select Jumper Settings	30
5.4 CONNECTORS	31
5.4.1 Rear Panel Connectors Overview.....	31
5.4.2 VGA Connector.....	32
5.4.3 DVI-D Connector.....	32
5.4.4 12V Power Connector.....	33
5.4.5 RS-232 for Touch Panel Connector	33
5.4.6 USB for Touch Panel Connector.....	34
5.4.7 Optional Terminal Block.....	34
5.5 MOUNTING THE MONITOR.....	35
5.5.1 Panel Mounting.....	35
5.5.2 Cabinet and Rack Installation	38
5.5.2.1 Standard Cabinet and Rack Installation	39
5.5.2.2 DM-190 Cabinet and Rack Installation	41
5.5.3 Wall Mounting.....	43

5.5.4 Monitor Stand Installation.....	45
5.5.5 Monitor Arm Installation.....	47
6 ON-SCREEN-DISPLAY (OSD) CONTROLS	48
6.1 USER MODE OSD STRUCTURE.....	49
6.1.1 OSD Buttons.....	49
6.1.2 OSD Menu Structure	50
6.2 USING THE OSD.....	51
6.2.1 Main Display Features.....	51
6.2.2 Color	52
6.2.3 OSD Configurations.....	53
7 SOFTWARE DRIVERS	54
7.1 INTRODUCTION.....	55
7.2 RS-232 OR USB TOUCH SCREEN	55
7.3 TOUCH PANEL DRIVER INSTALLATION.....	56
7.4 CHANGE THE TOUCH SCREEN INTERFACE	59
7.5 CALIBRATING THE TOUCH SCREEN.....	59
8 GASKET REPLACEMENT.....	62
8.1 GASKET REPLACEMENT	63
A SAFETY PRECAUTIONS	64
A.1 SAFETY PRECAUTIONS	65
A.1.1 General Safety Precautions.....	65
A.1.2 Anti-static Precautions	66
A.2 MAINTENANCE AND CLEANING PRECAUTIONS.....	66
A.2.1 Maintenance and Cleaning.....	66
A.2.2 Cleaning Tools.....	67
B CERTIFICATIONS	68
B.1 RoHS COMPLIANT	69
B.2 IP 65 COMPLIANT FRONT PANEL	69
C SMARTOSD	70
C.1 IEI SMARTOSD QUICK INSTALLATION GUIDE	71
C.2 PRE-INSTALLATION NOTICE.....	71

C.3 SMARTOSD INSTALL	71
C.4 SOFTWARE ILLUSTRATION	75
<i>C.4.1 Manage Page</i>	77
<i>C.4.2 EDID Page</i>	78
<i>C.4.3 Image Page</i>	79
<i>C.4.4 Display Page (for analog signal)</i>	80
<i>C.4.5 Color Page</i>	81
<i>C.4.6 PIP Page</i>	82
<i>C.4.7 System Page</i>	83
<i>C.4.8 About Page</i>	84
C.5 SMARTOSD FAQ.....	85
<i>C.5.1 Windows 2000 Installation Failure</i>	85
<i>C.5.2 Vista Installation Failure</i>	85
<i>C.5.3 Model Failure</i>	86
<i>C.5.4 DCC Port Failure</i>	87

List of Figures

Figure 1-1: DM Series	2
Figure 1-2: Typical Monitor Front View	5
Figure 1-3: Bottom Panel View	5
Figure 1-4: AV-6600 AD Board	6
Figure 2-1: Front Panel Variant 1	11
Figure 2-2: Front Panel Variant 2	12
Figure 2-3: DM-150 Physical Dimensions (millimeters).....	14
Figure 2-4: DM-170 Physical Dimensions (millimeters).....	15
Figure 2-5: DM-190 Physical Dimensions (millimeters).....	16
Figure 4-1: AV-6600 AD Board Overview	24
Figure 5-1: Monitor Rear Panel Connections	31
Figure 5-2: VGA Connector	32
Figure 5-3: DVI-D Connector	33
Figure 5-4: 12V Power Connector	33
Figure 5-5: RS-232 Touch Panel Connector	34
Figure 5-6: USB Touch Panel Connector	34
Figure 5-7: Terminal Block	35
Figure 5-8: DM-150 Panel Opening (Unit: mm).....	36
Figure 5-9: DM-170 Panel Opening (Unit: mm).....	36
Figure 5-10: DM-190 Panel Opening (Unit: mm).....	37
Figure 5-11: Insert the Monitor	37
Figure 5-12: Panel Mounting Clamp Position	38
Figure 5-13: Secure the Cabinet/Rack Bracket.....	40
Figure 5-14: Install into a Cabinet/Rack	40
Figure 5-15: Rack Mounting Nuts and Bolts Installation (DM-190)	41
Figure 5-16: Rack Mounting Bracket Installation (DM-190).....	42
Figure 5-17: Rack Mounting (DM-190)	42
Figure 5-18: Wall-mounting Bracket	43
Figure 5-19: Monitor Support Screws.....	44
Figure 5-20: Wall Mounting the Monitor	45

Figure 5-21: VESA Mounting Holes	46
Figure 5-22: Monitor Stand Mounting.....	46
Figure 5-23: Monitor Arm Mounting.....	47
Figure 6-1: OSD Control Buttons	49
Figure 6-2: Main Display Features	51
Figure 6-3: Color Options	52
Figure 6-4: OSD Configurations Menu	53
Figure 7-1: Setup Icon	56
Figure 7-2: Welcome Screen	57
Figure 7-3: License Agreement	57
Figure 7-4: Initiate Install	58
Figure 7-5: Installation Starts	58
Figure 7-6: Finish Installation.....	59
Figure 7-7: PenMount Monitor Icon	60
Figure 7-8: PenMount Monitor Popup Menu.....	60
Figure 7-9: Configuration Screen.....	60
Figure 7-10: Calibration Initiation Screen	61
Figure 7-11: Calibration Screen	61
Figure 8-1: Gasket Replacement.....	63
Figure 8-2: smartOSD Installer.....	72
Figure 8-3: smartOSD Welcome Screen.....	72
Figure 8-4: smartOSD Folder Select Screen.....	73
Figure 8-5: smartOSD Confirm Installation.....	73
Figure 8-6: smartOSD Installation Progress.....	74
Figure 8-7: smartOSD Installation Complete	74
Figure 8-8: Manage Page	77
Figure C-9: DLL Missing	85
Figure C-10: Windows Vista Error	85
Figure C-11: Install as Administrator.....	86
Figure C-12: Firmware Incompatibility	86
Figure C-13: DCC Port Failure.....	87

List of Tables

Table 1-1: DM Series Model Variations	3
Table 1-2: DM Series Specifications	8
Table 2-1: Front Panel Variants.....	10
Table 2-2: General Physical Dimensions	13
Table 2-3: DM-150 Mounting Kits	17
Table 2-4: DM-170 Mounting Kits	18
Table 2-5: DM-190 Mounting Kits	18
Table 3-1: DM-150 LCD Specifications	20
Table 3-2: DM-170 LCD Specifications	21
Table 3-3: DM-190 LCD Specifications	22
Table 4-1: AV-6600 Peripheral Interface Connectors.....	25
Table 4-2: AV-6600 Rear Panel Connectors.....	25
Table 5-1: Rear Panel Connectors	31
Table 5-2: VGA Connector Pinouts	32
Table 5-3: DVI-D Connector Pinouts.....	33
Table 5-4: RS-232 Touch Panel Connector Pinouts.....	33
Table 5-5: USB Touch Panel Connector Pinouts	34
Table 5-6: Panel Mounting Clamps	35
Table 6-1: OSD Menus.....	50
Table C-1: SmartOSD Menu Structure.....	76

Chapter

1

Introduction

1.1 Overview



Figure 1-1: DM Series

The DM series LCD monitor is the latest member of IEI's line of sophisticated LCD designs, and it has been improved to be RoHS compliant. It is designed to fit industrial automation, or any other applications that require minimum installation space and flexible configuration. The flat front panel provides IP 65 protection, which effectively wards off dust and water. Flexible analog or digital interfaces are provided for ease of connection with a management computer.

1.2 Features

The DM series have the following standard features:

- IP 65 compliant aluminum front panel
- Analog VGA interface supports most general system boards
- Over 300 cd/m² high brightness LCD panel
- Analog resistive type touch panel
- Advanced thermal and air-flow design
- Supports panel, rack, wall, DIN rail, stand and arm mounting
- M models support 9~36V DC power input for mobile application
- Long product life support
- RoHS compliant

1.3 Model Variations

The DM series LCD monitor has the following three base models.

- DM-150: 15" LCD screen
- DM-170: 17" LCD screen
- DM-190: 19" LCD screen

The DM series LCD monitor base models have a variety of variants. The model variations are listed in **Table 1-1**.

Model Number	LCD	9 ~ 36V Power Input
DM-150GS/R-R30	15"	-
DM-150GMS/R-R30		Yes
DM-170GS/R-R30	17"	-
DM-170GMS/R-R30		Yes
DM-190GS/R-R30	19"	-
DM-190GMS/R-R30		Yes

Table 1-1: DM Series Model Variations

1.4 Applications

The DM series LCD monitor is designed for rigorous industrial environments where it may be exposed to both heat and moisture. Its durability and strength also makes it an ideal choice for public access computers. Some possible applications include:

- Digital surveillance
- X-ray imaging terminal
- Multimedia advertising platform
- General Computing
 - Computer-based testing center
 - General purpose information system
 - Mobile nursing station
 - Interactive education use
- Automation & Control

- Plant environment monitoring
- Factory automation HMI terminal
- Shop-floor/MES control
- Self-service Kiosk
 - Full-service receptionist kiosk
 - Hospital self-registrating terminal
 - Interactive photo kiosk
 - Video rental kiosk
 - Self-service POS terminal

1.5 External Overview

The DM series LCD monitors are durable devices that can be used in harsh industrial environments. The following sections describe the physical layout of the DM series LCD monitors.

1.5.1 Front View

The front of the DM series LCD monitor is a flat panel LCD screen surrounded by an aluminum frame. A control button panel (OSD), if available, is located either vertically on the right side of the frame or horizontally along the bottom of the frame with the following control buttons:

- LCD On/Off
- Auto
- Left
- Right
- Menu

The OSD panel also has one power LED.

Figure 1-2 shows a typical monitor front view.

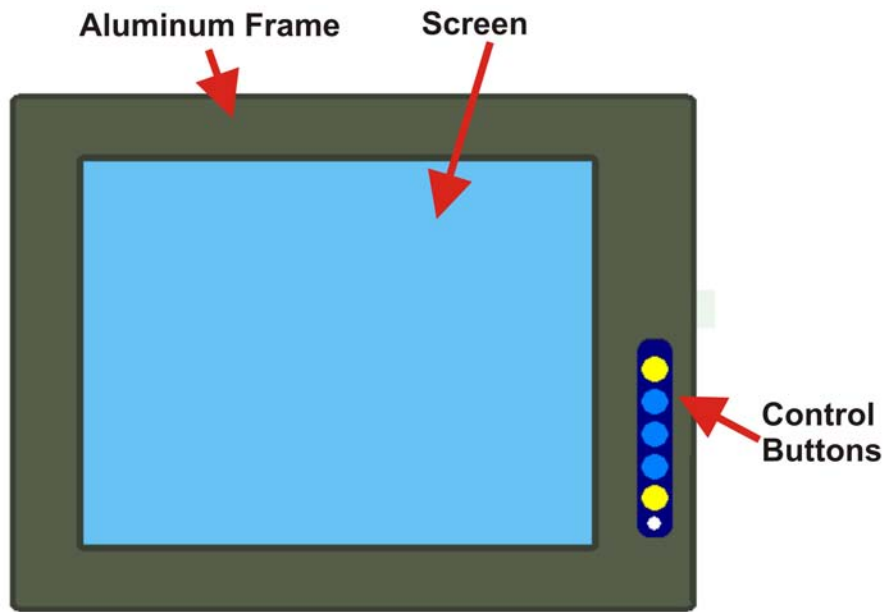

Figure 1-2: Typical Monitor Front View

1.5.2 Bottom Panel View

Figure 1-3 shows the bottom panel of the DM series LCD monitor. All connectors are fully described in Section 5.4.

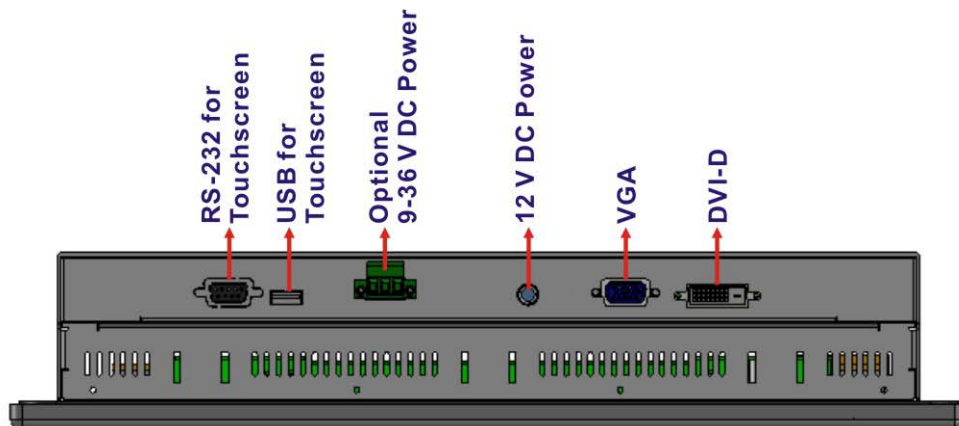

Figure 1-3: Bottom Panel View

1.5.3 AD Board

The DM series LCD monitor AD board provides a wide variety of control interfaces, receiving and managing signals from a CPU card through cabling. **Figure 1-4** shows the AV-6600 AD board as a sample of a typical AD board for the DM series LCD monitor. Refer to **Chapter 4** for a complete description of AD boards and their connectors.

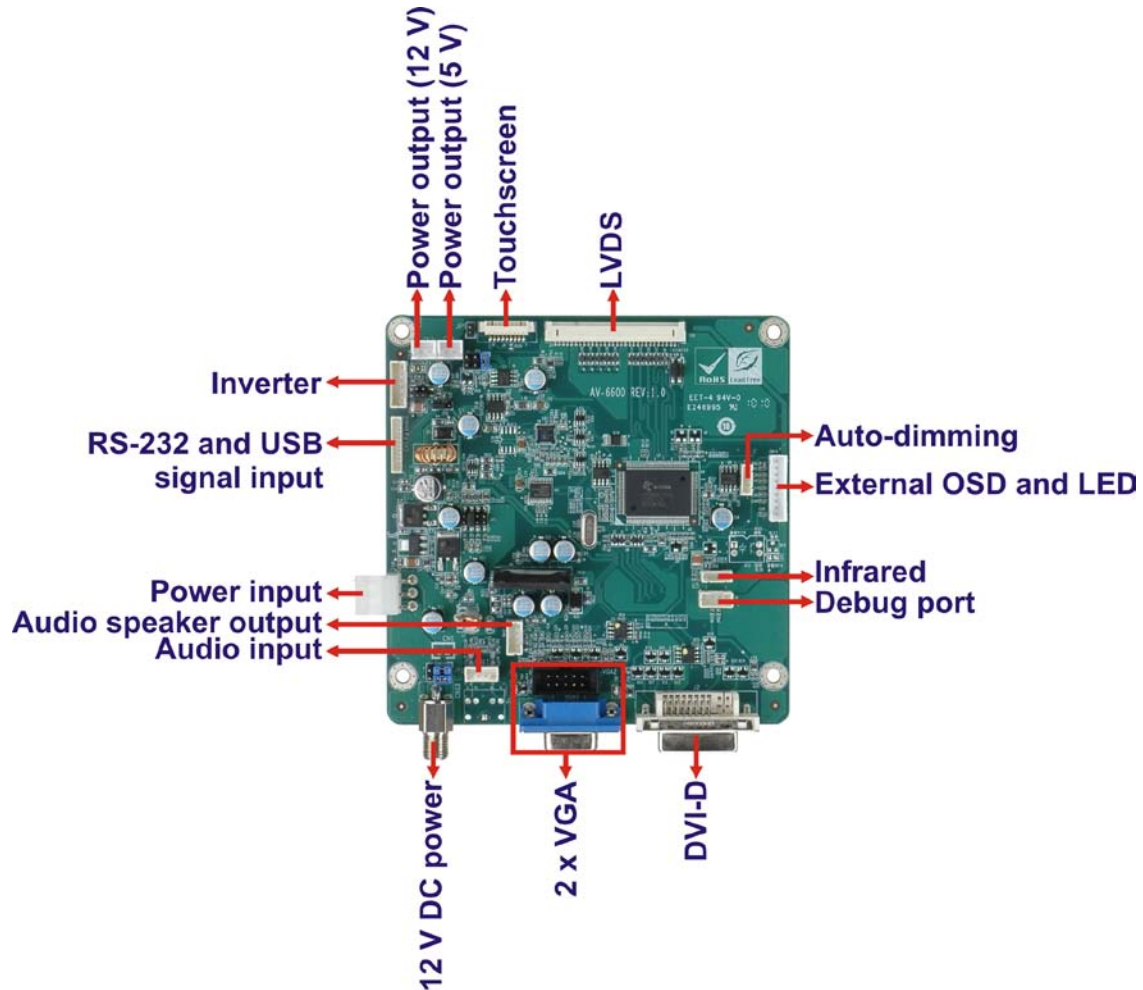

Figure 1-4: AV-6600 AD Board

1.6 Series Specifications

Table 1-2 shows the DM Series specifications.

Model	DM-150GS	DM-150GMS	DM-170GS	DM-170GMS	DM-190GS	DM-190GMS
LCD Size	15"	15"	17"	17"	19"	19"
Resolution	1024x768	1024x768	1024x768	1024x768	1024x768	1024x768
Brightness (cd/m ²)	400	400	350	350	350	350
Contrast Ratio	700:1	700:1	800:1	800:1	1000:1	1000:1
LCD Color	16.2M	16.2M	16.7M	16.7M	16.7M	16.7M
Pixel Pitch (mm)	0.297	0.297	0.264	0.264	0.264	0.264
Viewing Angle (H/V)	160/140	160/140	170/160	170/160	170/160	170/160
Touch	Resistive 5-wire USB/RS-232 interface	Resistive 5-wire USB/RS-232 interface	Resistive 5-wire USB/RS-232 interface	Resistive 5-wire USB/RS-232 interface	Resistive 5-wire USB/RS-232 interface	Resistive 5-wire USB/RS-232 interface
AD Board	AV-6600	Aluminum	AV-6600	AV-6600	AV-6600	AV-6600
Input Interface	Analog VGA + DVI-D	Analog VGA + DVI-D	Analog VGA + DVI-D	Analog VGA + DVI-D	Analog VGA + DVI-D	Analog VGA + DVI-D
OSD function	Yes	Yes	Yes	Yes	Yes	Yes
Smart-OSD	Yes	Yes	Yes	Yes	Yes	Yes
Dimension (WxHxD) (mm)	410 x 309 x 64.4	410 x 309 x 64.4	452.0 x 356.0 x 65.2	452.0 x 356.0 x 65.2	482 x 399 x 73	482 x 399 x 73
Operating Temperature	-10°C~50°C	-10°C~50°C	-10°C~50°C	-10°C~50°C	0~50°C	0~50°C
Storage Temperature	-20°C~60°C	-20°C~60°C	-20°C~60°C	-20°C~60°C	-10°C~60°C	-10°C~60°C
Net Weight	6kg	6kg	8.6kg	8.6kg	10kg	10kg
Input Voltage	12VDC	9-36VDC	12VDC	9-36VDC	12VDC	9-36VDC

Model	DM-150GS	DM-150GMS	DM-170GS	DM-170GMS	DM-190GS	DM-190GMS
Power Adapter	60W	N/A	60W	N/A	60W	N/A
Certificates	Internal Prescan EMC Class A	Internal Prescan EMC Class A	Internal Prescan EMC Class A	Internal Prescan EMC Class A	Internal Prescan EMC Class A	Internal Prescan EMC Class A

Table 1-2: DM Series Specifications

1.7 Certifications

All DM series LCD monitor models comply with the following international standards:

- RoHS
- IP 65

For a more detailed description of these standards, please refer to **Appendix B**.

Chapter

2

Mechanical Overview

2.1 Introduction

This chapter describes the general mechanical overview of the DM series monitors including front and bottom panel variations, available interfaces and overall dimensions.

2.2 Front Panel

The front panel of the DM series LCD monitor is comprised of a LCD in an aluminum frame with an OSD control panel.

2.2.1 Front Panel Variants

Table 2-1 shows the three front panel variants for the DM series LCD monitor.

Model	OSD Control Panel Location	Variant Number
DM-150, DM-170	Vertically along the right side of the aluminum frame	1
DM-190	Horizontally along the bottom of the aluminum frame	2

Table 2-1: Front Panel Variants

2.2.2 Front Panel Variant 1

The following models of the DM series LCD monitor have an OSD control panel located vertically along the right side of the aluminum frame:

- DM-150
- DM-170

Figure 2-1 shows the location of the front panel variant 1 OSD controls.

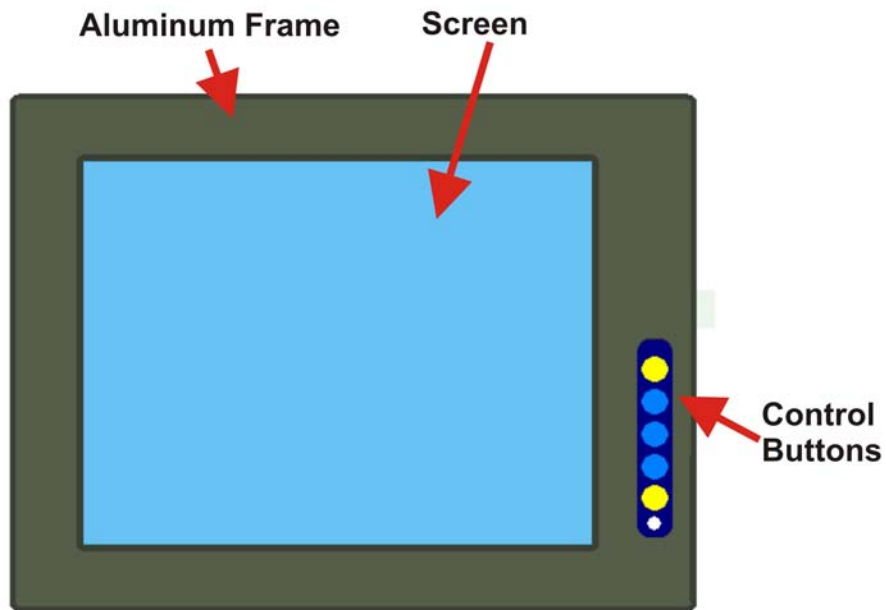

Figure 2-1: Front Panel Variant 1

2.2.3 Front Panel Variant 2

The following model of the DM series LCD monitor has an OSD control panel located horizontally along the bottom of the aluminum frame:

- DM-190

Figure 2-2 shows the location of the front panel variant 2 OSD controls.

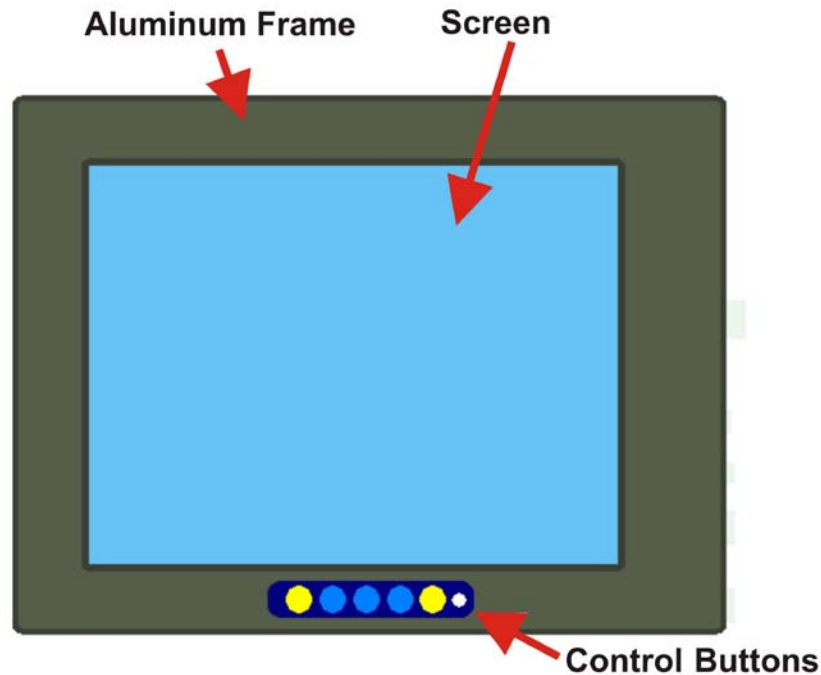

Figure 2-2: Front Panel Variant 2

2.2.4 Bottom Panel

All peripheral device connectors are located on the bottom panel of the DM series LCD monitor. The following sections describe the bottom panel variants and their associated connectors.

2.2.5 Available Connectors

There are a number of bottom panel peripheral device connectors available for the DM series LCD monitor.

- VGA connector
- DVI-D connector
- 12V power connector
- 9~36V terminal block (Optional for M model, refer to **Table 1-1**)
- RS-232 serial connector
- USB connector

2.3 Physical Dimensions

The following sections describe the physical dimensions for each model of the DM series LCD monitor.

2.3.1 General Physical Dimensions

General physical dimensions for the DM series LCD monitors are shown in **Table 2-2**.

Model	Width (mm)	Height (mm)	Depth (mm)
DM-150	410	309	64.4
DM-170	452	356	65.2
DM-190	482	399	73

Table 2-2: General Physical Dimensions

2.3.2 DM-150 Physical Dimensions

The physical dimensions of the DM-150 are shown in **Figure 2-3**.

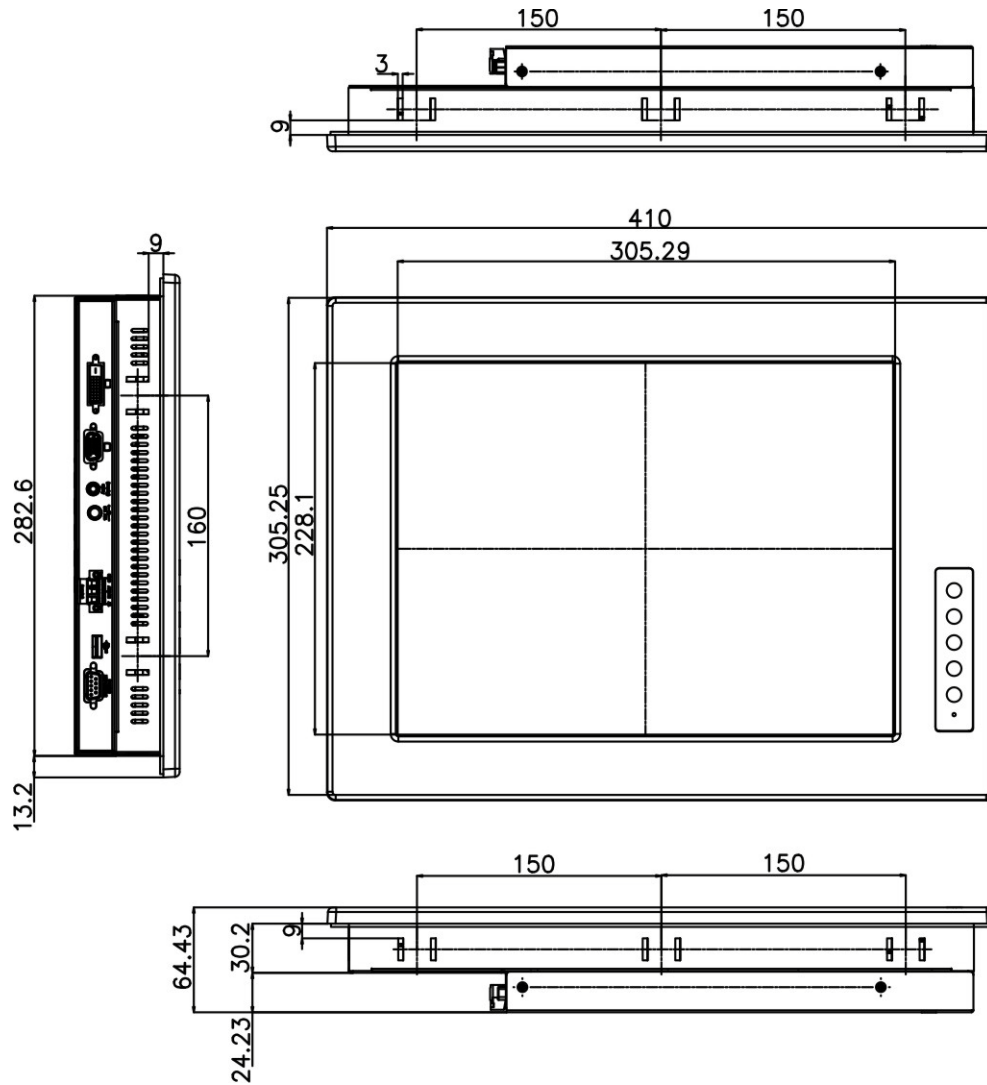

Figure 2-3: DM-150 Physical Dimensions (millimeters)

DM Series Monitor

2.3.3 DM-170 Physical Dimensions

The physical dimensions of the DM-170 are shown in **Figure 2-4**.

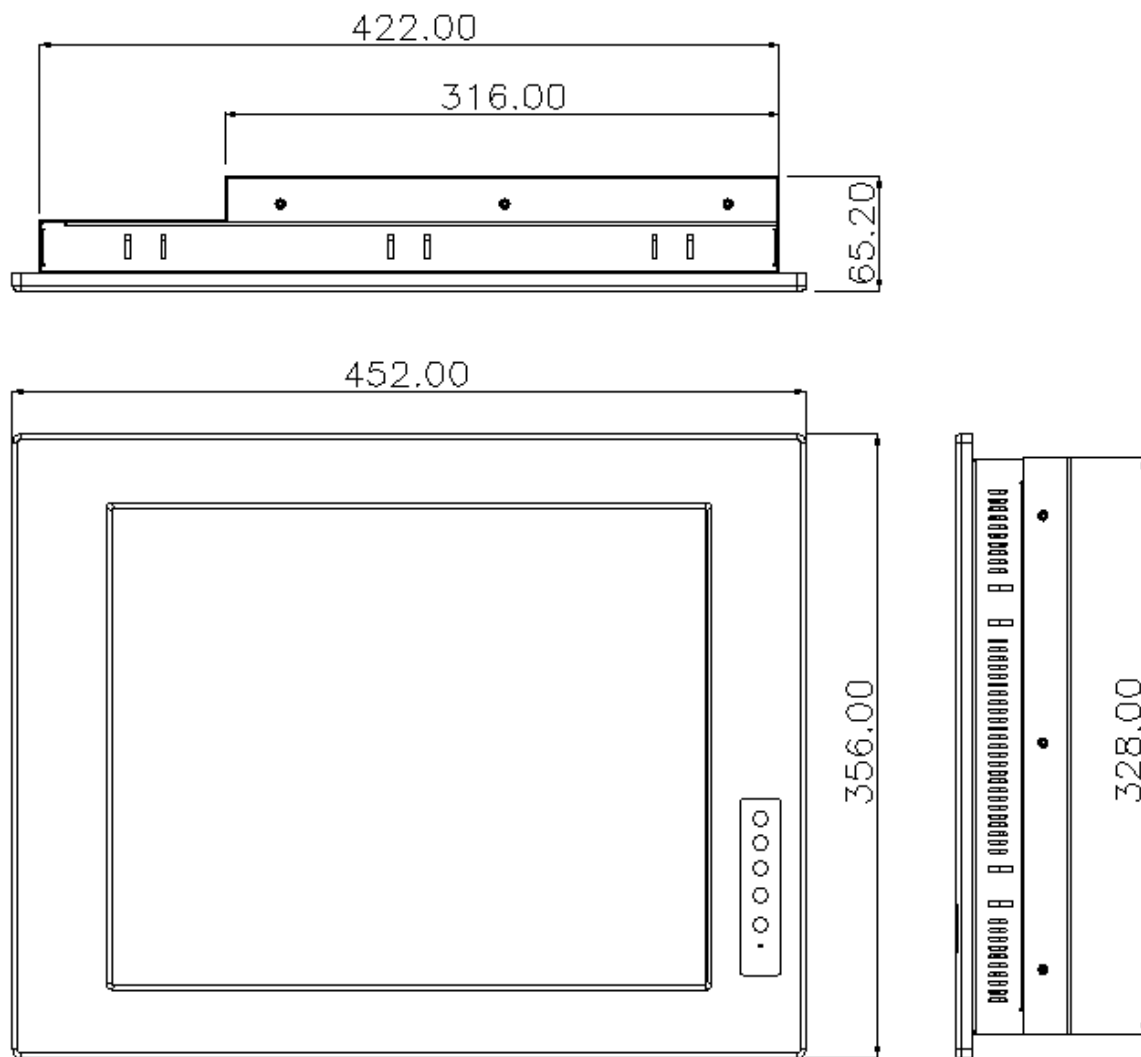

Figure 2-4: DM-170 Physical Dimensions (millimeters)

2.3.4 DM-190 Physical Dimensions

The physical dimensions of the DM-190 are shown in **Figure 2-5**.

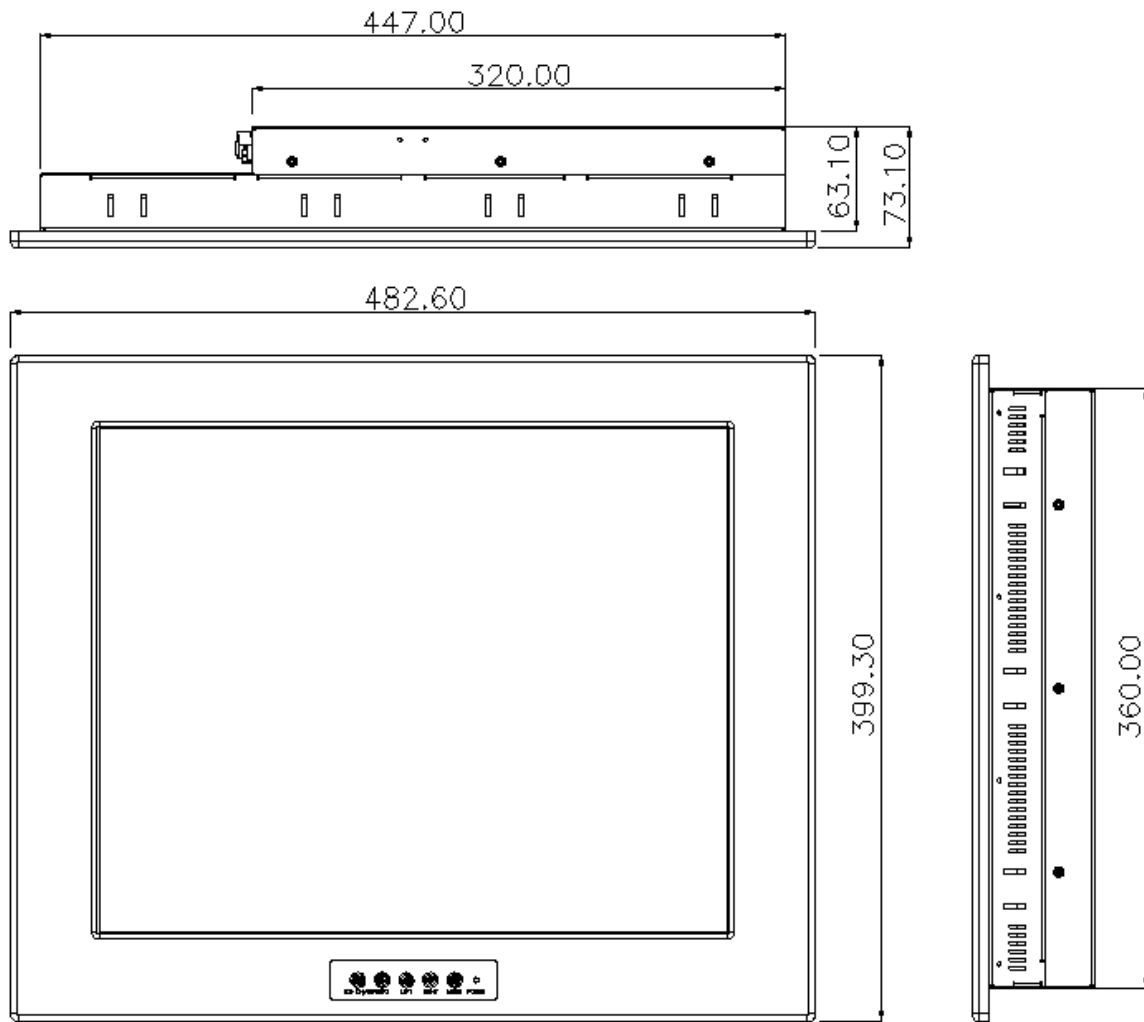

Figure 2-5: DM-190 Physical Dimensions (millimeters)

2.3.5 Optional Mounting Kits

The following sections describe the various optional mounting kits available for each model of the DM series LCD monitor. Refer to **Section 5.5** for detailed instructions on the different mounting methods for the monitors.



CAUTION:

Due to safety concerns, it is highly recommended to use the VESA mounting kits provided by IEI for wall, stand and arm mounting. If the VESA mounting kit is purchased separately, please make sure the mounting kit is UL-listed.

2.3.6 DM-150 Mounting Kits

Table 2-3 lists the mounting kits available for the DM-150 monitor.

Model	DM-150
Panel Mounting Kit	PK-150M
Rack Mounting Kit	RK-150MS-R10
Wall Mounting Kit	WK-150MS-R10
LCD Monitor Arm	ARM-31
LCD Monitor Stand	STAND-100-RS

Table 2-3: DM-150 Mounting Kits

2.3.7 DM-170 Mounting Kits

Table 2-4 lists the mounting kits available for the DM-170 monitor.

Model	DM-170
Panel Mounting Kit	PK-170M
Rack Mounting Kit	RK-170MS-R10
Wall Mounting Kit	WK-170MS-R10
LCD Monitor Arm	ARM-31

LCD Monitor Stand	STAND-100-RS
-------------------	--------------

Table 2-4: DM-170 Mounting Kits

2.3.8 DM-190 Mounting Kits

Table 2-5 lists the mounting kits available for the DM-190 monitor.

Model	DM-190
Panel Mounting Kit	PK-190M
Rack Mounting Kit	RK-190MS-R10
Wall Mounting Kit	WK-190MS-R10
LCD Monitor Arm	ARM-31
LCD Monitor Stand	-

Table 2-5: DM-190 Mounting Kits

Chapter

3

LCD Specifications

3.1 LCD Specifications

3.1.1 LCD Overview

The DM series LCD monitors use the following LCD panels.

- **DM-150:** AUO G150XG01 V3
- **DM-170:** AUO G170EG01 V1
- **DM-190:** AUO G190EG01 V1

Detailed specifications for the LCD screens are listed in the following sections.

3.1.2 DM-150 LCD Specifications

Table 3-1 lists the DM-150 LCD specifications.

Items	DM-150
Size	15"
Brand	AUO
Model	G150XG01 V3
Backlight	LED
Brightness (cd/m ²)	400
Resolution	1024 x 768
Screen Scale	4:3
Life Time	50000H
Contrast Ratio	700:1
View Angle (H/V)	160/140
Interface	1ch LVDS
Operating Temperature	-30~85°C
Active Area (mm)	304.1 x 228.1
Pixel Pitch (mm)	0.297
Display Mode	Normal White
Number of Colors	16.2M
Supply Voltage (V)	3.3

Table 3-1: DM-150 LCD Specifications

3.1.3 DM-170 LCD Specifications

Table 3-2 lists the DM-170 LCD specifications.

Items	DM-170
Size	17"
Brand	AUO
Model	G170EG01 V1
Backlight	LED
Brightness (cd/m ²)	350
Resolution	1280 x 1024
Screen Scale	4:3
Life Time	50000H
Contrast Ratio	800:1
View Angle (H/V)	170/160
Interface	2ch LVDS
Operating Temperature	-30~85°C
Active Area (mm)	337.9 x 270.3
Pixel Pitch (mm)	0.264
Display Mode	Normal White
Number of Colors	16.7M
Supply Voltage (V)	5

Table 3-2: DM-170 LCD Specifications

3.1.4 DM-190 LCD Specifications

Table 3-3 lists the DM-190 LCD specifications.

Items	DM-190
Size	19"
Brand	AUO
Model	G190EG01 V1
Backlight	LED

Brightness (cd/m ²)	350
Resolution	1280 x 1024
Screen Scale	4:3
Life Time	50000H
Contrast Ratio	1000:1
View Angle (H/V)	170/160
Interface	2ch LVDS
Operating Temperature	0~50°C
Active Area (mm)	376.32 x 301.06
Pixel Pitch (mm)	0.294
Display Mode	Normal White
Number of Colors	16.7M
Supply Voltage (V)	5

Table 3-3: DM-190 LCD Specifications

Chapter

4

AD Board

4.1 AD Board Overview

The DM series LCD monitor AD board provides a wide variety of control interfaces, receiving and managing interface signals from a CPU card through cabling. The following sections describe each AD board in detail.

4.2 AV-6600 AD Board Overview

The AV-6600 AD board provides a wide variety of control interfaces, receiving and managing interface signals from a CPU card through cabling. The following sections describe the AV-6600 AD board in detail.

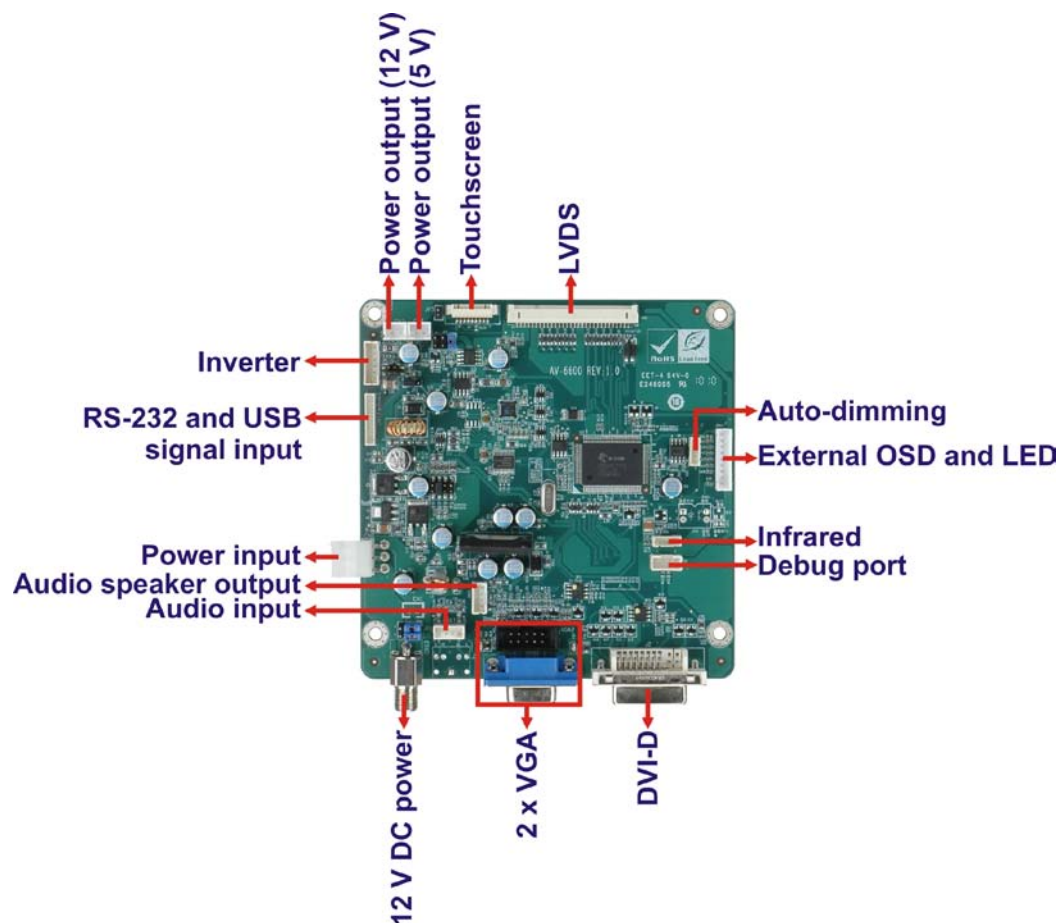

Figure 4-1: AV-6600 AD Board Overview

4.2.1 AV-6600 Peripheral Interface Connectors

Table 4-1 shows a list of the peripheral interface connectors on the AV-6600 AD board.

Connector	Type	Label
Audio input connector	4-pin wafer connector	CN11
Audio speaker output connector	4-pin wafer connector	CN12
Auto-dimming connector	6-pin wafer connector	CN7
Debug connector	4-pin wafer connector	CN9
External OSD and LED indication connector	9-pin wafer connector	CN10
Infrared connector	6-pin wafer connector	CN8
Inverter interface connector	6-pin wafer connector	CN6
LVDS connector	30-pin connector	CN5
Power output connector (+12 V)	2-pin wafer connector	CN3
Power output connector (+5 V)	2-pin wafer connector	CN4
Power input connector	3-pin connector	CN2
RS-232 and USB signal input connector	12-pin wafer connector	CN14
Touchscreen connector	9-pin wafer connector	J4
VGA connector	10-pin box header	VGA2

Table 4-1: AV-6600 Peripheral Interface Connectors

4.2.2 AV-6600 Rear Panel Connectors

Table 4-2 lists the rear panel connectors on the AV-6600 AD board.

Connector	Type	Label
12V DC power connector	DC Power Jack	CN13
DVI connector	24-pin DVI-D connector	J2
VGA connector	15-pin VGA connector	VGA1

Table 4-2: AV-6600 Rear Panel Connectors



Chapter

5

Installation

5.1 Installation Precautions

When installing the DM series LCD monitor, please follow the precautions listed below:

- **Read the user manual:** The user manual provides a complete description of the DM series LCD monitor, installation instructions and configuration options.
- **DANGER! Disconnect Power:** Power to the monitor must be disconnected when installing the DM series LCD monitor, or before any attempt is made to access the rear panel. Electric shock and personal injury might occur if the rear panel of the monitor is opened while the power cord is still connected to an electrical outlet.
- **Qualified Personnel:** The DM series LCD monitor must be installed and operated only by trained and qualified personnel. Maintenance, upgrades, or repairs may only be carried out by qualified personnel who are familiar with the associated dangers.
- **Mounting:** Since the monitor may weigh up to 10 kg (not including a swing arm or other accessories), please ensure at least two people assist with mounting the monitor.
- **Air Circulation:** Make sure there is sufficient air circulation when installing the monitor. The monitor's cooling vents must not be obstructed by any objects. Blocking the vents can cause overheating of the monitor. Leave at least 5 cm of clearance around the monitor to prevent overheating.
- **Grounding:** The monitor should be properly grounded. The voltage feeds must not be overloaded. Adjust the cabling and provide external overcharge protection per the electrical values indicated on the label attached to the back of the monitor.
- **Anti-static Discharge:** The rear panel of the monitor must to be removed to configure the monitor's AD board voltage select jumper. When doing so, be sure the monitor is disconnected from its power source and take all necessary safety precautions to avoid electrocution and static discharge to the AD board. The use of a grounded wrist strap and an anti-static work pad is recommended.

5.2 Unpacking

5.2.1 Packaging

When shipped, the DM series LCD monitor is wrapped in a plastic bag. Two polystyrene ends are placed on either side of the monitor. The monitor is then placed into a first (internal) cardboard box. This box is then sealed and placed into a second (external) cardboard box. The second box is also sealed. A bag containing accessory items is placed underneath the monitor, at the bottom of the internal (first) box.

5.2.2 Unpacking Procedure

To unpack the DM series LCD monitor, follow the steps below:



WARNING:

The front side LCD screen has a protective plastic cover stuck to the screen. Only remove the plastic cover after the DM series LCD monitor has been properly installed. This ensures the screen is protected during the installation process.

- Step 1:** Use box cutters, a knife or a sharp pair of scissors that seals the top side of the external (second) box.
- Step 2:** Open the external (second) box.
- Step 3:** Use box cutters, a knife or a sharp pair of scissors that seals the top side of the internal (first) box.
- Step 4:** Lift the monitor out of the boxes.
- Step 5:** Remove both polystyrene ends, one from each side.
- Step 6:** Pull the plastic cover off the DM series LCD monitor.
- Step 7:** Make sure all the components listed in the packing list are present.

5.2.3 Packing List

All the monitors in the DM series are shipped with the following components:

- 1 x DM-150/170/190 series LCD monitor.
- 1 x AC power cable
- 1 x VGA cable
- 1 x 60W power adapter
- 5 x Replacement round head screw
- 5 x Replacement flat head screw
- 5 x Replacement wire strain band
- 1 x Touch panel RS-232 cable
- 1 x Touch panel USB cable
- 1 x Touch Pen
- 1 x Utility CD
- 1 x Power cable for terminal block (Optional for M model)

If any of these items are missing or damaged, contact the distributor or sales representative immediately.

5.3 Pre-installation Preparation

5.3.1 Tools

Before installing the DM series LCD monitor, make sure the following tools are on hand:

- **Philips (crosshead) screwdriver:** All the retention screws on the system are Philips screws.
- **Soft working mat:** When the DM series LCD monitor is installed, the screen is placed on the working surface. It is therefore important to rest the MPC industrial workstation on a soft mat that cannot damage the LCD screen on the front of the DM series LCD monitor.

5.3.2 Voltage Select Jumper Settings

If the monitor comes with both 12V and 9~36V DC power connectors, the voltage select jumper on the integrated AD board must be configured for the DC connector that is used to power the monitor. Refer to Chapter 4 for the appropriate jumper settings of each AD board.

**NOTE:**

The default voltage select jumper is configured for a 12V power source.

Do not change the jumper setting unless a 9~36V DC power connector is present on the rear panel and is to be used as the monitor's power source.

To properly set the voltage select jumper, the following steps must be completed:

- Step 1:** Use a screwdriver to remove all the screws holding the rear panel to the monitor.
- Step 2:** Remove the rear panel.
- Step 3:** Locate the voltage select jumper. (See **Chapter 4**)
- Step 4:** Use the jumper(s) to set the correct voltage input. (See **Chapter 4**)
- Step 5:** Replace the rear panel.
- Step 6:** Replace all removed screws.

5.4 Connectors

Table 5-1 lists the rear panel connectors for the DM series LCD monitors.

Connectors	DM-150	DM-170	DM-190
VGA	Yes	Yes	Yes
DVI-D	Yes	Yes	Yes
Power (12V Jack)	Yes	Yes	Yes
RS-232 for Touch Panel	Yes	Yes	Yes
USB for Touch Panel	Yes	Yes	Yes
Power (9~36V Terminal Block) (Optional for M model)	Yes	Yes	Yes

Table 5-1: Rear Panel Connectors

5.4.1 Rear Panel Connectors Overview

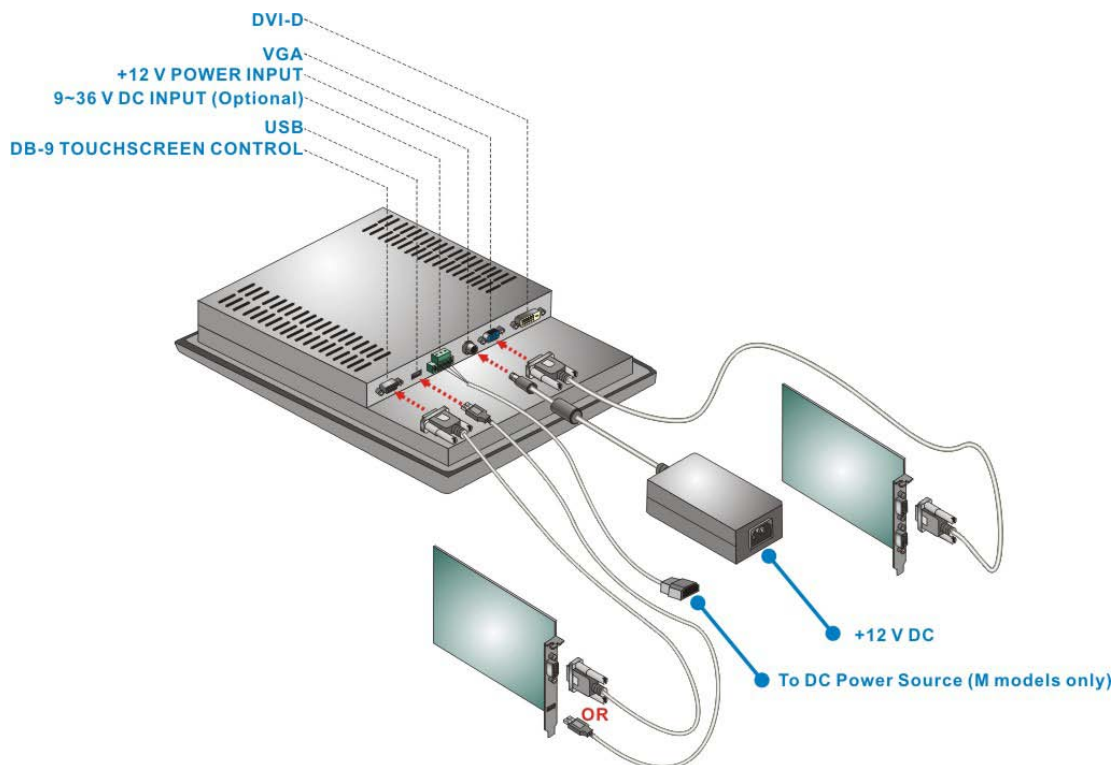

Figure 5-1: Monitor Rear Panel Connections

Figure 5-1 shows all the possible rear panel connectors for the DM series LCD monitor. Refer to **Table 5-1** for a list of the monitors and their corresponding connectors. The following sections fully describe the rear panel connectors for the DM series LCD monitor.

5.4.2 VGA Connector

Use the rear panel standard 15-pin female VGA connector to connect the monitor to the system graphics interface.

PIN	DESCRIPTION	PIN	DESCRIPTION	PIN	DESCRIPTION
1	RED	6	GROUND	11	NC
2	GREEN	7	GROUND	12	DDCDAT
3	BLUE	8	GROUND	13	HSYNC
4	NC	9	NC	14	VSYNC
5	GROUND	10	GROUND	15	DDCCLK

Table 5-2: VGA Connector Pinouts

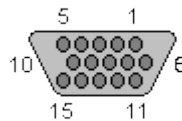

Figure 5-2: VGA Connector

5.4.3 DVI-D Connector

Use the rear panel standard 24-pin female DVI-D connector to connect the monitor to the system graphics interface.

PIN	DESCRIPTION	PIN	DESCRIPTION	PIN	DESCRIPTION
1	TMDS Data2-	9	TMDS Data1-	17	TMDS Data0-
2	TMDS Data2+	10	TMDS Data1+	18	TMDSData0+
3	TMDS Data2/4 Shield	11	TMDS Data1/3 Shield	19	TMDS Data0/5 Shield
4	TMDS Data4-	12	TMDS Data3-	20	TMDS Data5-
5	TMDS Data4+	13	TMDS Data3+	21	TMDS Data5+
6	DDC Clock [SCL]	14	+5 V Power	22	TMDS Clock Shield
7	DDC Data [SDA]	15	Ground (for +5 V)	23	TMDS Clock +

8	Analog vertical sync	16	Hot Plug Detect	24	TMD5 Clock -
---	----------------------	----	-----------------	----	--------------

Table 5-3: DVI-D Connector Pinouts

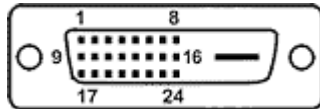

Figure 5-3: DVI-D Connector

5.4.4 12V Power Connector

Use the rear panel +12V DC jack to connect the monitor to a power source.

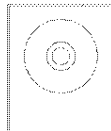

Figure 5-4: 12V Power Connector

5.4.5 RS-232 for Touch Panel Connector

Use the rear panel standard RS-232 DB-9 female touch panel connector to connect the monitor to the system graphics interface.

PIN	DESCRIPTION	PIN	DESCRIPTION
1	N/A	6	NDSR
2	NRX	7	NRTS
3	NTX	8	N/A
4	NDTR	9	N/A
5	GND		

Table 5-4: RS-232 Touch Panel Connector Pinouts

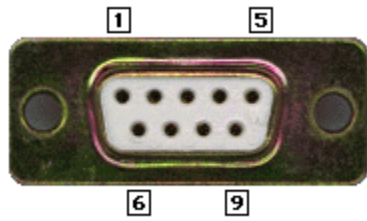

Figure 5-5: RS-232 Touch Panel Connector

5.4.6 USB for Touch Panel Connector

Use the rear panel standard USB touch panel connector to connect the monitor to the system graphics interface.

PIN	DESCRIPTION	PIN	DESCRIPTION
1	VCC	5	VCC
2	Data-	6	Data-
3	Data+	7	Data+
4	GND	8	GND

Table 5-5: USB Touch Panel Connector Pinouts



Figure 5-6: USB Touch Panel Connector

5.4.7 Optional Terminal Block

Use the rear panel 3-pin terminal block DC power connector to connect the monitor to a DC power source.

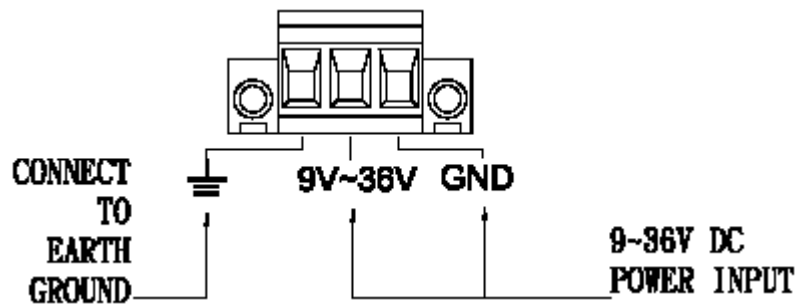

Figure 5-7: Terminal Block

5.5 Mounting the Monitor

The DM series LCD monitor can be mounted in a panel, cabinet, rack or wall. The monitor can also be mounted on a monitor arm or stand. The mounting methods are described below.



CAUTION:

When mounting the monitor take care to tighten the retention screws or bolts until fully secure, but do not over tighten. Over tightening the retention screws or bolts may cause them to become stripped, rendering them useless.

5.5.1 Panel Mounting

Each model of the DM series LCD monitor has a series of mounting slots located on the top and bottom panel for mounting the monitor to a panel.

Table 5-5 lists the number of mounting clamps required to mount the monitor to a panel.

Model	Mounting Clamps
DM-150	10
DM-170	10
DM-190	14

Table 5-6: Panel Mounting Clamps

To mount the DM series LCD monitor into a panel, please follow the steps below.

Step 1: Select the position on the panel to mount the monitor.

Step 2: Cut out a section of the panel that corresponds to the rear panel dimensions of the monitor. Take care that the panel section that is cut out is smaller than the overall size of the metal frame that surrounds the monitor but just large enough for the rear panel of the monitor to fit through.

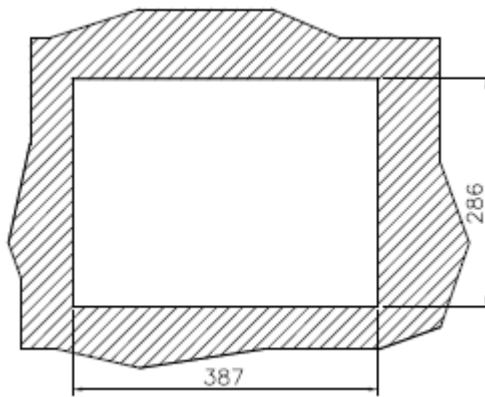

Figure 5-8: DM-150 Panel Opening (Unit: mm)

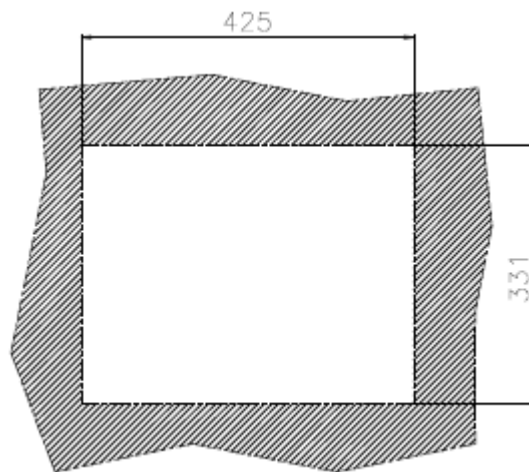

Figure 5-9: DM-170 Panel Opening (Unit: mm)

DM Series Monitor

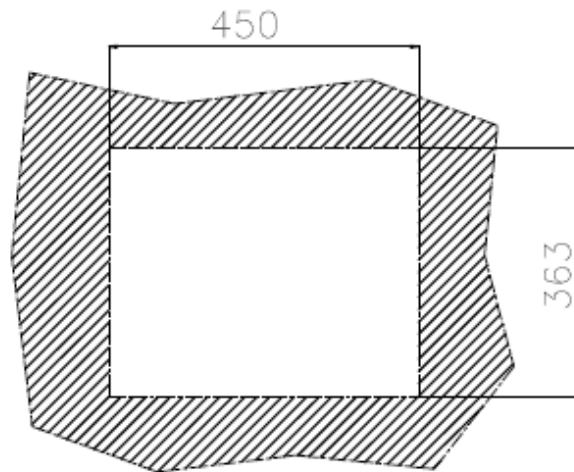

Figure 5-10: DM-190 Panel Opening (Unit: mm)

Step 3: Slide the monitor through the hole until the metal frame is flush against the panel (Figure 5-11).

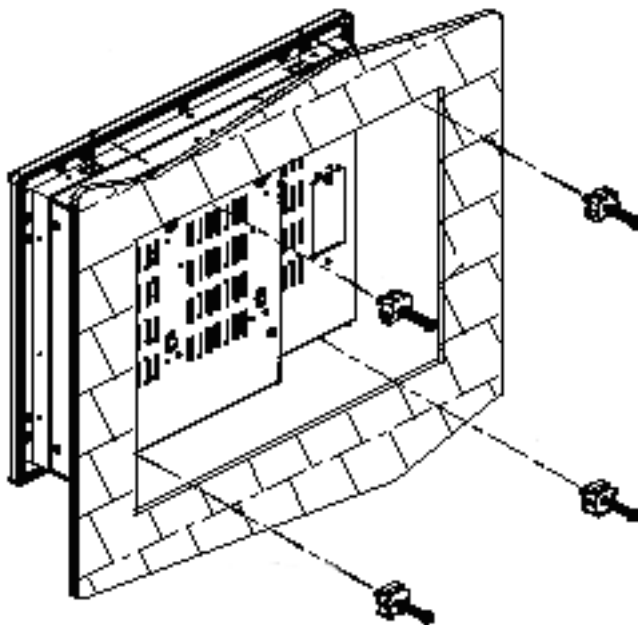

Figure 5-11: Insert the Monitor

Step 4: Insert the panel mounting clamps into the pre-formed holes along the edges of the monitor, behind the metal frame. Refer to the mounting kit packing list for the required number of mounting clamps.

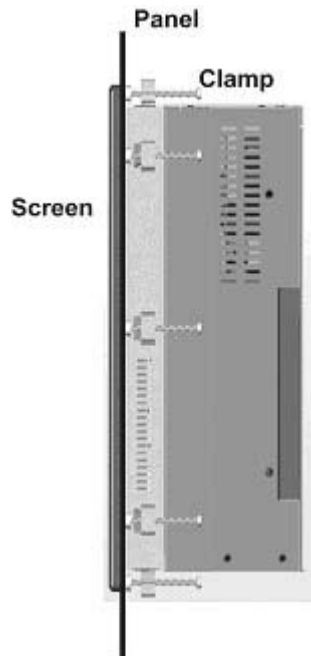

Figure 5-12: Panel Mounting Clamp Position

Step 5: Tighten the screws that pass through the panel mounting clamps until the plastic caps at the front of all the screws are firmly secured to the panel (**Figure 5-12**).

5.5.2 Cabinet and Rack Installation

Each model of the DM series LCD monitor has a series of holes located on the rear of the front panel for mounting the monitor to a rack or cabinet.



NOTE:

1. The DM-190 monitor requires two special mounting brackets for installation into a rack or cabinet. Refer to **Section 5.5.2.2** for details.

5.5.2.1 Standard Cabinet and Rack Installation

The standard cabinet/rack mounting procedure applies to the following DM series LCD monitors:

- DM-170
- DM-150

To mount the DM series LCD monitor into a cabinet/rack, please follow the steps below.

Step 1: The back of the metal frame surrounding the DM series LCD monitor has several retention screw holes for a cabinet/rack installation bracket.



NOTE:

When purchasing a cabinet/rack installation bracket, make sure it is compatible with both the monitor and the cabinet/rack into which the monitor is installed.

Step 2: Slide the monitor through the cabinet/rack bracket until the rear side of the monitor frame is flush against the front of the bracket.

Step 3: Make sure the retention screw holes at the rear of the monitor frame are aligned with the retention screw holes in the cabinet/rack bracket.

Step 4: Secure the cabinet/rack bracket to the monitor by inserting and tightening the retention screws (**Figure 5-13**).

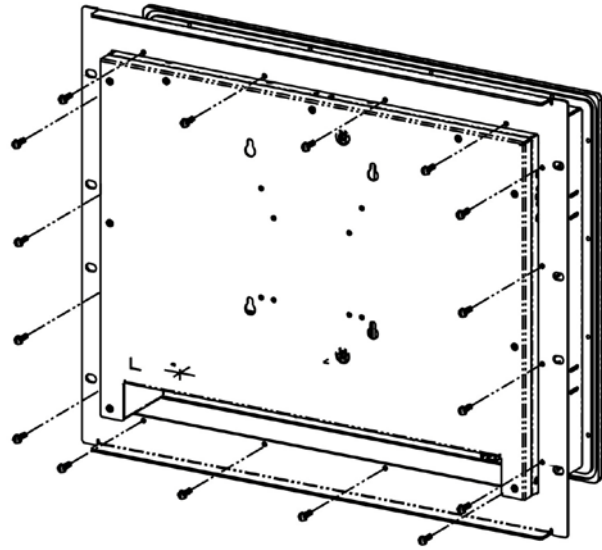

Figure 5-13: Secure the Cabinet/Rack Bracket

Step 5: Slide the monitor with the attached cabinet/rack bracket into a rack or cabinet (Figure 5-14).

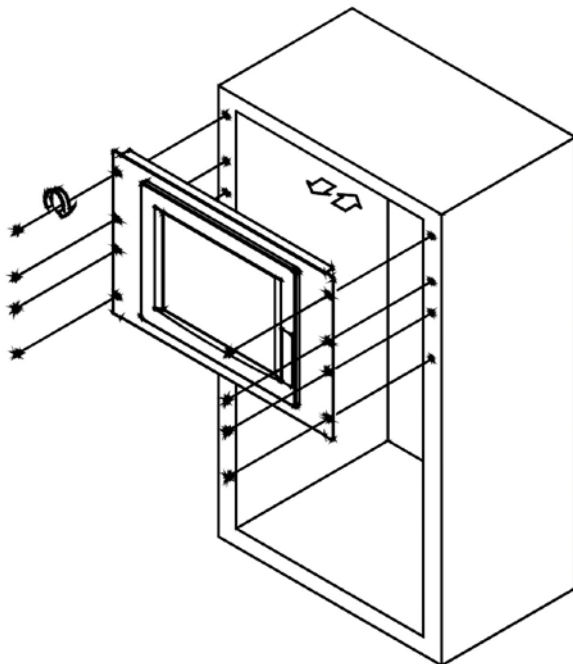

Figure 5-14: Install into a Cabinet/Rack

DM Series Monitor

Step 6: Once the monitor with the attached cabinet/rack has been properly inserted into the rack or cabinet, secure the front of the rack/cabinet bracket to the front of the rack or cabinet (**Figure 5-14**).

5.5.2.2 DM-190 Cabinet and Rack Installation

To mount the DM-190 monitor into a cabinet/rack, please follow the steps below.

Step 1: Insert and tighten the supplied mounting nuts and bolts to the rack for the rack mounting bracket. Each bracket requires three nuts and bolts for installation. (See **Figure 5-15**)

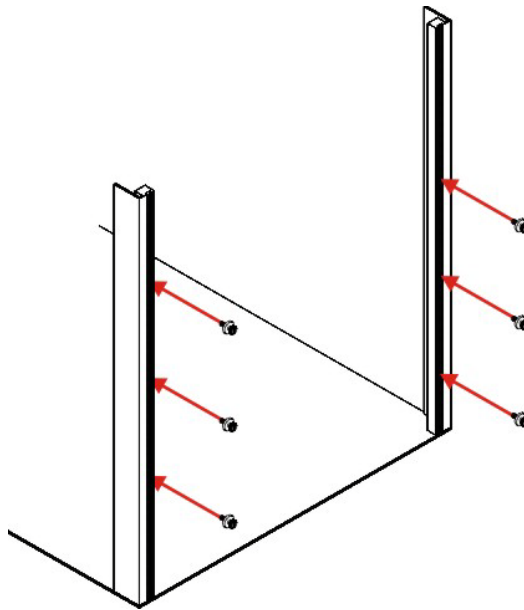

Figure 5-15: Rack Mounting Nuts and Bolts Installation (DM-190)

Step 2: Secure the rack mounting bracket to two sides of the monitor using the supplied retention screws. Each bracket requires four screws. (See **Figure 5-16**)

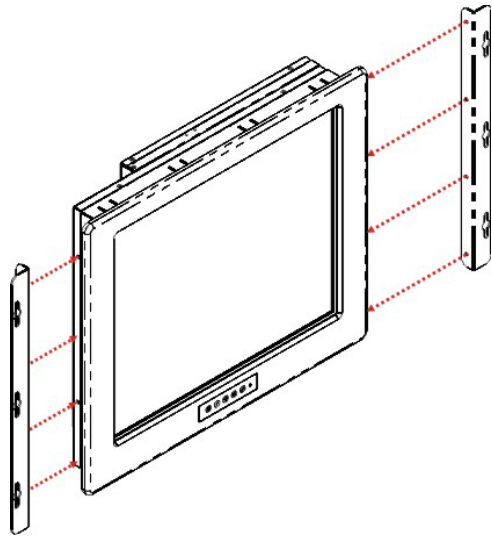

Figure 5-16: Rack Mounting Bracket Installation (DM-190)

Step 3: Carefully insert the slotted holes of the brackets on the monitor through the bolts on the rack and gently pull the monitor downwards until the bolts rest securely in the slotted holes. (See **Figure 5-17**). Ensure that all six of the bolts fit snugly into their respective slotted holes.

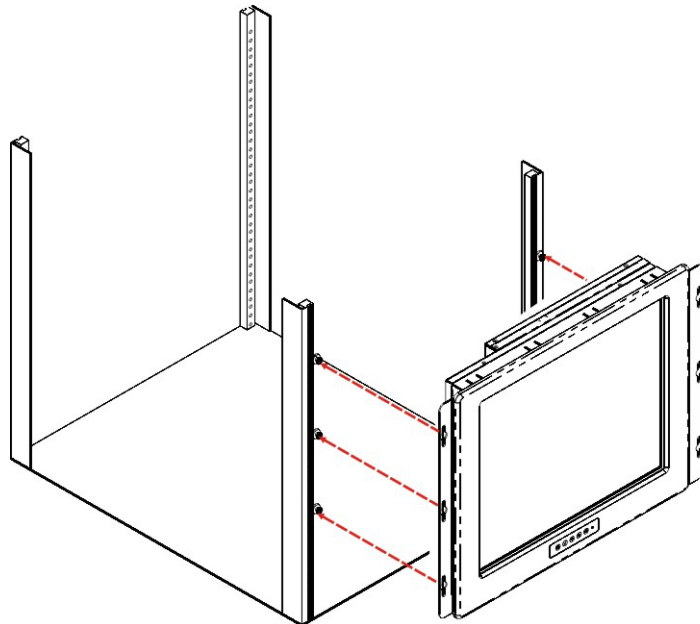

Figure 5-17: Rack Mounting (DM-190)

5.5.3 Wall Mounting

**CAUTION:**

Due to safety concerns, it is highly recommended to use the VESA mounting kits provided by IEI for wall, stand and arm mounting. If the VESA mounting kit is purchased separately, please make sure the mounting kit is UL-listed.

Each model of the DM series LCD monitor has four holes located on the rear panel for mounting the monitor to a wall. To mount the DM series LCD monitor onto a wall, please follow the steps below.

- Step 1:** Select a location on the wall for the wall-mounting bracket.
- Step 2:** Carefully mark the locations of the four bracket screw holes on the wall.
- Step 3:** Drill four pilot holes at the marked locations on the wall for the bracket retention screws.
- Step 4:** Align the wall-mounting bracket screw holes with the pilot holes.
- Step 5:** Secure the mounting-bracket to the wall by inserting the retention screws into the four pilot holes and tightening them (**Figure 5-18**).

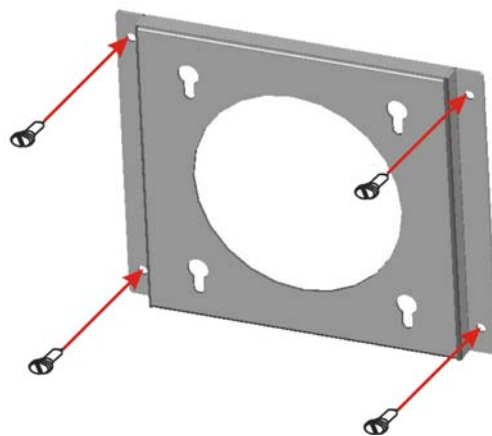

Figure 5-18: Wall-mounting Bracket

- Step 6:** Insert the four monitor mounting screws (M4 screws) provided in the wall mounting kit into the four screw holes on the rear panel of the monitor and tighten until the screw shank is secured against the rear panel (**Figure 5-19**).

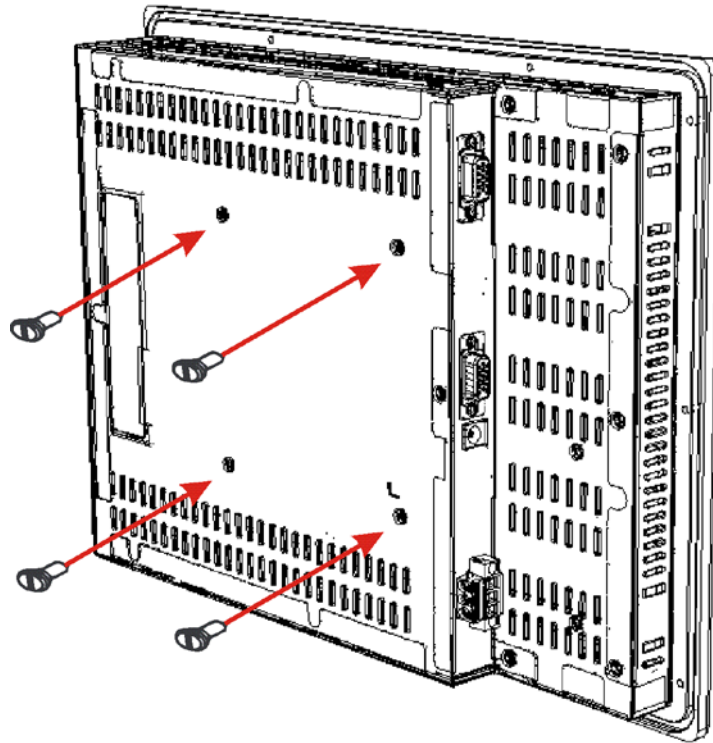

Figure 5-19: Monitor Support Screws

- Step 7:** Align the mounting screws on the monitor rear panel with the mounting holes on the bracket.
- Step 8:** Carefully insert the screws through the holes and gently pull the monitor downwards until the monitor rests securely in the slotted holes (**Figure 5-20**). Ensure that all four of the mounting screws fit snugly into their respective slotted holes.

**NOTE:**

In the diagram below the bracket is already installed on the wall.

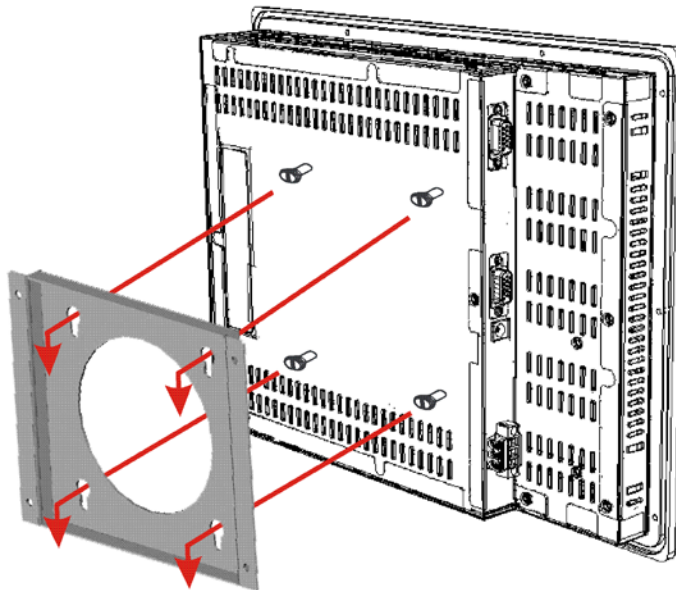

Figure 5-20: Wall Mounting the Monitor

5.5.4 Monitor Stand Installation

The DM series LCD monitor has Video Electronics Standards Association (VESA) standard mounting holes tapped into the rear panel. The standard holes are M4 set at 100m x 100mm apart (**Figure 5-21**).

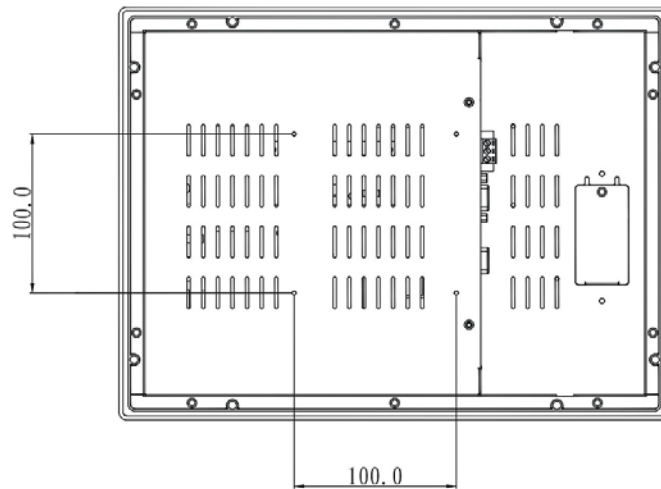

Figure 5-21: VESA Mounting Holes

The monitor stand mounting plate has a matching VESA hole pattern. To mount the DM series LCD monitor onto a stand, please follow the steps below.

- Step 1:** Line up the threaded holes on the monitor rear panel with the screw holes on the monitor stand mounting plate.
- Step 2:** Secure the monitor to the stand with the supplied retention screws (**Figure 5-22**).

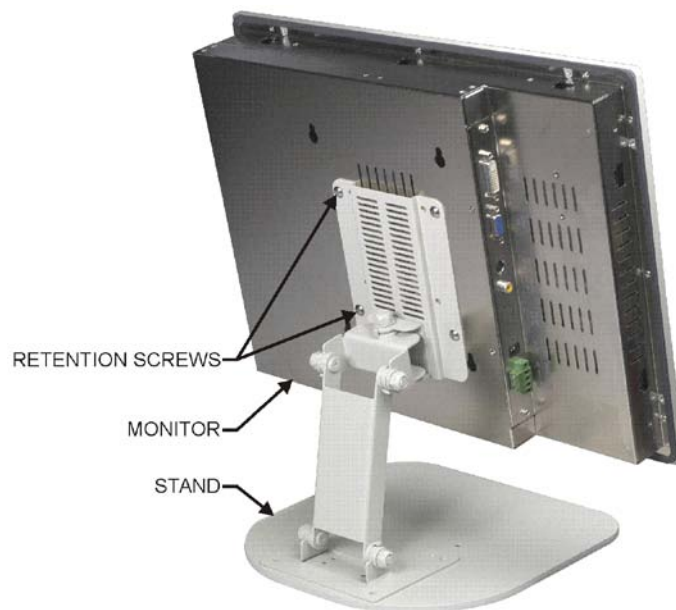

Figure 5-22: Monitor Stand Mounting

5.5.5 Monitor Arm Installation

The DM series LCD monitor has Video Electronics Standards Association (VESA) standard mounting holes tapped into the rear panel. The standard holes are M4 set at 100mm x 100mm apart (**Figure 5-21**). The monitor arm mounting plate has a matching VESA hole pattern. To mount the DM series LCD monitor onto a monitor arm, please follow the steps below.

- Step 1:** Line up the threaded holes on the monitor rear panel with the screw holes on the monitor arm mounting plate.
- Step 2:** Secure the monitor to the arm with the supplied retention screws (**Figure 5-23**).

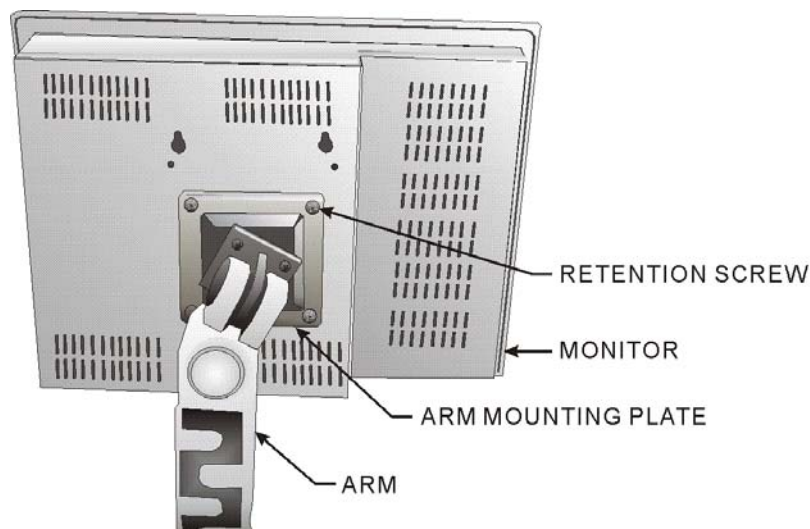

Figure 5-23: Monitor Arm Mounting



Chapter

6

On-Screen-Display (OSD) Controls

6.1 User Mode OSD Structure

6.1.1 OSD Buttons

There are several on-screen-display (OSD) control buttons oriented either vertically along the right hand side or horizontally along the bottom of the monitor front panel. Refer to **Section 2.2** for availability and orientation of the OSD controls on specific DM series monitors.

Figure 6-1 shows a typical arrangement of OSD controls of the DM series LCD monitor.

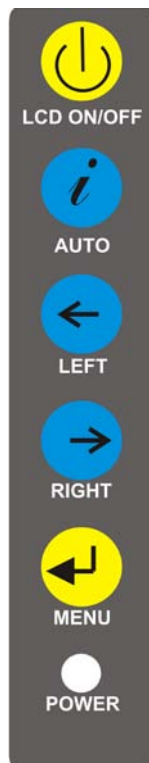

Figure 6-1: OSD Control Buttons

6.1.2 OSD Menu Structure

Table 6-1 shows the OSD menu structure for all models of the SRM series LCD monitor.

Level 0	Level 1	Value
Main Display Features Menu	Brightness	0 to 100
	Contrast	0 to 100
	Clock	0 to 100
	Phase	0 to 100
	H. Position	0 to 100
	V. Position	0 to 100
	Sharpness	1 to 5
Color Menu	6500K	- Preset NTSC value
	7500K	- Preset NTSC value
	9300K	- Preset NTSC value
	Red	RGB values from 0 to 100
	Green	RGB values from 0 to 100
	Blue	RGB values from 0 to 100
OSD Menu	OSD Time Out	0 to 60 sec
	OSD Position	1 to 5
	OSD Transparency	20, 40, 60, 80, 100
	Factory Reset	Select
	Auto Adjust	Select
	Auto Color	Select
	Gamma	Off, On
Exit Menu	Exit	Select

Table 6-1: OSD Menus

6.2 Using the OSD

OSD menu options are described below.

6.2.1 Main Display Features

Main display features are shown in **Figure 6-2**.



Figure 6-2: Main Display Features

Brightness	The brightness option adjusts the brightness of screen. This function adjusts the offset value of ADC. Setting this value too high or too low will affect the quality of image. When the auto- dimming function is turned on, the brightness control is not effective.
Contrast	This function adjusts the gain value of ADC. Adjusting this value too high or too low will worsen the quality of image.
Clock	Adjusts the width of the display screen.
Phase	Adjusts the input signal.
H. Position	Adjusts the horizontal position of the display screen.
V. Position	Adjusts the vertical position of the display screen
Sharpness	Adjust the sharpness of the display

6.2.2 Color

Color options are shown in **Figure 6-3**.

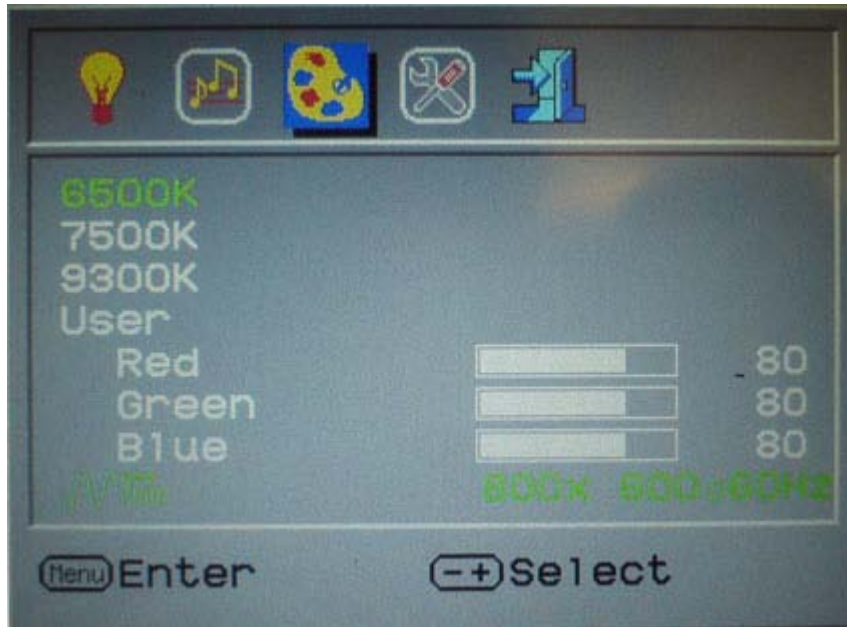

Figure 6-3: Color Options

The Color menu fine-tunes the palette of color hues for the LCD.

- | | |
|--------------|--|
| 6500k | NTSC standard Kelvin |
| 7500k | NTSC standard Kelvin |
| 9300k | NTSC standard Kelvin |
| User | This item allows fine-tuning the balance among Red, Green, and Blue color hues if images look garish or unrealistic. |

6.2.3 OSD Configurations

The OSD configurations are shown in **Figure 6-4**.



Figure 6-4: OSD Configurations Menu

OSD Configurations are described below.

- | | |
|-------------------------|--|
| OSD Time Out | Determines how many seconds the OSD screen stays on screen before it disappears when OSD is left unattended. |
| OSD Position | Adjusts the OSD position on the screen. Position 1 is in the upper left of the screen, position 2 in the upper right and position 3 in the center. |
| OSD Transparency | Adjust the transparency of the OSD menu background. |
| Factory Reset | Restores the default OSD settings. Note that this will restore all default display settings. |
| Auto Adjust | Automatically adjusts the position of the display screen |
| Auto Color | Automatically adjusts the color settings. |



Chapter

7

Software Drivers

7.1 Introduction

The touch panel controller enables analog resistive touch panels for four-wire, five-wire & eight-wire models. The controller directly communicates with the PC system through the touch panel communications interface. The controller design is superior in sensitivity, accuracy, and friendly operation. The touch panel driver emulates the left mouse button and the right mouse button functions.

The touch panel driver supports the following operating systems:

- Microsoft® Windows® versions:
 - Microsoft® Windows® 2000
 - Microsoft® Windows® XP
 - Microsoft® Windows® 2003
 - Microsoft® Windows® 2008
 - Microsoft® Windows® Vista
 - Microsoft® Windows® 7
- Microsoft® Windows® CE versions:
 - Microsoft® Windows® CE 4.2
 - Microsoft® Windows® CE 5.0
 - Microsoft® Windows® CE 6.0
- Linux Kernel 2.6
- DOS

Driver installation is described below.

7.2 RS-232 or USB Touch Screen

Before installing the driver, connect the DM Series monitor to the motherboard. The DM Series monitors support touch screen modality through an RS-232 or USB interface connection. Decide through which interface the touch screen is to be controlled.

- **RS-232 Interface:** If the touch screen interface connection is an RS-232 connection, connect the RS-232 connector on the single board computer to the DB-9 connector of the DM Series monitor.

- **USB Interface:** If the touch screen interface connection is a USB connection, connect the USB connector on the single board computer to the external USB port connector of the DM Series monitor.

7.3 Touch Panel Driver Installation



WARNING:

Before the touch screen driver is installed, make sure the system is connected to the monitor with a USB cable or an RS-232 null cable. Also, make sure the VGA connector on the system is connected to the VGA connector on the bottom of the monitor.

To install the touch panel driver for the DM Series, please follow the instructions below:

Step 1: **Connect the DM Series monitor to the single board computer.** See above.

Step 2: **Install the driver CD.** Install the driver CD into the system to which the DM Series monitor is connected.

Step 3: Select the **Touch Screen** option in the menu of driver CD. The directory in **Figure 7-1** appears.

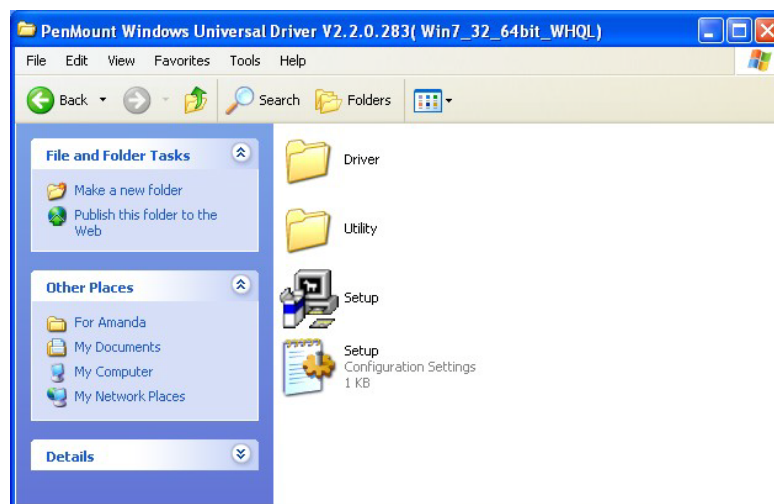

Figure 7-1: Setup Icon

DM Series Monitor

Step 4: Double click the setup icon in **Figure 7-1**.

Step 5: The Welcome screen in **Figure 7-2** appears.



Figure 7-2: Welcome Screen

Step 6: Click **Next** to continue.

Step 7: The license agreement in **Figure 7-3** appears. Accept the terms of the agreement by clicking **I Agree**.

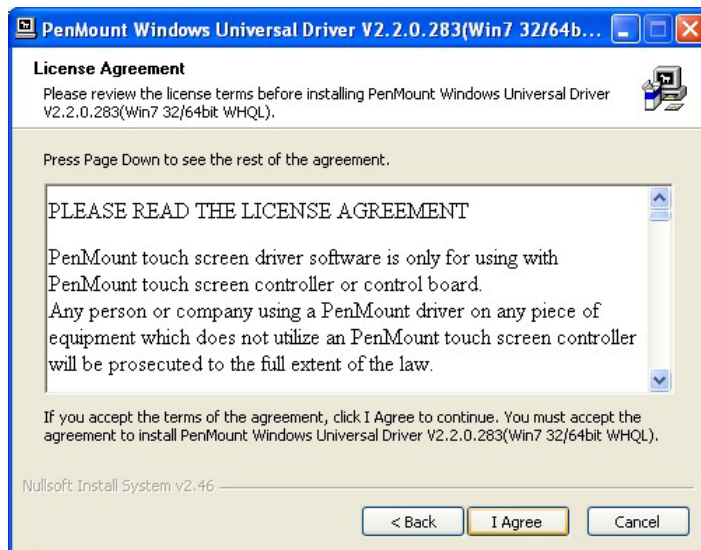

Figure 7-3: License Agreement

Step 8: The installation destination screen appears. See **Figure 7-4**. Click **Install**.

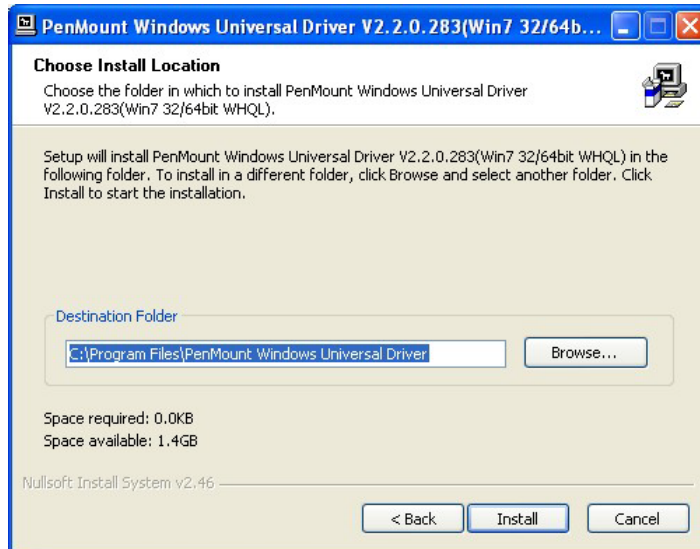

Figure 7-4: Initiate Install

Step 9: The installation of the program begins. See **Figure 7-5**.

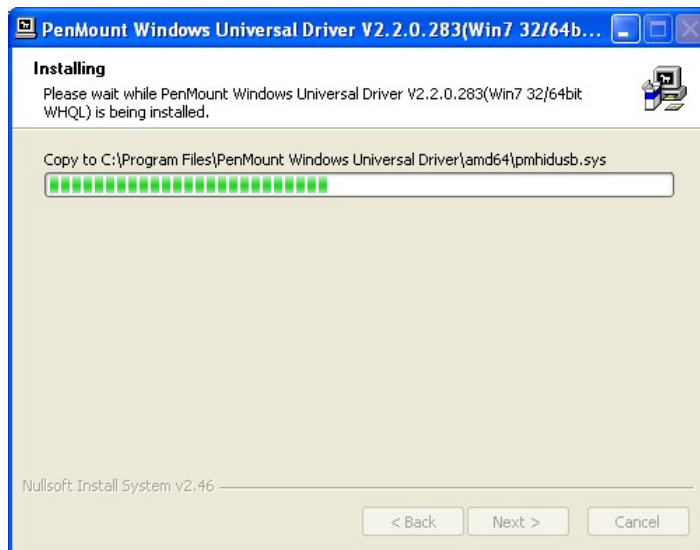

Figure 7-5: Installation Starts

Step 10: When the installation is complete, the complete screen appears. See **Figure 7-6**.

To complete the installation process click **Finish**.

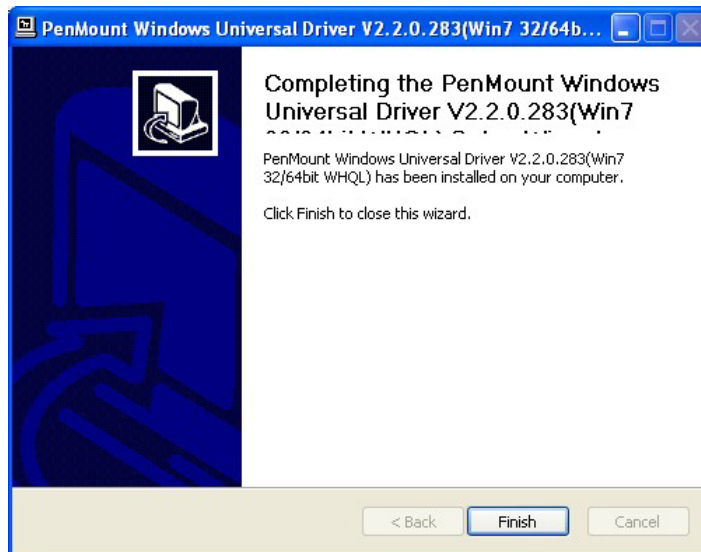

Figure 7-6: Finish Installation

7.4 Change the Touch Screen Interface

If the touch screen interface must be changed from an RS-232 interface to a USB interface or, from a USB interface to an RS-232 interface, the following steps must be followed.

- Step 1:** Uninstall the touch screen driver
- Step 2:** Remove the interface cable i.e. remove the RS-232 cable or the USB cable
- Step 3:** Install the new cable i.e. install the USB cable or the RS-232 cable.
- Step 4:** Reinstall the driver CD as described above.

7.5 Calibrating the Touch Screen

To calibrate the touch screen cursor with the motion of the touch screen pen (or finger), please follow the steps below:

- Step 1:** Make sure the system is properly connected through an RS-232 or a USB interface to the DM Series monitor.
- Step 2:** Make sure the touch screen driver is properly installed.

Step 3: Locate the PenMount Monitor icon in the bottom left corner of the screen.



Figure 7-7: PenMount Monitor Icon

Step 4: Click the icon. A pop up menu appears. See Figure 7-8.

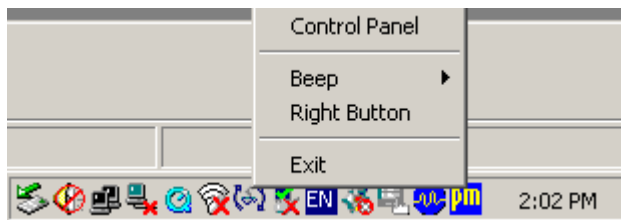

Figure 7-8: PenMount Monitor Popup Menu

Step 5: Click Control Panel in the pop up menu shown in Figure 7-8.

Step 6: The configuration screen in Figure 7-9 appears.

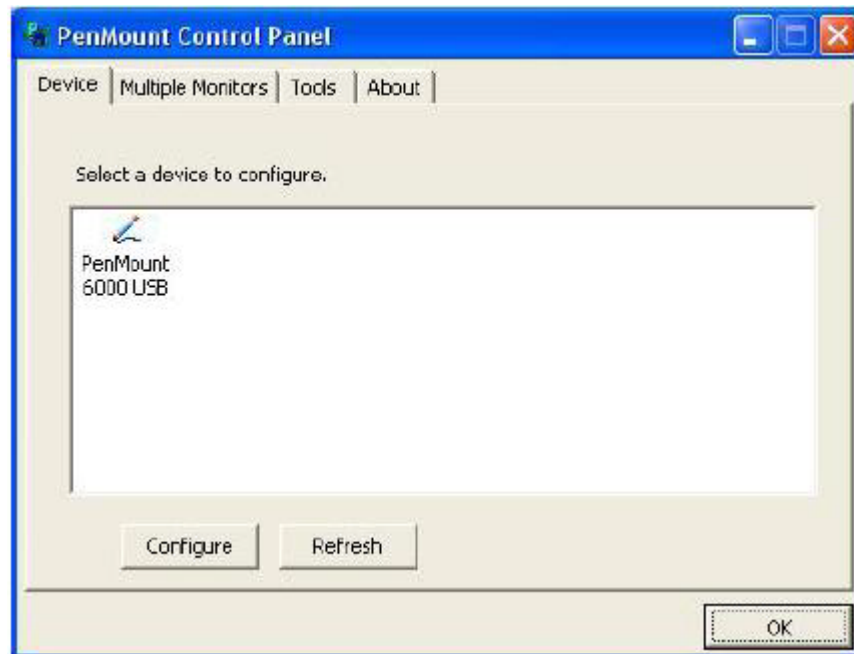

Figure 7-9: Configuration Screen

Step 7: Double click the PenMount 6000 icon as shown in **Figure 7-9**.

Step 8: The calibration initiation screen in **Figure 7-10** appears.

Step 9: Select the Standard Calibration button as shown in **Figure 7-10**.



Figure 7-10: Calibration Initiation Screen

Step 10: The calibration screen in is shown. See **Figure 7-11**.



Touch the red square.

Figure 7-11: Calibration Screen

Step 11: Follow the instructions. The user is asked touch the screen at five specified points after which the screen is calibrated.

Chapter

8

Gasket Replacement

8.1 Gasket Replacement

A gasket used for a long time may gradually lose its ability to protect the monitor from fluids and vapors; scratches or dirt may also accumulate. It is recommended that the gasket be replaced yearly.

**NOTE:**

If the monitor is mounted vertically, first remove it and place it on a flat, level surface with the display screen facing down before changing the gasket.

Step 1: Remove the old gasket from the sides of the monitor.

Step 2: Attach the new gasket to the monitor. Make sure the gasket fits precisely into the groove along the edges of the monitor's front panel (**Figure 8-1**).

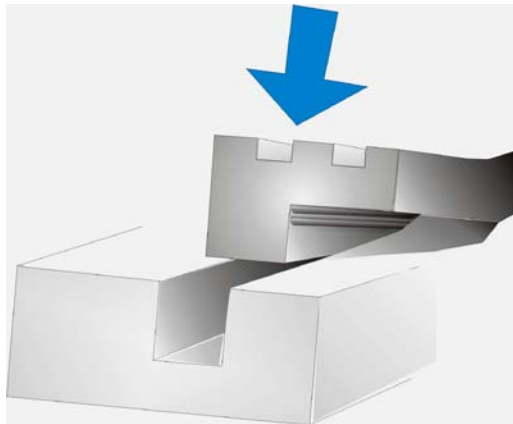

Figure 8-1: Gasket Replacement

**NOTE:**

Compliance with the IP 65 standard depends on correct installation of the gasket. Be sure to check that the gasket is properly installed after changing it.

Appendix

A

Safety Precautions

**WARNING:**

The precautions outlined in this chapter should be strictly followed. Failure to follow these precautions may result in permanent damage to the DM Series.

A.1 Safety Precautions

Please follow the safety precautions outlined in the sections that follow:

A.1.1 General Safety Precautions

Please ensure the following safety precautions are adhered to at all times.

- **Follow the electrostatic precautions** outlined below whenever the DM Series is opened.
- **Make sure the power is turned off and the power cord is disconnected** whenever the DM Series is being installed, moved or modified.
- **Do not apply voltage levels that exceed the specified voltage range.** Doing so may cause fire and/or an electrical shock.
- **Electric shocks can occur** if the DM Series chassis is opened when the DM Series is running.
- **Do not drop or insert any objects** into the ventilation openings of the DM Series.
- **If considerable amounts of dust, water, or fluids enter the DM Series**, turn off the power supply immediately, unplug the power cord, and contact the DM Series vendor.
- **DO NOT:**
 - Drop the DM Series against a hard surface.
 - Strike or exert excessive force onto the LCD panel.
 - Touch any of the LCD panels with a sharp object
 - In a site where the ambient temperature exceeds the rated temperature

A.1.2 Anti-static Precautions



WARNING:

Failure to take ESD precautions during the installation of the DM Series may result in permanent damage to the DM Series and severe injury to the user.

Electrostatic discharge (ESD) can cause serious damage to electronic components, including the DM Series. Dry climates are especially susceptible to ESD. It is therefore critical that whenever the DM Series is opened and any of the electrical components are handled, the following anti-static precautions are strictly adhered to.

- **Wear an anti-static wristband:** Wearing a simple anti-static wristband can help to prevent ESD from damaging any electrical component.
- **Self-grounding:** Before handling any electrical component, touch any grounded conducting material. During the time the electrical component is handled, frequently touch any conducting materials that are connected to the ground.
- **Use an anti-static pad:** When configuring or working with an electrical component, place it on an anti-static pad. This reduces the possibility of ESD damage.
- **Only handle the edges of the electrical component:** When handling the electrical component, hold the electrical component by its edges.

A.2 Maintenance and Cleaning Precautions

When maintaining or cleaning the DM Series, please follow the guidelines below.

A.2.1 Maintenance and Cleaning

Prior to cleaning any part or component of the DM Series, please read the details below.

- Except for the LCD panel, never spray or squirt liquids directly onto any other components. To clean the LCD panel, gently wipe it with a piece of soft dry cloth or a slightly moistened cloth.

DM Series Monitor

- The interior of the DM Series does not require cleaning. Keep fluids away from the DM Series interior.
- Be cautious of all small removable components when vacuuming the DM Series.
- Turn the DM Series off before cleaning the DM Series.
- Never drop any objects or liquids through the openings of the DM Series.
- Be cautious of any possible allergic reactions to solvents or chemicals used when cleaning the DM Series.
- Avoid eating, drinking and smoking within vicinity of the DM Series.

A.2.2 Cleaning Tools

Some components in the DM Series may only be cleaned using a product specifically designed for the purpose. In such case, the product will be explicitly mentioned in the cleaning tips. Below is a list of items to use when cleaning the DM Series.

- Cloth – Although paper towels or tissues can be used, a soft, clean piece of cloth is recommended when cleaning the DM Series.
- Water or rubbing alcohol – A cloth moistened with water or rubbing alcohol can be used to clean the DM Series.
- Using solvents – The use of solvents is not recommended when cleaning the DM Series as they may damage the plastic parts.
- Vacuum cleaner – Using a vacuum specifically designed for computers is one of the best methods of cleaning the DM Series. Dust and dirt can restrict the airflow in the DM Series and cause its circuitry to corrode.
- Cotton swabs - Cotton swabs moistened with rubbing alcohol or water are excellent tools for wiping hard to reach areas.
- Foam swabs - Whenever possible, it is best to use lint free swabs such as foam swabs for cleaning.

Appendix

B

Certifications

B.1 RoHS Compliant

All models in the DM LCD monitor series comply with the Restriction of Hazardous Materials (RoHS) Directive. This means that all components used to build the industrial workstations and the workstation itself are RoHS compliant.

The RoHS Directive bans the placing on the EU market of new electrical and electronic equipment containing more than agreed levels of lead, cadmium, mercury, hexavalent chromium, polybrominated biphenyl (PBB) and polybrominated diphenyl ether (PBDE) flame retardants.

B.2 IP 65 Compliant Front Panel

The front panels on all five models in the DM series LCD monitors have an ingress protection rating (IP) of 65, IP65. The front panels are protected from dust particles and water spray.

Appendix

C

smartOSD

C.1 IEI smartOSD Quick Installation Guide

IEI smartOSD is a proprietary On-Screen-Display (OSD) software solution from IEI that enables easy, remote monitor setting adjustments in a Windows environment. IEI smartOSD delivers excellent performance and provides more flexibility than the typical OSD hardware solutions when adjusting a monitor. smartOSD also allows monitor settings such as brightness, contrast, screen position, size, color gain to be read and changed over normal video cable (VGA or DVI). The smartOSD function is only supported by revision 1.1 models and above.

C.2 Pre-installation Notice

Before installing smartOSD software, please make sure one of the following operating systems is installed:

- Windows 95
- Windows NT 4.0
- Windows 98
- Windows 2000
- Windows 2003
- Windows XP
- Windows Vista

C.3 smartOSD Install

Connect the DM Series to a host computer. Insert the CD that came with the system and follow the instructions below.

Step 1: When the CD is installed, the screen shown in **Figure 8-2** appears.

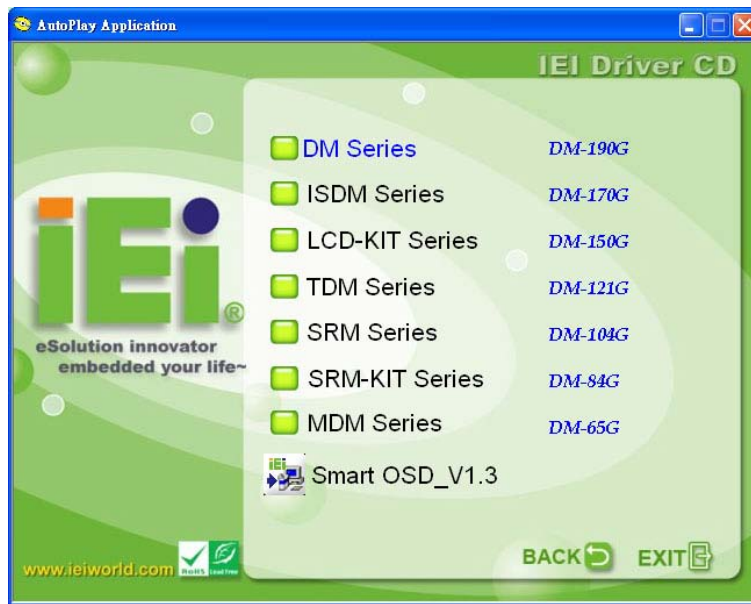

Figure 8-2: smartOSD Installer

Step 2: Click “Smart OSD” in **Figure 8-2**.

Step 3: The welcome screen shown in Figure 8-3 appears.

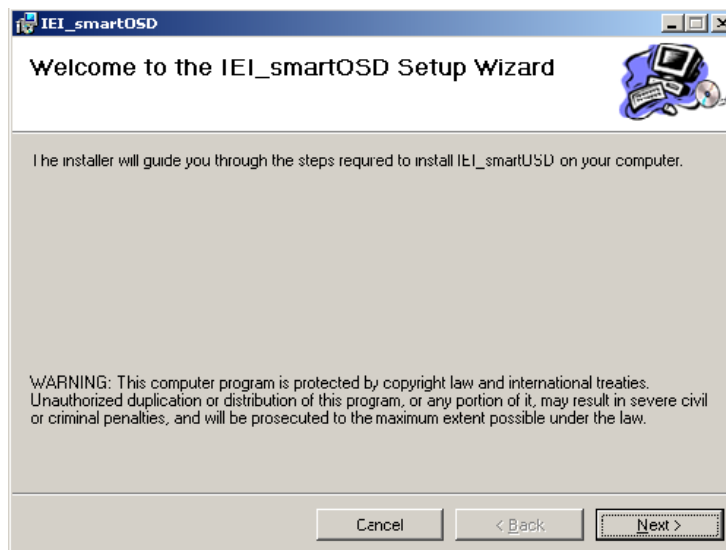

Figure 8-3: smartOSD Welcome Screen

Step 4: Click **Next** to continue.

Step 5: The Folder Select screen in **Figure 8-4** appears.

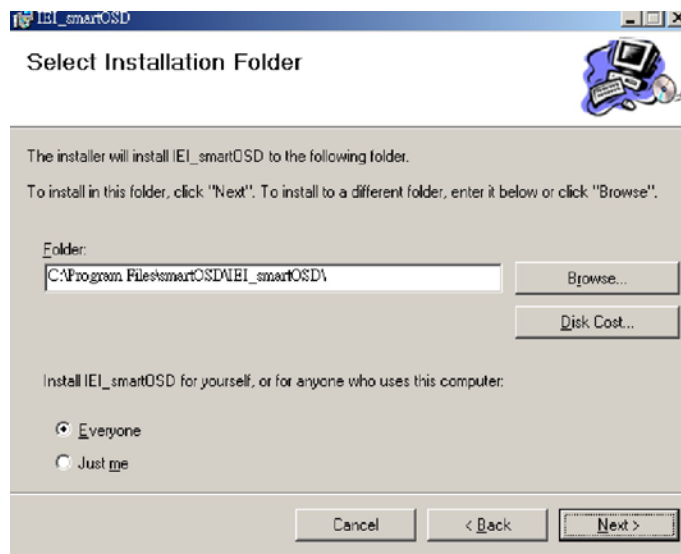

Figure 8-4: smartOSD Folder Select Screen

Step 6: Select the installation folder in Figure 8-4 shown above.

Step 7: Click **Next** to continue.

Step 8: The screen in Figure 8-5 appears.

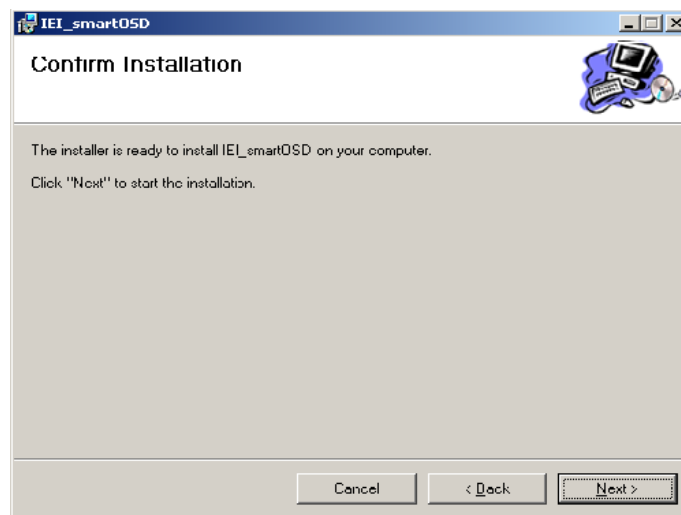

Figure 8-5: smartOSD Confirm Installation

Step 9: Confirm the installation by clicking **Next** in the screen above.

Step 10: The program starts to install and the progress bar shown in Figure 8-6 appears.

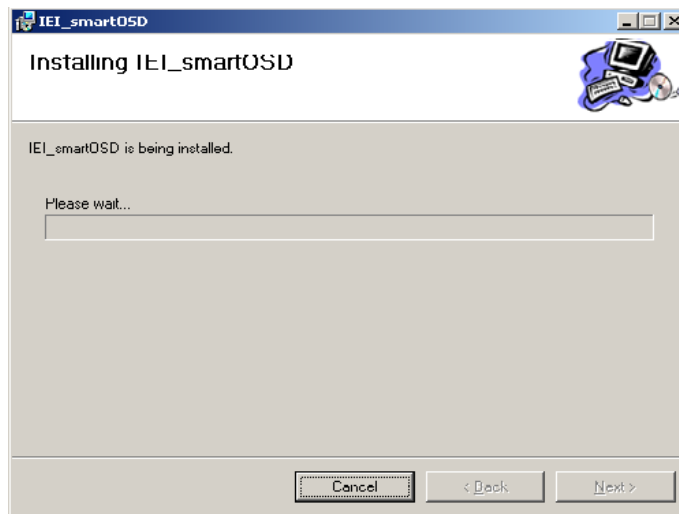

Figure 8-6: smartOSD Installation Progress

Step 11: When the installation is complete the “Complete Installation” screen in Figure 8-7 appears.

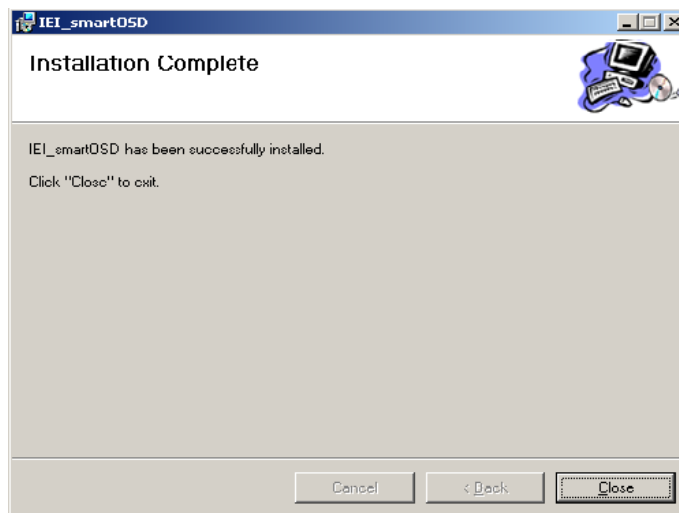

Figure 8-7: smartOSD Installation Complete

Step 12: Click **Close** in the screen above.

Step 13: After quick setup is complete, the IEI smartOSD wizard logo appears on the desktop as shown in the screen below.

Step 14: To access the smartOSD, click the smartOSD wizard logo.

DM Series Monitor

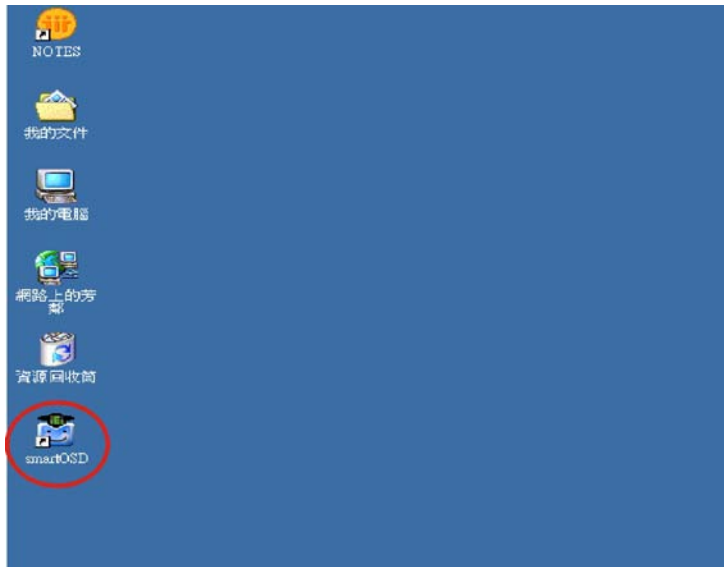

C.4 Software Illustration

The table below shows the smartOSD menu structure for all IEI LCD monitors.



NOTE:

To update the display setting status immediately, push the refresh button on every page

To turn the system on, press ALT + P.

Item	Elements
Management	Save/Load File
	Power Management
EDID	EDID contains basic information about the monitor and its capabilities.
Image	Brightness
	Contrast
	Sharpness

Display	Auto Adjust
	Phase
	Clock
Color	Auto Color
	User Red Gain
	User Green Gain
	User Blue Gain
	Color Temperature (5000k and 4200k disabled in the DM Series)
	Gamma
PIP	PIP (disabled in the DM Series)
	PIP Source Input (disabled in the DM Series)
	PIP Size (disabled in the DM Series)
System	Monitor Power Control
	Auto Brightness (disabled in the DM Series)
	Main Source Input (S-Video and CVBS disabled)
	Volume (disabled in the DM Series)
	Factory Presets/OSD Lock/OSD Unlock
	Mute (disabled in the DM Series)

Table C-1: SmartOSD Menu Structure

DM Series Monitor

C.4.1 Manage Page



Save the preferred settings of all the OSD functions as .dat files and load the settings.

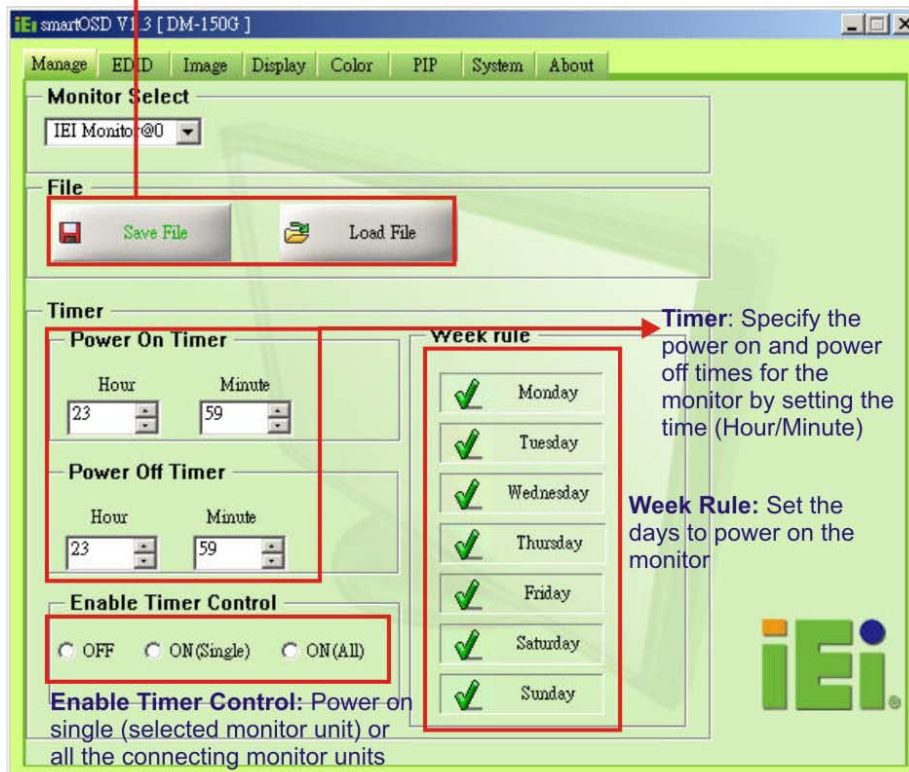

Figure 8-8: Manage Page

C.4.2 EDID Page

Caption: Shows the smartOSD version and model name.

Monitor Select: Selects the monitor unit for EDID information reading

Refresh: Updates EDID information

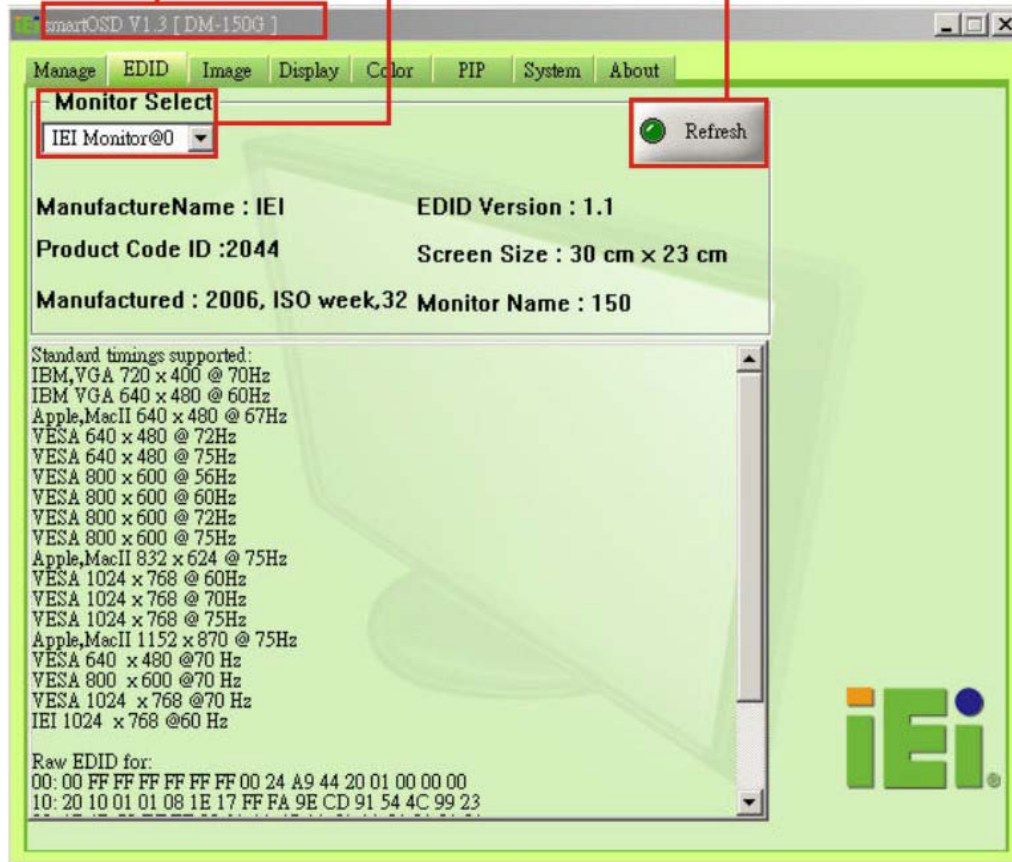

DM Series Monitor

C.4.3 Image Page

Monitor Select: Selects the monitor unit for which the image parameters will be adjusted

Refresh: To update image information which has been affected by the hardware OSD settings

Apply All: Delivering the image parameters settings to all the connecting monitors

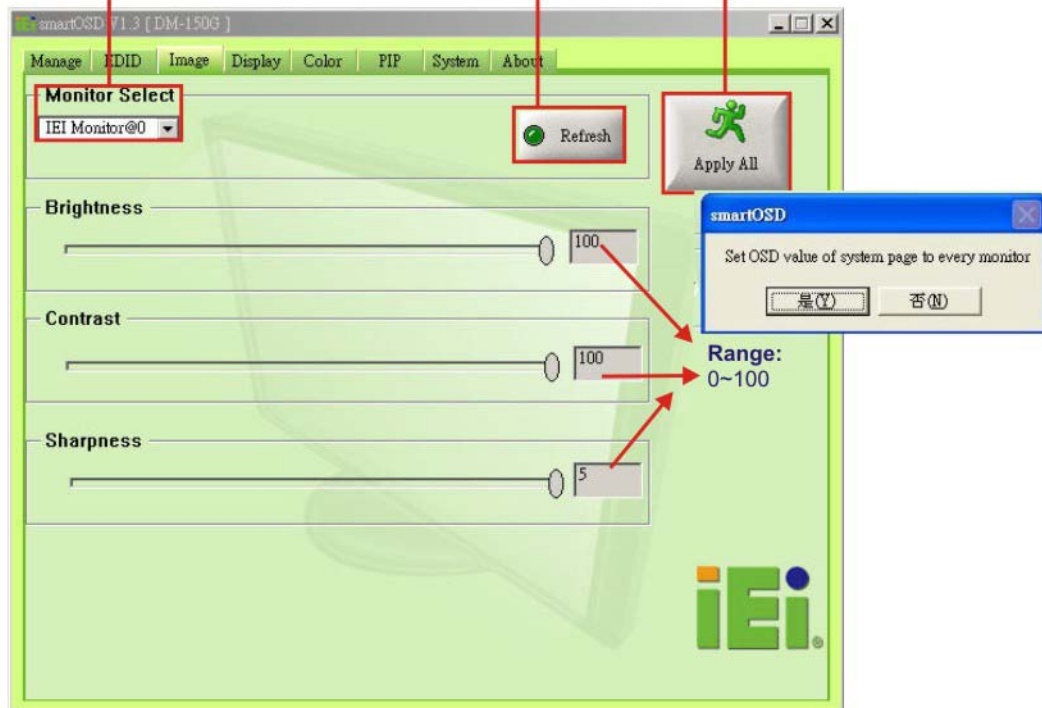

C.4.4 Display Page (for analog signal)

Apply All: Delivering the display parameters settings to all the connecting monitors

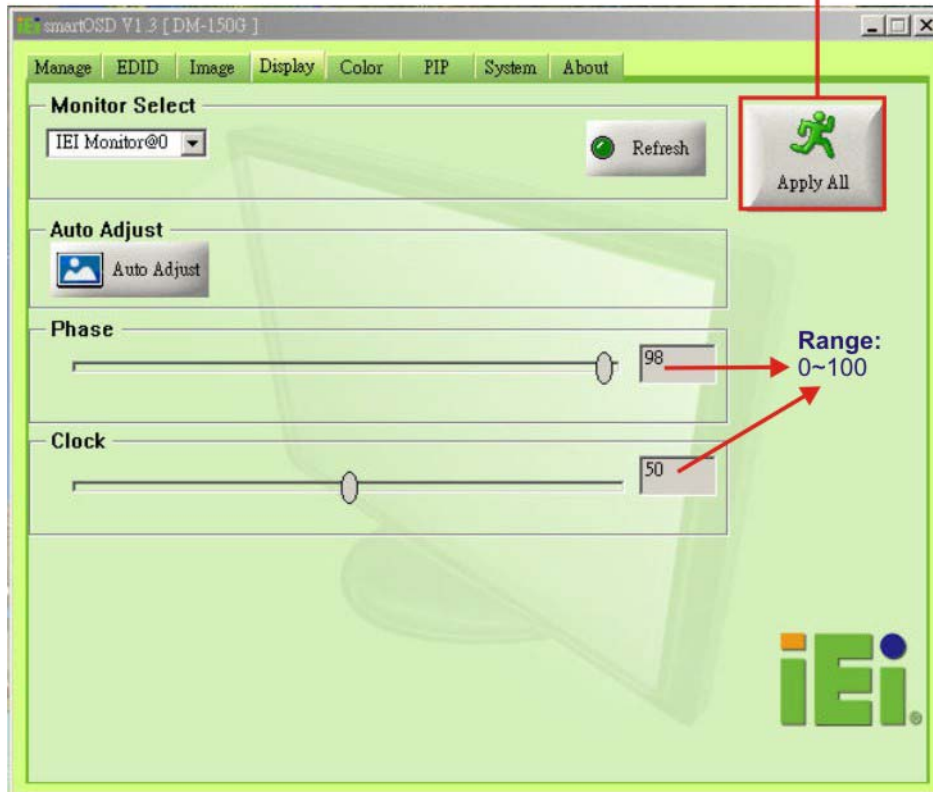

DM Series Monitor

C.4.5 Color Page

Monitor Select: Selects the monitor unit for which the image parameters will be adjusted

Refresh: To update image information which has been affected by the color OSD settings

Apply All: Delivering the color parameters settings to all the connecting monitors

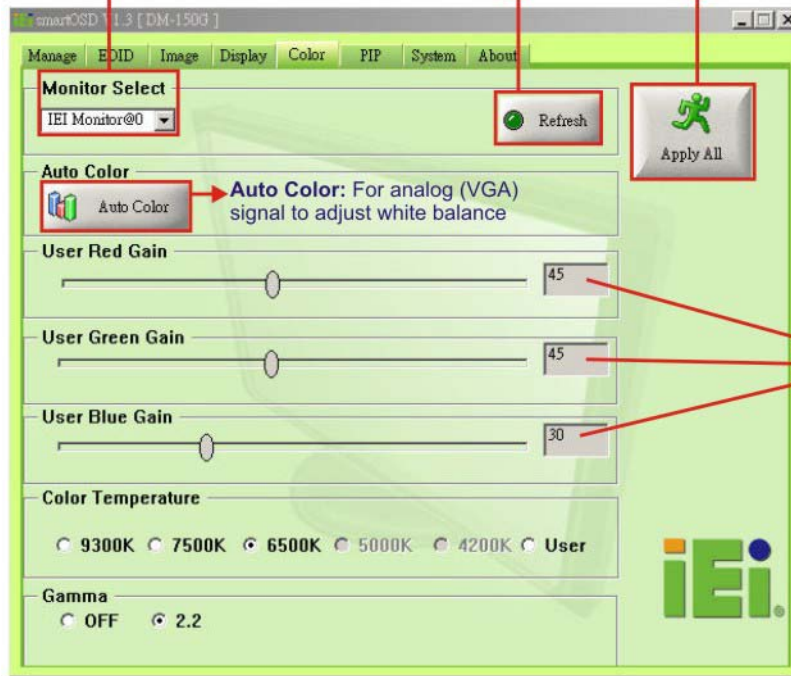

Range: 0~100 (Values can only be adjusted if user is selected for the Color Temperature)

C.4.6 PIP Page

**NOTE:**

The functions in the PIP page are only available in the MDM Series and AFOLUX Series monitors.



DM Series Monitor

C.4.7 System Page

Monitor Select: Selects the monitor unit for which the system parameters will be adjusted

Monitor Power Control: Press ALT+P buttons to boot the monitor again

Apply All: Delivering the system parameter settings to all the connecting monitors

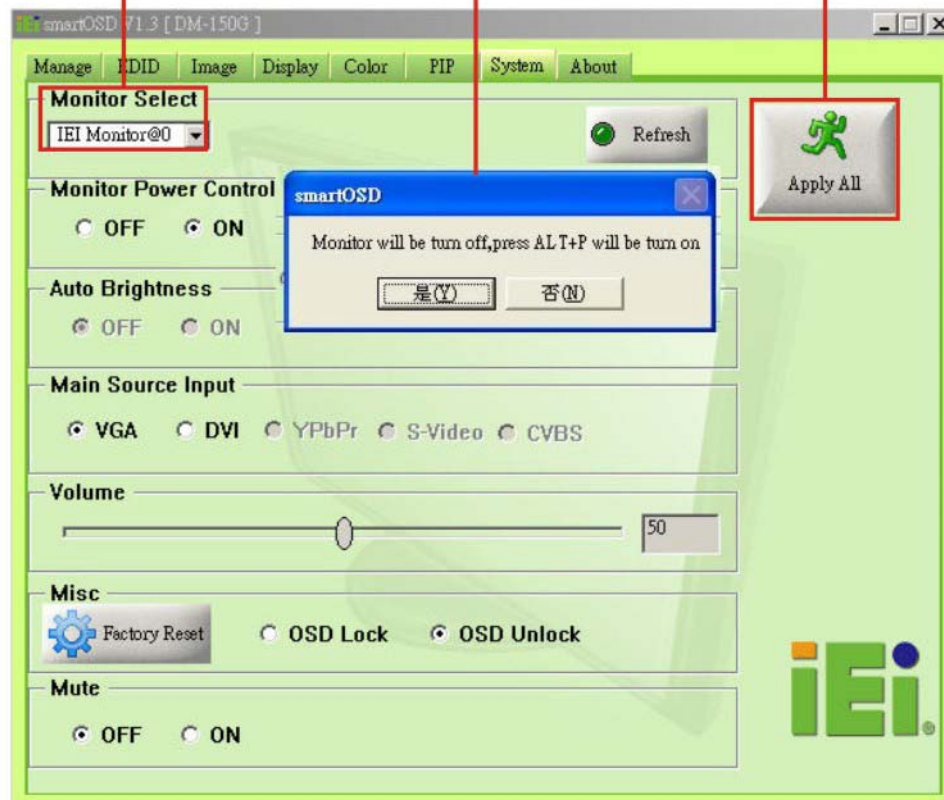

NOTE:

Some of the functions in the System Page are only available to some of the IEI LCD series as following:

- **Auto Brightness:** SRM, MDM and AFOLUX series only
- **Main Source Input:** MDM and AFOLUX series only
- **Volume:** AFOLUX series only
- **Mute:** AFOLUX series only

C.4.8 About Page



C.5 smartOSD FAQ

For troubleshooting, please see the steps below:

C.5.1 Windows 2000 Installation Failure

Installation fails under Windows 2000 and shows the following image:

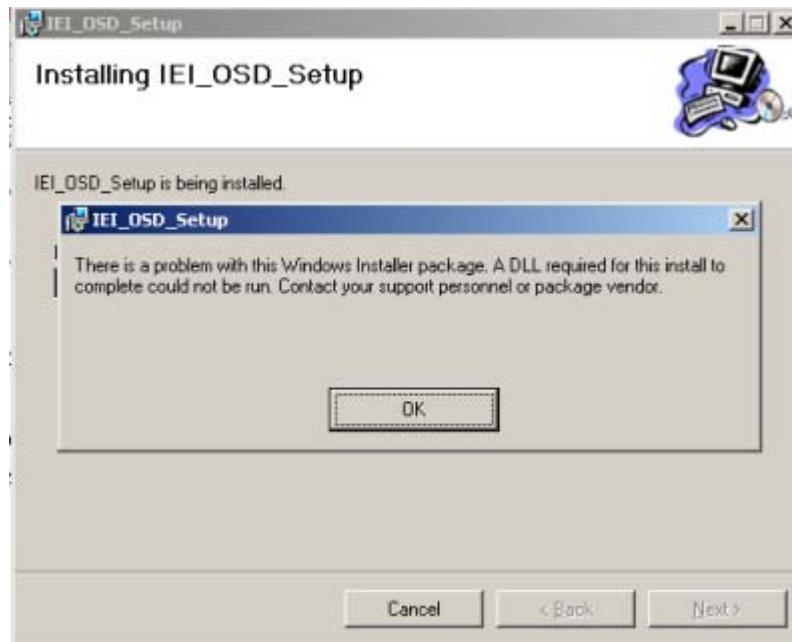

Figure C-9: DLL Missing

Solution: Download and install service pack Windows Installer 3.1

C.5.2 Vista Installation Failure

Installation fail under Vista while showing following image:



Figure C-10: Windows Vista Error

Solution: Install SmartOSD.exe as the administrator authority

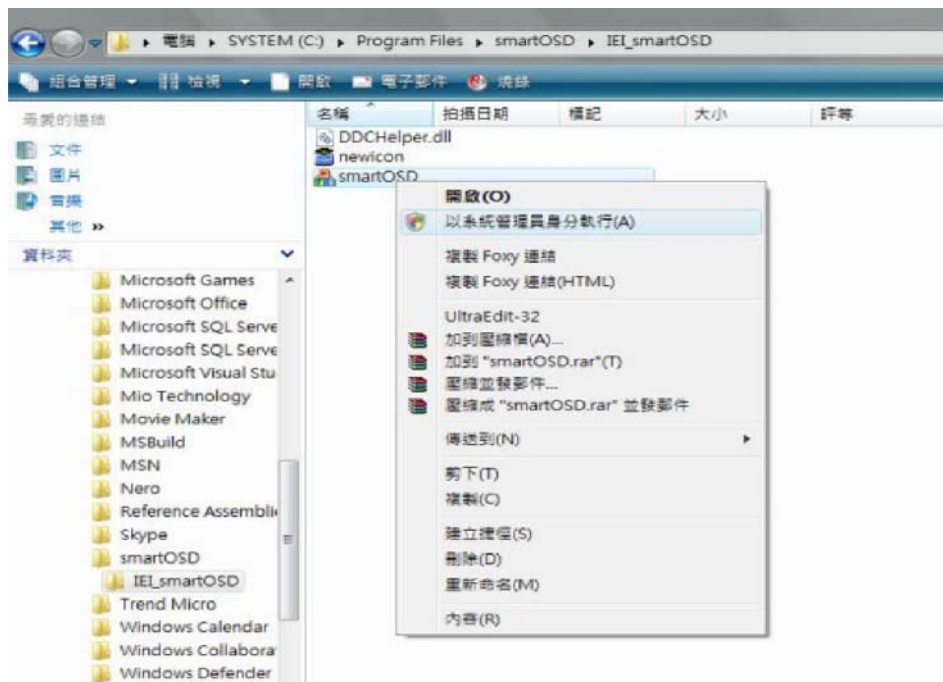

Figure C-11: Install as Administrator

C.5.3 Model Failure

The Model Fail error message shown below appears.



Figure C-12: Firmware Incompatibility

Solution: SmartOSD only supports firmware version 2.0 and following versions.

C.5.4 DDC Port Failure

The DDC port fail error message shown below appears.



Figure C-13: DCC Port Failure

Solutions:

- Check VGA or DVI cable
- Check an IEI monitor is being used
- Make sure the version is version 2.3 for the AFOLUX/MDM series and version 1.5 for the DM/ISDM/TDM/SRM/LCD-KIT series that have the SmartOSD functions
- Check if the OSD control status is busy. A busy signal may cause the signal message for a short time.