

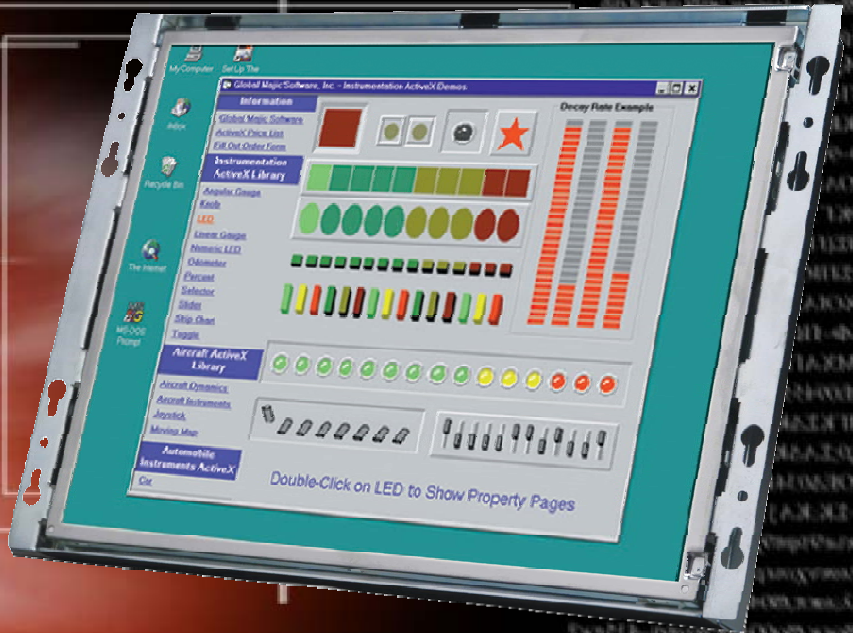

IEI Technology Corp.



MODEL: LCD-KIT Series

6.5" ~ 19" Open Frame LCD Monitor
OSD Controls, VGA, DVI-D, 12 V Input

User Manual

Rev. 2.02 – 18 February, 2011



Revision

Date	Version	Changes
18 February, 2011	2.02	Updated dimension drawings
15 December, 2010	2.01	Modified AV-6600 AD board information Modified Chapter 6 OSD Controls Modified Chapter 7 Software Driver
17 June, 2010	2.00	Updated for LCD-KIT-R20 series
30 September, 2009	1.13	Changed CN11 and CN12 pin definitions
20 July, 2009	1.12	Updated OSD chapter
31 May 2007	1.11	AV-5300 AD Board CN25 connector pin 3 voltage changed to +9V~+36V input
30 April 2007	1.10	Updated Figure 1-4 and Section 4.4 for AV-5300 AD Board V2.0
31 November 2006	1.00	Initial release

Copyright

COPYRIGHT NOTICE

The information in this document is subject to change without prior notice in order to improve reliability, design and function and does not represent a commitment on the part of the manufacturer.

In no event will the manufacturer be liable for direct, indirect, special, incidental, or consequential damages arising out of the use or inability to use the product or documentation, even if advised of the possibility of such damages.

This document contains proprietary information protected by copyright. All rights are reserved. No part of this manual may be reproduced by any mechanical, electronic, or other means in any form without prior written permission of the manufacturer.

TRADEMARKS

All registered trademarks and product names mentioned herein are used for identification purposes only and may be trademarks and/or registered trademarks of their respective owners.

Table of Contents

1 INTRODUCTION.....	1
1.1 LCD-KIT SERIES LCD MONITOR OVERVIEW	2
1.1.1 Standard Features	2
1.1.2 Model Variations	2
1.2 APPLICATIONS AND FEATURES	3
1.2.1 LCD-KIT Series LCD Monitor Applications	3
1.2.2 LCD-KIT Series LCD Monitor Features.....	3
1.3 EXTERNAL OVERVIEW	3
1.3.1 Front View	3
1.3.2 Rear View	4
1.3.3 Connectors	5
1.3.4 AD Board	6
1.4 SERIES SPECIFICATIONS.....	7
1.5 CERTIFICATIONS	7
2 MECHANICAL OVERVIEW	8
2.1 INTRODUCTION.....	9
2.2 REAR PANEL.....	9
2.2.1 Rear Panel Variants	9
2.2.2 Rear Panel Variant 1.....	9
2.2.3 Rear Panel Variant 2.....	10
2.3 CONNECTOR PANEL	11
2.3.1 Available Connectors	11
2.3.2 Variant 1 Connectors	11
2.3.3 Variant 2 Connectors	11
2.3.4 Variant 3 Connectors	11
2.3.5 Variant 4 Connectors	12
2.4 PHYSICAL DIMENSIONS	12
2.4.1 General Physical Dimensions.....	12
2.4.2 LCD-KIT190G Physical Dimensions.....	13
2.4.3 LCD-KIT170GS Physical Dimensions.....	14

LCD-KIT

2.4.4 LCD-KIT150G Physical Dimensions.....	15
2.4.5 LCD-KIT121G/GX Physical Dimensions	16
2.4.6 LCD-KIT104GH Physical Dimensions.....	17
2.4.7 LCD-KIT84GH Physical Dimensions.....	18
2.4.8 LCD-KIT65GH Physical Dimensions.....	19
2.5 MOUNTING OPTIONS	20
3 LCD SPECIFICATIONS	21
3.1 LCD SPECIFICATIONS.....	22
3.1.1 LCD Overview	22
3.1.2 LCD-KIT190G LCD Specifications	23
3.1.3 LCD-KIT170G LCD Specifications	24
3.1.4 LCD-KIT150G LCD Specifications	25
3.1.5 LCD-KIT121GX LCD Specifications.....	26
3.1.6 LCD-KIT121G LCD Specifications	27
3.1.7 LCD-KIT104GH LCD Specifications	28
3.1.8 LCD-KIT84GH LCD Specifications	29
3.1.9 LCD-KIT65GH LCD Specifications	30
3.2 POWER ADAPTERS.....	31
4 AD BOARDS	32
4.1 AD BOARD OVERVIEW.....	33
4.2 AV-9650 AD BOARD OVERVIEW	33
4.2.1 AV-9650 Peripheral Interface Connectors.....	34
4.2.2 AV-9650 Rear Panel Connectors	34
4.3 AV-6650 AD BOARD OVERVIEW	35
4.3.1 AV-6650 Peripheral Interface Connectors.....	36
4.3.2 AV-6650 Rear Panel Connectors	36
4.4 AV-6600 AD BOARD OVERVIEW	36
4.4.1 AV-6600 Peripheral Interface Connectors.....	37
4.4.2 AV-6600 Rear Panel Connectors	38
5 INSTALLATION	39
5.1 INSTALLATION PRECAUTIONS	40
5.2 UNPACKING.....	41
5.2.1 Packaging	41

5.2.2 Unpacking Procedure	41
5.2.3 Packing List	42
5.3 PRE-INSTALLATION PREPARATION	42
5.3.1 Tools	42
5.4 CONNECTORS	43
5.4.1 VGA Connector	43
5.4.2 DVI-D Connector	43
5.4.3 12V Power Connector	44
5.5 MOUNTING THE LCD-KIT SERIES LCD MONITOR	44
6 OSD CONTROLS	45
6.1 USER MODE OSD STRUCTURE	46
6.1.1 OSD Buttons	46
6.1.2 OSD Menu Structure	47
6.2 USING THE OSD	48
6.2.1 Main Display Features	48
6.2.2 Color	49
6.2.3 OSD Configurations	50
7 SOFTWARE DRIVER	51
7.1 INTRODUCTION	52
7.2 RS-232 OR USB TOUCH SCREEN	52
7.3 TOUCH PANEL DRIVER INSTALLATION	53
7.4 CHANGE THE TOUCH SCREEN INTERFACE	56
7.5 CALIBRATING THE TOUCH SCREEN	56
A CERTIFICATIONS	59
A.1 RoHS COMPLIANT	60
B SAFETY PRECAUTIONS	61
B.1 SAFETY PRECAUTIONS	62
B.1.1 General Safety Precautions	62
B.1.2 Anti-static Precautions	63
B.2 MAINTENANCE AND CLEANING PRECAUTIONS	63
B.2.1 Maintenance and Cleaning	63
B.2.2 Cleaning Tools	64

C SMARTOSD	65
C.1 IEI SMARTOSD QUICK INSTALLATION GUIDE	66
C.2 PRE-INSTALLATION NOTICE	66
C.3 SMARTOSD INSTALL	67
C.4 SOFTWARE ILLUSTRATION	71
C.4.1 <i>Manage Page</i>	73
C.4.2 <i>EDID Page</i>	74
C.4.3 <i>Image Page</i>	75
C.4.4 <i>Display Page (for analog signal)</i>	76
C.4.5 <i>Color Page</i>	77
C.4.6 <i>PIP Page</i>	78
C.4.7 <i>System Page</i>	79
C.4.8 <i>About Page</i>	81
C.5 SMARTOSD FAQ.....	82
C.5.1 <i>Windows 2000 Installation Failure</i>	82
C.5.2 <i>Vista Installation Failure</i>	83
C.5.3 <i>Model Failure</i>	84
C.5.4 <i>DCC Port Failure</i>	84

List of Figures

Figure 1-1: Typical LCD-KIT Front View	4
Figure 1-2: Typical LCD-KIT Rear View	5
Figure 1-3: Typical LCD-KIT Connectors	5
Figure 1-4: AV-6600 AD Board	6
Figure 2-1: Rear Panel Variant 1	10
Figure 2-2: Rear Panel Variant 2	10
Figure 2-3: LCD-KIT190G Physical Dimensions (millimeters)	13
Figure 2-4: LCD-KIT170G Physical Dimensions (millimeters)	14
Figure 2-5: LCD-KIT150G Physical Dimensions (millimeters)	15
Figure 2-6: LCD-KIT121G/GX Physical Dimensions (millimeters)	16
Figure 2-7: LCD-KIT104GH Physical Dimensions (millimeters).....	17
Figure 2-8: LCD-KIT84GH Physical Dimensions (millimeters).....	18
Figure 2-9: LCD-KIT65GH Physical Dimensions (millimeters).....	19
Figure 4-1: AV-9650 AD Board Overview	33
Figure 4-2: AV-6650 AD Board Overview	35
Figure 4-3: AV-6600 AD Board Overview	37
Figure 5-1: VGA Connector	43
Figure 5-2: DVI-D Connector	44
Figure 5-3: 12V Power Connector	44
Figure 6-1: OSD Control Buttons (Except 6.5")	46
Figure 6-2: LCD-KIT65 OSD Control Buttons	47
Figure 6-3: Main Display Features	48
Figure 6-4: Color Options	49
Figure 6-5: OSD Configurations Menu	50
Figure 7-1: Setup Icon.....	53
Figure 7-2: Welcome Screen	54
Figure 7-3: License Agreement	54
Figure 7-4: Initiate Install	55
Figure 7-5: Installation Starts	55
Figure 7-6: Finish Installation.....	56

LCD-KIT

Figure 7-7: PenMount Monitor Icon	57
Figure 7-8: PenMount Monitor Popup Menu	57
Figure 7-9: Configuration Screen.....	57
Figure 7-10: Calibration Initiation Screen	58
Figure 7-11: Calibration Screen	58
Figure C-1: smartOSD Installer	67
Figure C-2: smartOSD Welcome Screen	68
Figure C-3: smartOSD Folder Select Screen	68
Figure C-4: smartOSD Confirm Installation	69
Figure C-5: smartOSD Installation Progress	69
Figure C-6: smartOSD Installation Complete	70
Figure C-7: smartOSD Desktop Icon	70
Figure C-8: Manage Page.....	73
Figure C-9: EDID Page	74
Figure C-10: Image Page.....	75
Figure C-11: Display Page	76
Figure C-12: Color Page.....	77
Figure C-13: PIP Page	78
Figure C-14: System Page	79
Figure C-15: About Page.....	81
Figure C-16: DLL Missing	82
Figure C-17: Windows Vista Error	83
Figure C-18: Install as Administrator.....	83
Figure C-19: Firmware Incompatibility	84
Figure C-20: DCC Port Failure.....	84

List of Tables

Table 1-1: LCD-KIT Series Specifications	7
Table 2-1: Rear Panel Variants	9
Table 2-2: General Physical Dimensions	12
Table 2-3: Mounting Holes	20
Table 3-1: LCD-KIT190G LCD Specifications.....	23
Table 3-2: LCD-KIT170G LCD Specifications.....	24
Table 3-3: LCD-KIT150G LCD Specifications.....	25
Table 3-4: LCD-KIT121GX LCD Specifications	26
Table 3-5: LCD-KIT121G LCD Specifications.....	27
Table 3-6: LCD-KIT104GH LCD Specifications	28
Table 3-7: LCD-KIT84GH LCD Specifications	29
Table 3-8: LCD-KIT65GH LCD Specifications	30
Table 3-9: Power Adapter Specifications	31
Table 4-1: AV-9650 Peripheral Interface Connectors.....	34
Table 4-2: AV-9650 Rear Panel Connectors.....	34
Table 4-3: AV-6650 Peripheral Interface Connectors.....	36
Table 4-4: AV-6650 Rear Panel Connectors.....	36
Table 4-5: AV-6600 Peripheral Interface Connectors.....	38
Table 4-6: AV-6600 Rear Panel Connectors.....	38
Table 5-1: Rear Panel Connectors	43
Table 5-2: VGA Connector Pinouts.....	43
Table 5-3: DVI-D Connector Pinouts.....	44
Table 6-1: OSD Menus.....	48
Table C-1: SmartOSD Menu Structure.....	72

Chapter

1

Introduction

1.1 LCD-KIT Series LCD Monitor Overview

The LCD-KIT series LCD monitor is the latest member of IEI's line of sophisticated LCD designs, and it has been improved to be RoHS compliant. It is designed to fit industrial automation, or any other applications that require minimum installation space and flexible configuration. Flexible analog or digital interfaces are provided for ease of connection with a management computer. If remote/non-attentive control is preferred, RS-232 or USB interfaces can be used with customized adapter cables.

1.1.1 Standard Features

All the base models listed in **Section 1.2.1** have the following standard features

- LCD monitor
- OSD controls
- VGA
- Robust metal chassis
- RoHS compliant

1.1.2 Model Variations

The LCD-KIT series offers the following model variations.

- LCD-KIT65GH: 6.5" TFT LCD
- LCD-KIT84GH: 8.4" TFT LCD
- LCD-KIT84GHM: 8.4" TFT LCD, 9~36 V DC power input
- LCD-KIT104GH: 10.4" TFT LCD
- LCD-KIT104GHM: 10.4" TFT LCD, 9~36 V DC power input
- LCD-KIT121G: 12.1" TFT LCD
- LCD-KIT121GM: 12.1" TFT LCD, 9~36 V DC power input
- LCD-KIT121GX: 12.1" TFT LCD
- LCD-KIT121GXM: 12.1" TFT LCD, 9~36 V DC power input
- LCD-KIT150G: 15" TFT LCD
- LCD-KIT150GM: 15" TFT LCD, 9~36 V DC power input
- LCD-KIT170GM: 17" TFT LCD, 9~36 V DC power input
- LCD-KIT170GS: 17" TFT LCD
- LCD-KIT190G: 19" TFT LCD

LCD-KIT

- LCD-KIT190GM: 19" TFT LCD, 9~36 V DC power input

1.2 Applications and Features

1.2.1 LCD-KIT Series LCD Monitor Applications

IEI's series of LCD monitors are designed for system manufacturers, integrators, or value-added resellers that want to provide all the performance, quality and reliability of an LCD display solution at a cost effective price. IEI's LCD kits offer additional components such as cables, an inverter and power supply with controller interfaces that include VGA and DVI.

1.2.2 LCD-KIT Series LCD Monitor Features

Some of the features of the LCD-KIT series LCD monitor include:

- Analog VGA interface supports most general system boards
- Over 300 cd/m² high brightness and 50,000 hrs MTFB long lifetime panel
- Advanced thermal and air-flow design
- Supports panel mounting
- 12 V DC power input via adapter
- M models have 9~36 V DC power connector
- Long product life support
- RoHS compliant

1.3 External Overview

The following sections describe the physical layout of the LCD-KIT series LCD monitors.

1.3.1 Front View

The front of the LCD-KIT series LCD monitor is a flat panel TFT LCD screen attached to a metal chassis. Figure 1-1 shows a typical LCD-KIT front view.



Figure 1-1: Typical LCD-KIT Front View

1.3.2 Rear View

The rear of the LCD-KIT series LCD monitor is a metal chassis. An on screen display (OSD) control button panel, if present, is located vertically on the left side of the chassis with the following control buttons:

- LCD On/Off
- Auto
- Left
- Right
- Menu

The OSD panel also has one power LED.

Figure 1-2 shows a typical LCD-KIT rear panel.

LCD-KIT



Figure 1-2: Typical LCD-KIT Rear View

1.3.3 Connectors

Each LCD-KIT series LCD monitor has a number of interface connectors on either the top or right panel of the chassis (when viewing the rear panel). Figure 1-3 shows a typical LCD-KIT connector panel. Each model may include or exclude additional connectors. Refer to **Section 2.3** for listings of LCD-KITs and their connectors. All connectors are fully described in **Section 5.4**.

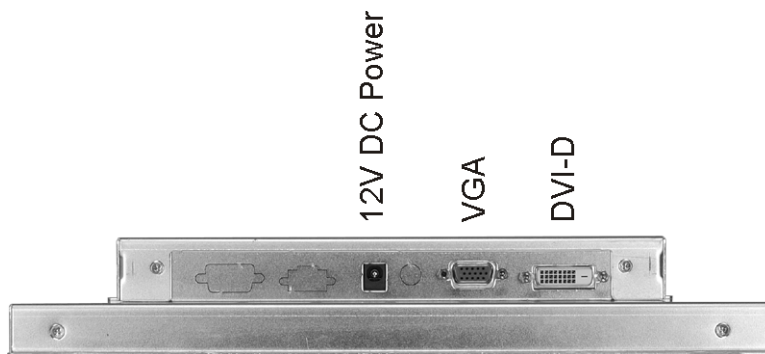

Figure 1-3: Typical LCD-KIT Connectors

1.3.4 AD Board

The LCD-KIT series LCD monitor AD boards provide a wide variety of control interfaces, receiving and managing signals from a CPU card through cabling. Figure 1-4 shows the AV-6600 AD board as a sample of a typical AD board for the LCD-KIT series LCD monitor. Refer to **Chapter 4** for a complete description of AD boards and their connectors.

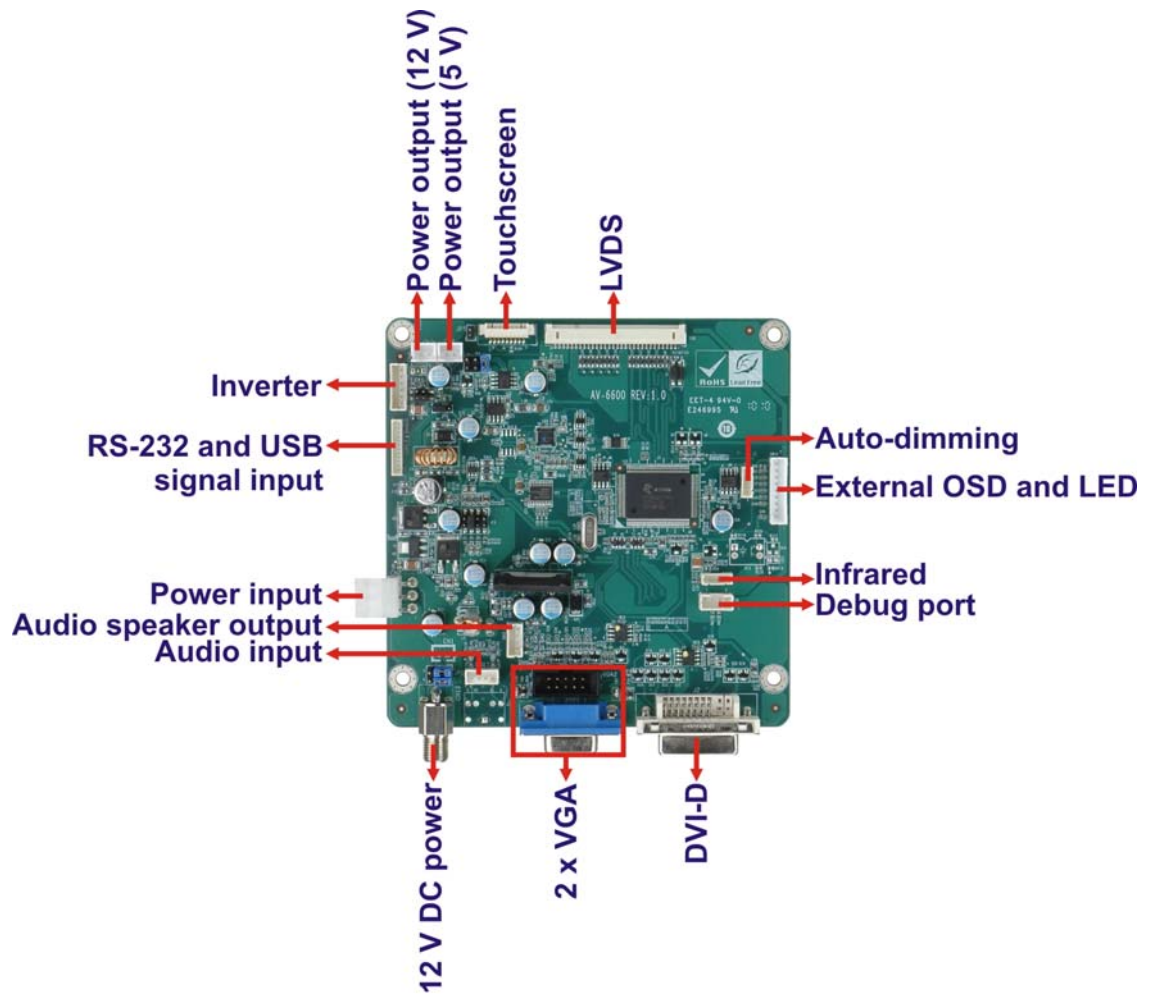

Figure 1-4: AV-6600 AD Board

LCD-KIT

1.4 Series Specifications

The table below shows the LCD-KIT Series specifications.

LCD-KIT	65GH	84GH	104GH	121G	121GX	150G	170G	190G
LCD Type	6.5" TFT	8.4" TFT	10.4" TFT	12.1" TFT	12.1" TFT	15" TFT	17" TFT	19" TFT
Input Interface	VGA			VGA + DVI-D				
Max. Resolution	640x480	800x600			1024x768			1280x1024
Backlight MTBF	50,000 Hrs							
Contrast	600:1		700:1				800:1	1000:1
LCD Color	262K					16.2M		
Brightness (cd/m ²)	700	450	400	450	500	350	300	
AD Board	AV-9650	AV-6650		AV-6600				
Power Adapter	36W 63000-FSP036RAB610-R			50W TBD				
Chassis	Heavy-duty steel							
View Angle (H / V)	160/140				160/160	140/125	170/160	
OSD function	Yes							
Mounting	Panel							
Dimensions (WxHxD) (mm)	203 x 121 x 34	234 x 147 x 35.3	242.2 x 209 x 33.6	294 x 240.7 x 42	294 x 240.7 x 42	364.1 x 262.5 x 41.9	390.4 x 300 x 46.9	427.9 x 327.4 x 48.4
Operating Temperature	-10°C ~ 50°C							

Table 1-1: LCD-KIT Series Specifications

1.5 Certifications

All LCD-KIT series LCD monitor models comply with the following international standards:

- RoHS

For a more detailed description of these standards, please refer to **Appendix A**.

Chapter

2

Mechanical Overview

2.1 Introduction

This chapter describes the general mechanical overview of the LCD-KIT series LCD monitors including rear panel variations, available interfaces and overall dimensions.

2.2 Rear Panel

The rear panel of the LCD-KIT series LCD monitor is comprised of a metal chassis with an OSD control panel.

2.2.1 Rear Panel Variants

Table 2-1 shows the rear panel variants for the LCD-KIT series LCD monitor.

Model	OSD Control Panel Location	Variant Number
LCD-KIT190G LCD-KIT170G LCD-KIT150G LCD-KIT121GX LCD-KIT121G LCD-KIT104GH LCD-KIT84GH	Vertically along the left side of the rear panel.	1
LCD-KIT65GH	In line along the bottom of the rear panel.	2

Table 2-1: Rear Panel Variants

2.2.2 Rear Panel Variant 1

The following models of the LCD-KIT series LCD monitor have an OSD control panel located vertically along the left side of the rear panel:

- LCD-KIT190G
- LCD-KIT170G
- LCD-KIT150G
- LCD-KIT121GX
- LCD-KIT121G

- LCD-KIT104GH
- LCD-KIT84GH

Figure 2-1 shows the location of the rear panel variant 1 OSD controls.

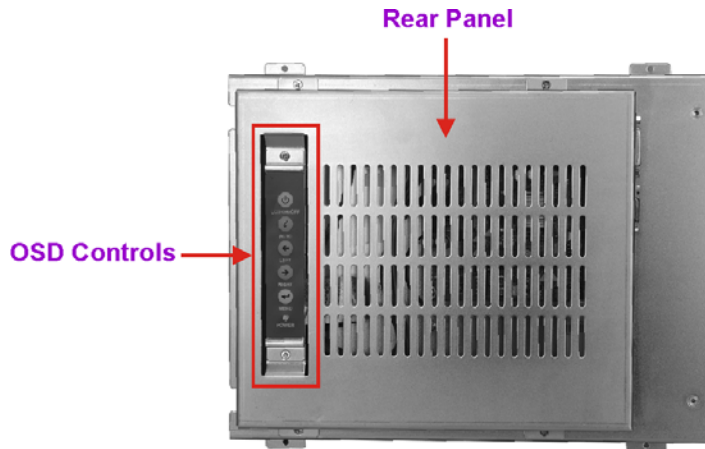

Figure 2-1: Rear Panel Variant 1

2.2.3 Rear Panel Variant 2

The following model of the LCD-KIT series LCD monitor has OSD control buttons located on the bottom of the rear panel:

- LCD-KIT65GH

Figure 2-2 shows the location of the rear panel variant 2 OSD controls.

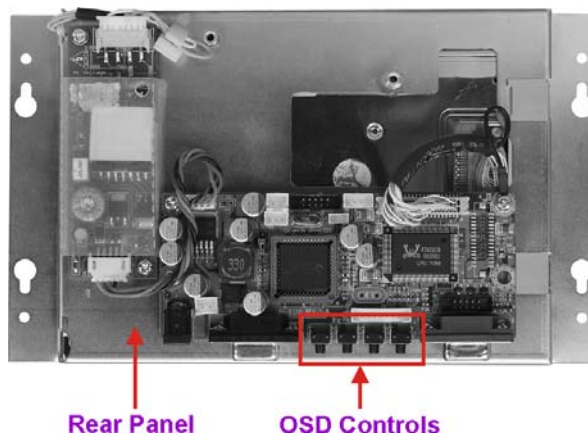

Figure 2-2: Rear Panel Variant 2

LCD-KIT

2.3 Connector Panel

All external peripheral interface connectors are located on the rear panel of the LCD-KIT series LCD monitor. The following sections describe the rear panel variants and their associated connectors.

2.3.1 Available Connectors

There are a number of rear panel peripheral device connectors available for the LCD-KIT series LCD monitor.

- VGA connector
- DVI-D connector
- 12 V DC power connector
- 9~36 V DC power connector

2.3.2 Variant 1 Connectors

The following is a list of the bottom panel peripheral device connectors used on the LCD-KIT65GH, LCD-KIT84GH and LCD-KIT104GH series LCD monitor.

- VGA connector
- 12 V DC power connector

2.3.3 Variant 2 Connectors

The following is a list of the bottom panel peripheral device connectors used on the LCD-KIT121GX, LCD-KIT150G, LCD-KIT170GS and LCD-KIT190G series LCD monitor.

- VGA connector
- DVI-D connector
- 12 V DC power connector

2.3.4 Variant 3 Connectors

The following is a list of the bottom panel peripheral device connectors used on the LCD-KIT84GHM and LCD-KIT104GHM series LCD monitor.

- VGA connector

- 9~36 V DC power connector

2.3.5 Variant 4 Connectors

The following is a list of the bottom panel peripheral device connectors used on the LCD-KIT121GXM, LCD-KIT150GM, LCD-KIT170GM and LCD-KIT190GM series LCD monitor.

- VGA connector
- DVI-D connector
- 9~36 V DC power connector

2.4 Physical Dimensions

The following sections describe the physical dimensions for each model of the LCD-KIT series LCD monitor.

2.4.1 General Physical Dimensions

General physical dimensions for the LCD-KIT series LCD monitors are shown in Table 2-2.

Model	Width (mm)	Height (mm)	Depth (mm)
LCD-KIT190G	427.9	327.0	48.7
LCD-KIT170GS	390.4	299.6	46.3
LCD-KIT150G	364.1	262.1	41.3
LCD-KIT121G/GX	294.0	240.7	41.3
LCD-KIT104GH	244.5	209.0	43.4
LCD-KIT84GH	234.0	147.0	44.0
LCD-KIT65GH	203.4	121.0	34.0

Table 2-2: General Physical Dimensions

LCD-KIT

2.4.2 LCD-KIT190G Physical Dimensions

The physical dimensions of the LCD-KIT190G are shown in Figure 2-3.

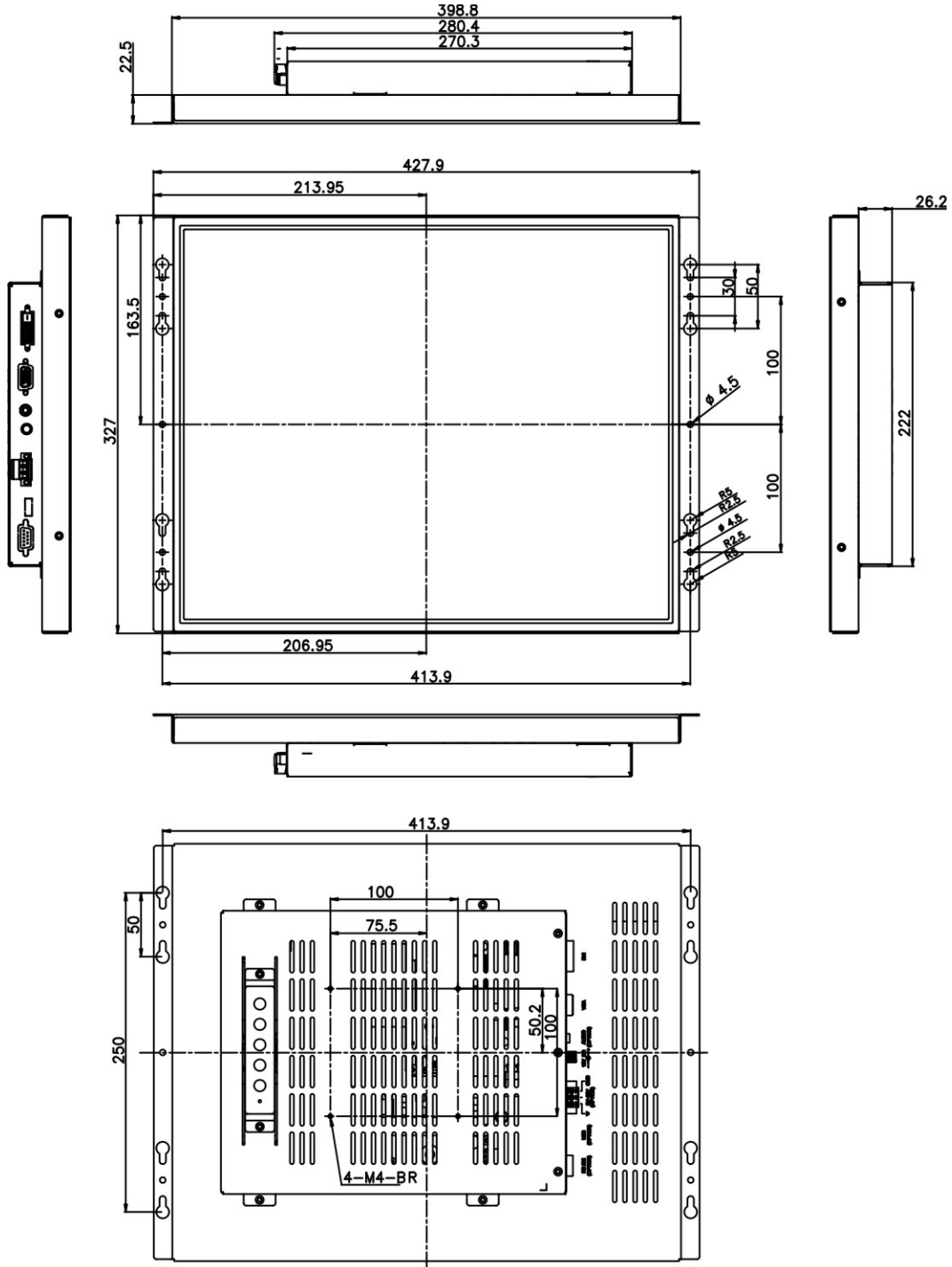

Figure 2-3: LCD-KIT190G Physical Dimensions (millimeters)

2.4.3 LCD-KIT170GS Physical Dimensions

The physical dimensions of the LCD-KIT170GS are shown in Figure 2-4.

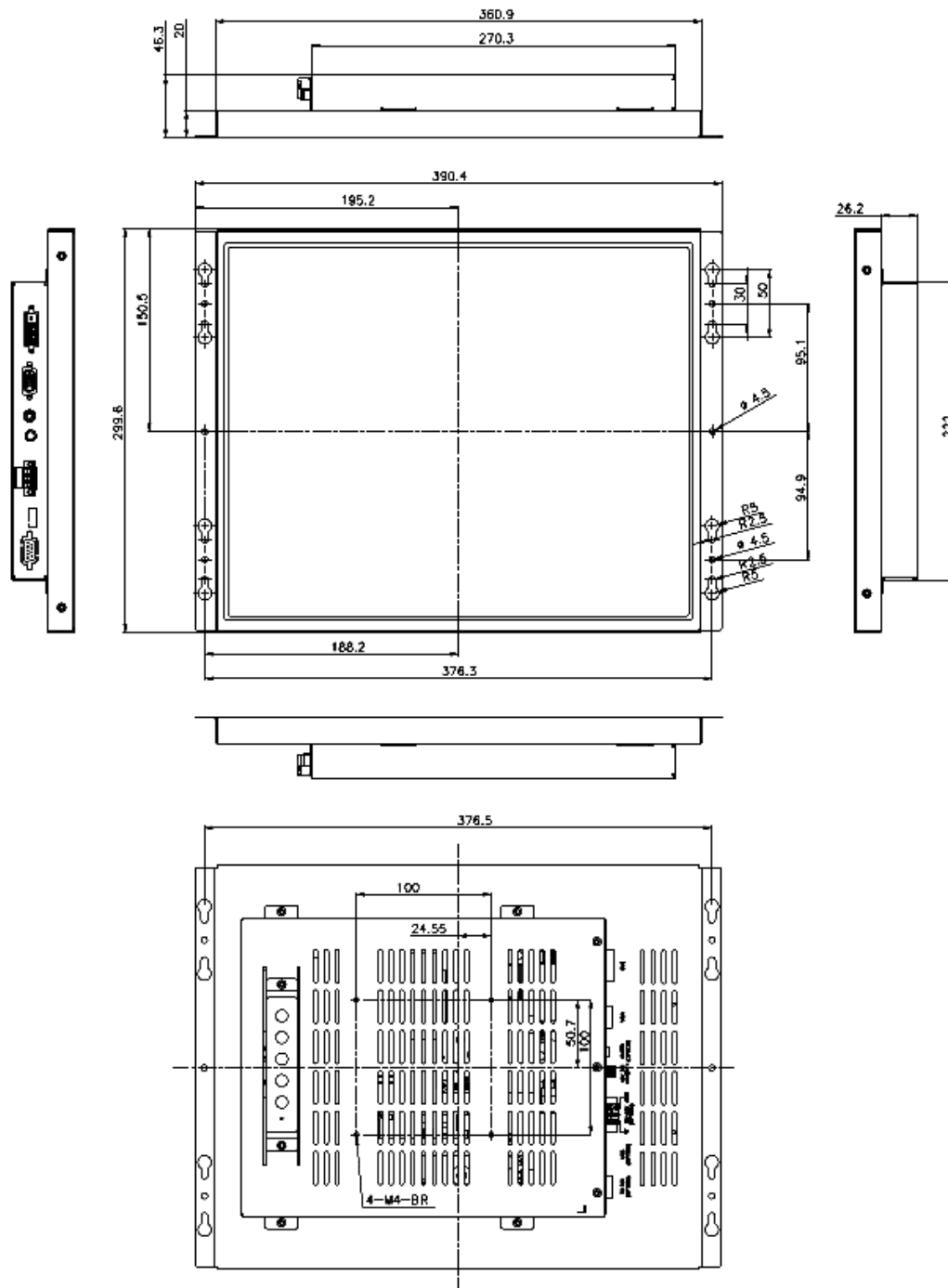

Figure 2-4: LCD-KIT170G Physical Dimensions (millimeters)

LCD-KIT

2.4.4 LCD-KIT150G Physical Dimensions

The physical dimensions of the LCD-KIT150G are shown in Figure 2-5.

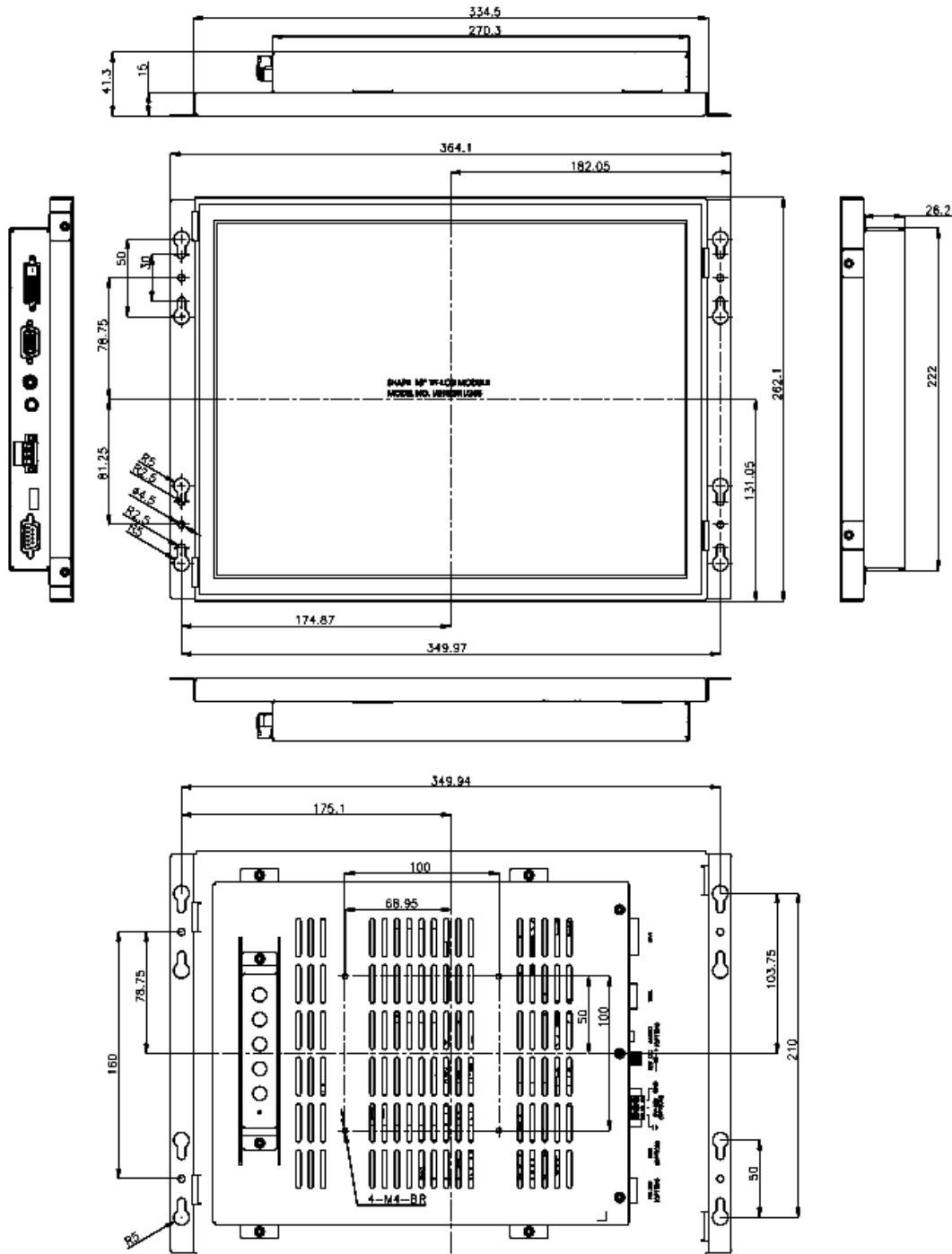

Figure 2-5: LCD-KIT150G Physical Dimensions (millimeters)

2.4.5 LCD-KIT121G/GX Physical Dimensions

The physical dimensions of the LCD-KIT121G/GX are shown in Figure 2-6.

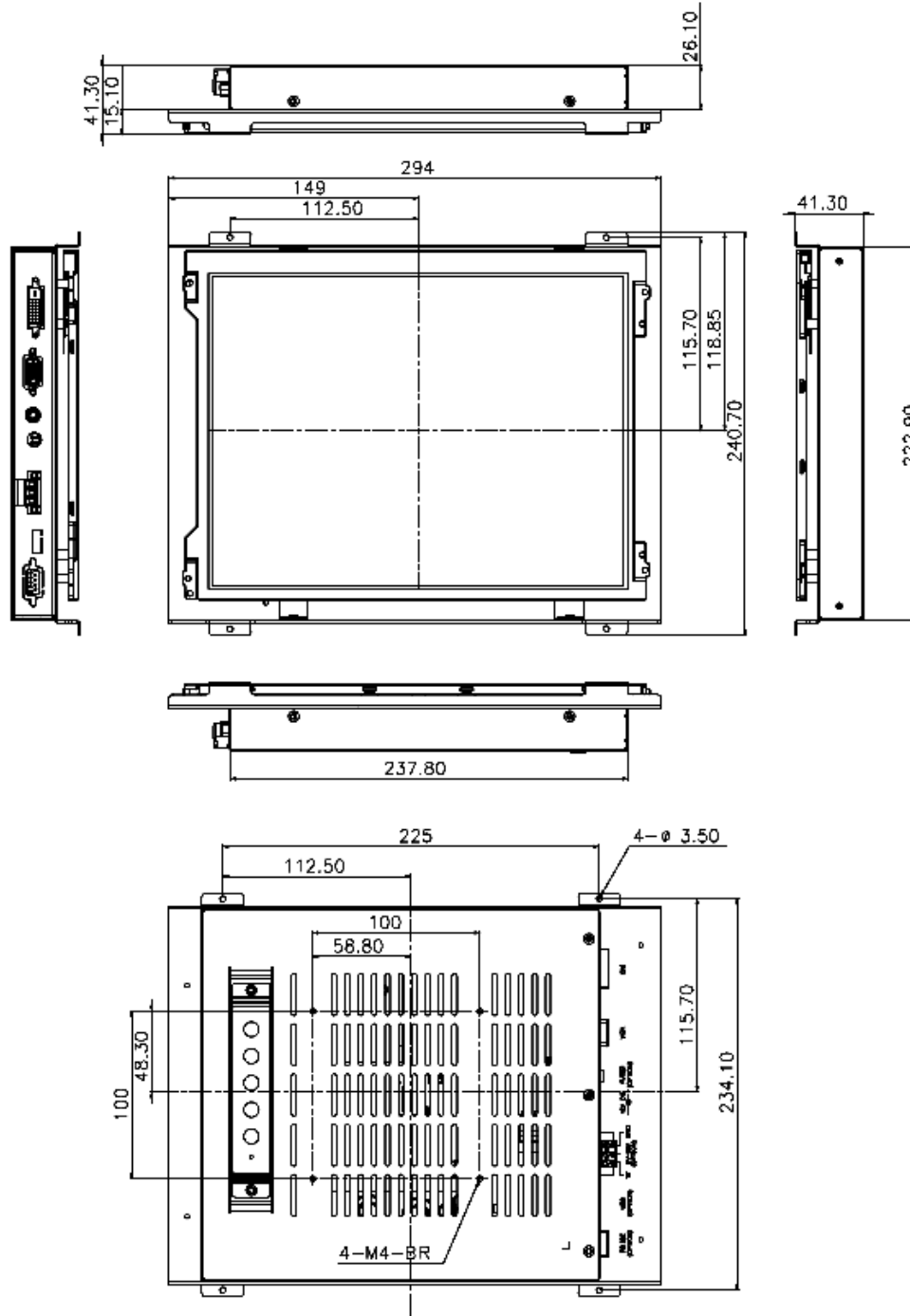

Figure 2-6: LCD-KIT121G/GX Physical Dimensions (millimeters)

LCD-KIT

2.4.6 LCD-KIT104GH Physical Dimensions

The physical dimensions of the LCD-KIT104GH are shown in Figure 2-7.

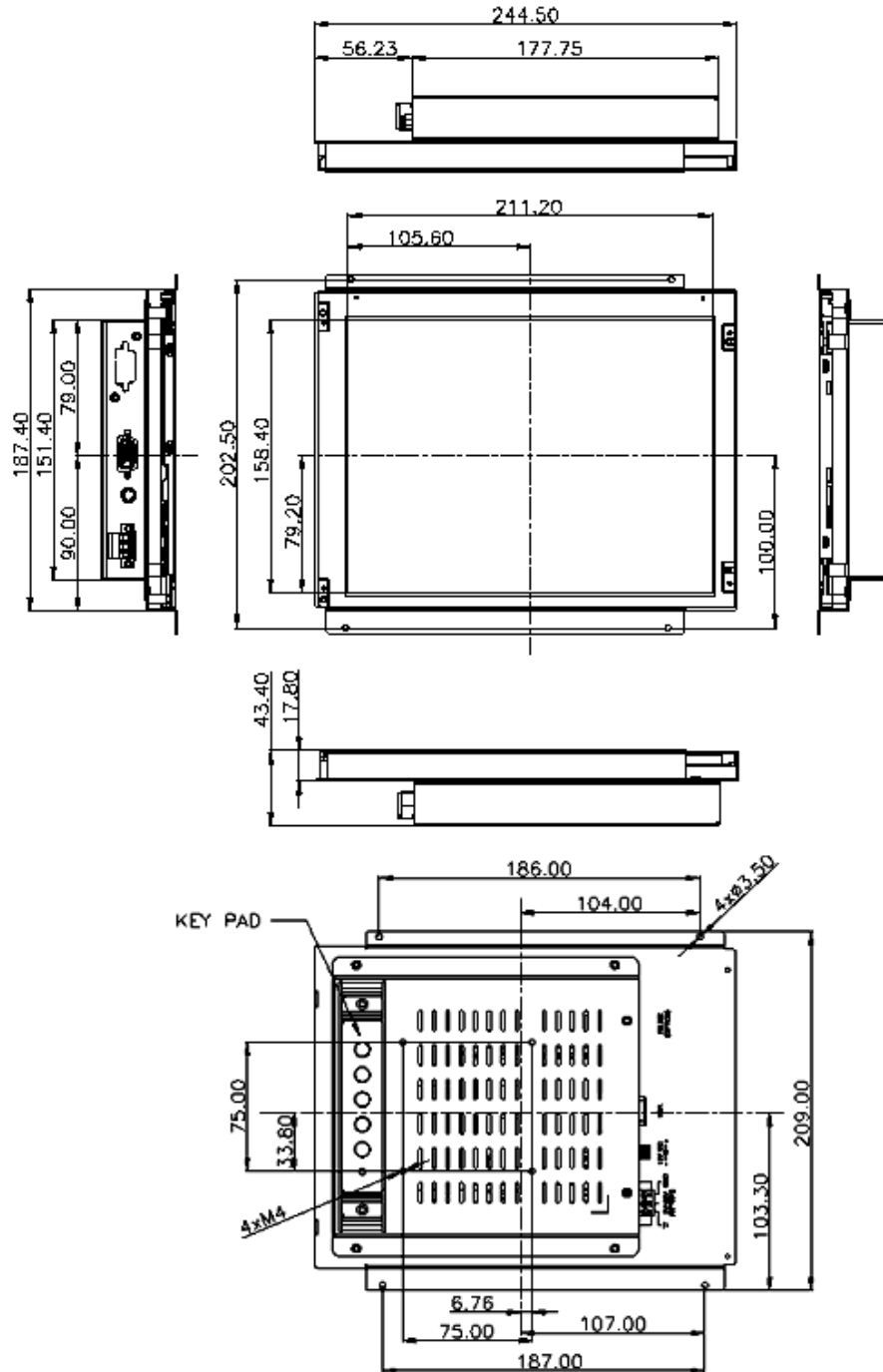

Figure 2-7: LCD-KIT104GH Physical Dimensions (millimeters)

2.4.7 LCD-KIT84GH Physical Dimensions

The physical dimensions of the LCD-KIT84GH are shown in Figure 2-8.

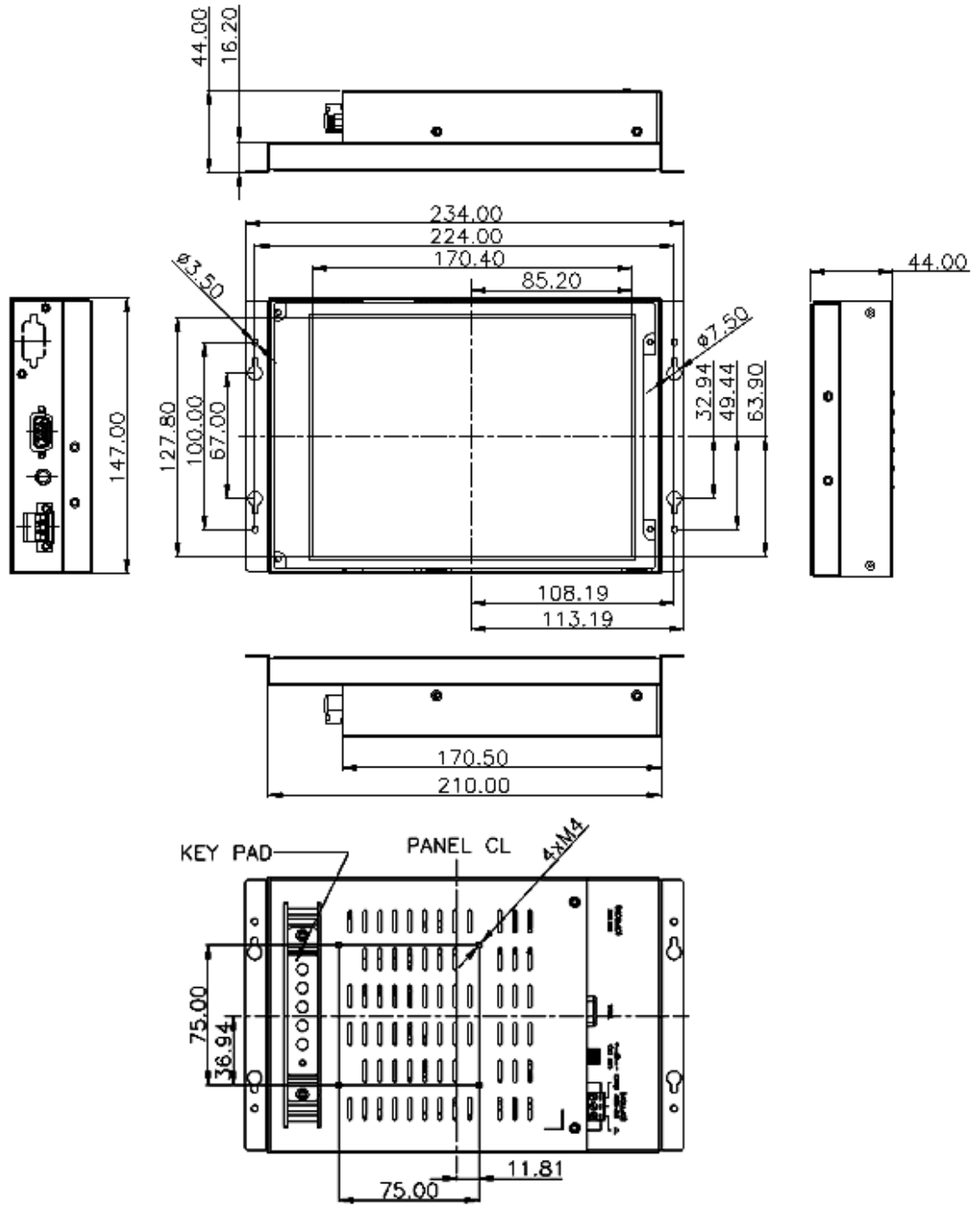

Figure 2-8: LCD-KIT84GH Physical Dimensions (millimeters)

LCD-KIT

2.4.8 LCD-KIT65GH Physical Dimensions

The physical dimensions of the LCD-KIT65GH are shown in Figure 2-9.

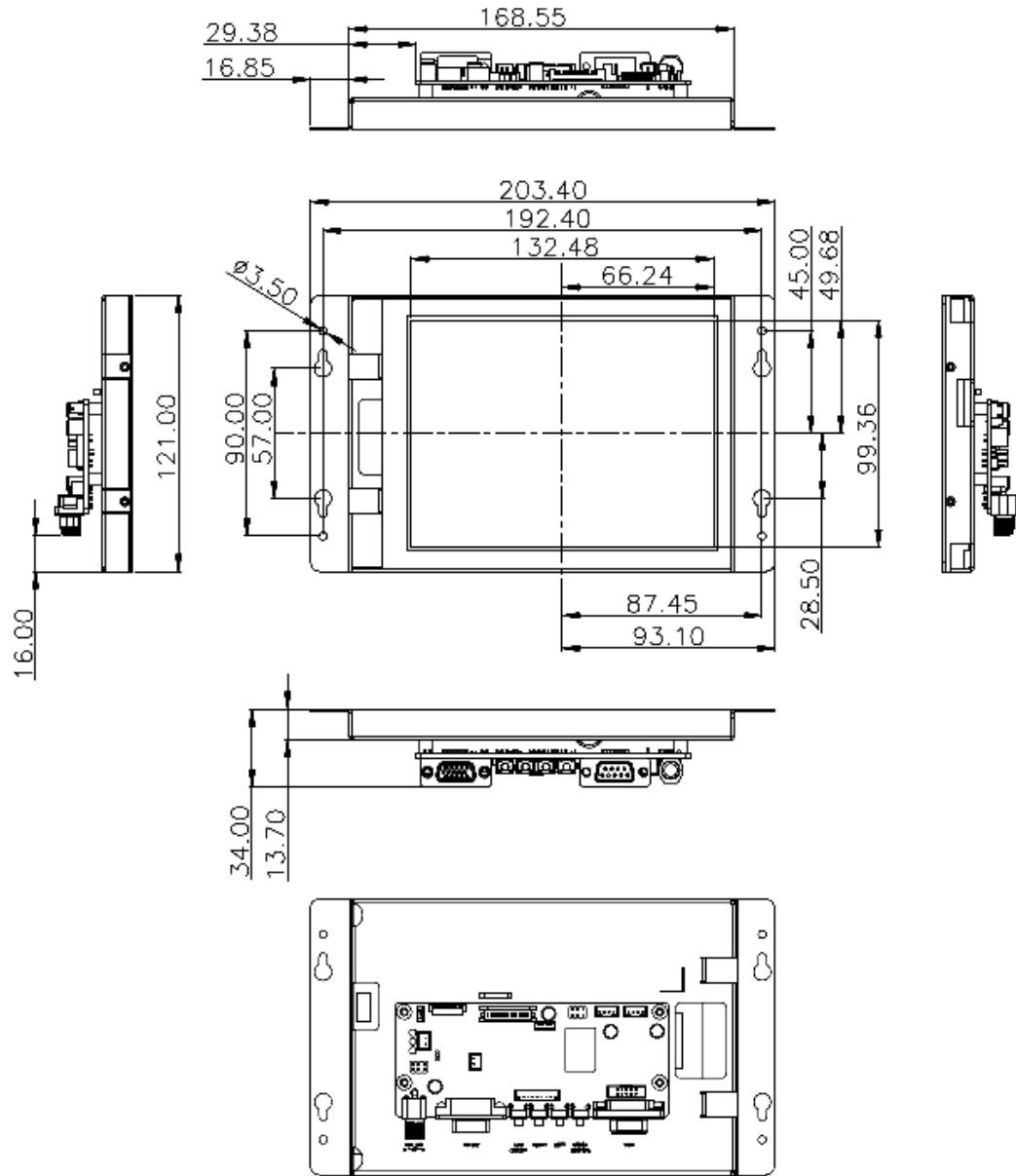

Figure 2-9: LCD-KIT65GH Physical Dimensions (millimeters)

2.5 Mounting Options

Each LCD-KIT series LCD monitor has mounting holes located on the mounting bracket. Table 2-3 details the number of mounting holes for each model of the LCD-KIT series LCD monitor. Refer to **Section 2.4** for more information.

Model	No. of Round Holes - Size	No. of Slotted Holes
LCD-KIT190G	6 – 4 mm diameter	8
LCD-KIT170G	6 – 4.5 mm diameter	8
LCD-KIT150G	6 – 4.5 mm diameter	8
LCD-KIT121G/GX	4 – 3.5 mm diameter	-
LCD-KIT104GH	4 – 3.5 mm diameter	-
LCD-KIT84GH	4 – 3.5 mm diameter	4
LCD-KIT65GH	4 – 3.5 mm diameter	4

Table 2-3: Mounting Holes

Chapter

3

LCD Specifications

3.1 LCD Specifications

3.1.1 LCD Overview

The LCD-KIT series industrial LCD monitors use the following LCD panels.

- **LCD-KIT190G:** HANNSTAR/HSD190MEN3-A
- **LCD-KIT170G:** AUO G170EG01 V0
- **LCD-KIT150G:** AUO G150XG01 V1
- **LCD-KIT121GX:** AUO G121XN01 V0
- **LCD-KIT121G:** AUO G121SN01 V4
- **LCD-KIT104GH:** AUO/G104SN02 V2
- **LCD-KIT084GH:** AUO/G084SN05 V8
- **LCD-KIT65GH:** AUO/G065VN01 V2

Detailed specifications for the LCD screens are listed in the following sections.

3.1.2 LCD-KIT190G LCD Specifications

The table below lists the LCD-KIT190G LCD specifications.

Model	LCD-KIT190G
Size	19"
MFR/Model	HANNSTAR/HSD190MEN3 -A
Resolution	SXGA (1280 x 1024)
Active Area (mm)	376.32 x 301.06
Pixel Pitch (mm)	0.294
Mode	TN
Number of Colors	16.7M
Color Saturation (NTSC%)	72
View Angle (H/V)	170 / 160
Brightness (cd/m2)	300
Contrast Ratio	1000:1
Response Time (ms) (at 25C)	5
Interface	2ch LVDS
Supply Voltage (V)	5
Backlight	4 CCFL

Table 3-1: LCD-KIT190G LCD Specifications

3.1.3 LCD-KIT170G LCD Specifications

The table below lists the LCD-KIT170G LCD specifications.

Model	LCD-KIT170G
Size	17"
MFR/Model	AUO/G170EG01 V0
Resolution	SXGA (1280 x 1024)
Active Area (mm)	337.9 x 270.3
Pixel Pitch (mm)	0.264
Mode	TN
Number of Colors	16.7M
Color Saturation (NTSC%)	72
View Angle (H/V)	170/160
Brightness (cd/m²)	350
Contrast Ratio	800:1
Response Time (ms) (at 25C)	8
Power Consumption (W)	25.2
Interface	2ch LVDS
Supply Voltage (V)	5
Backlight	4 CCFL
Lamp Life (hrs)	50,000

Table 3-2: LCD-KIT170G LCD Specifications

3.1.4 LCD-KIT150G LCD Specifications

The table below lists the LCD-KIT150G LCD specifications.

Model	LCD-KIT150G
Size	15"
MFR/Model	AUO/G150XG01 V1
Resolution	XGA (1024 x 768)
Active Area (mm)	304.1 x 228.1
Pixel Pitch (mm)	0.297
Mode	TN
Number of Colors	16.2M
Color Saturation (NTSC%)	65
View Angle (H/V)	140/120
Brightness (cd/m²)	350
Contrast Ratio	700:1
Response Time (ms) (at 25C)	8
Power Consumption (W)	8.9
Interface	1ch LVDS
Supply Voltage (V)	3.3
Backlight	2 CCFL
Lamp Life (hrs)	50000

Table 3-3: LCD-KIT150G LCD Specifications

3.1.5 LCD-KIT121GX LCD Specifications

The table below lists the LCD-KIT121GX LCD specifications.

Model	LCD-KIT121GX
Size	12.1"
MFR/Model	AUO/G121XN01 V0
Resolution	SVGA (1024 x 768)
Active Area (mm)	245.76 x 184.32
Pixel Pitch (mm)	0.3075
Mode	TN
Number of Colors	262K
View Angle (H/V)	160/160
Brightness (cd/m ²)	500
Contrast Ratio	700:1
Response Time (ms) (at 25C)	35
Power Consumption (W)	9.15
Interface	1ch LVDS
Supply Voltage (V)	3.3
Backlight	LED
Color Saturation (NTSC%)	70

Table 3-4: LCD-KIT121GX LCD Specifications

3.1.6 LCD-KIT121G LCD Specifications

The table below lists the LCD-KIT121G LCD specifications.

Model	LCD-KIT121G
Size	12.1"
MFR/Model	AUO/G121SN01 V4
Resolution	SVGA (800 x 600)
Active Area (mm)	245.76 x 184.32
Pixel Pitch (mm)	0.3075
Mode	TN
Number of Colors	262K
View Angle (H/V)	160/140
Brightness (cd/m²)	450
Contrast Ratio	700:1
Response Time (ms) (at 25C)	35
Power Consumption (W)	6.7
Interface	1ch LVDS
Supply Voltage (V)	3.3
Backlight	LED
Color Saturation (NTSC%)	55

Table 3-5: LCD-KIT121G LCD Specifications

3.1.7 LCD-KIT104GH LCD Specifications

The table below lists the LCD-KIT104GH LCD specifications.

Model	LCD-KIT104GH
Size	10.4"
MFR/Model	AUO/G104SN02 V2
Resolution	SVGA (800 x 600)
Active Area (mm)	211.2 x 158.4
Pixel Pitch (mm)	0.264
Mode	TN
Number of Colors	262K
View Angle (H/V)	160 / 140
Brightness (cd/m ²)	400
Contrast Ratio	700:1
Response Time (ms) (at 25C)	30
Power Consumption (W)	5.2
Interface	1ch LVDS
Supply Voltage (V)	3.3
Backlight	LED
Color Saturation (NTSC%)	45

Table 3-6: LCD-KIT104GH LCD Specifications

3.1.8 LCD-KIT84GH LCD Specifications

The table below lists the LCD-KIT84GH LCD specifications.

Model	LCD-KIT84GH
Size	8.4"
MFR/Model	AUO/G084SN05 V8
Resolution	SVGA (800 x 600)
Active Area (mm)	170.4 x 127.8
Pixel Pitch (mm)	0.213
Mode	TN
Number of Colors	262K
View Angle (H/V)	160 / 140
Brightness (cd/m²)	450
Contrast Ratio	600:1
Response Time (ms) (at 25C)	30
Power Consumption (W)	4.2
Interface	LVDS
Supply Voltage (V)	3.3
Backlight	LED
Color Saturation (NTSC%)	45

Table 3-7: LCD-KIT84GH LCD Specifications

3.1.9 LCD-KIT65GH LCD Specifications

The table below lists the LCD-KIT65GH LCD specifications.

Model	LCD-KIT65GH
Size	6.5"
MFR/Model	AUO/G065VN01 V2
Resolution	VGA (640 x 480)
Active Area (mm)	132.48 x 99.36
Pixel Pitch (mm)	0.207
Mode	TN
Number of Colors	262K
Color Saturation (NTSC%)	55
View Angle (H/V)	160/140
Brightness (cd/m²)	800
Contrast Ratio	600:1
Response Time (ms) (at 25C)	25
Power Consumption (W)	3.86
Interface	LVDS
Supply Voltage (V)	3.3
Backlight	LED

Table 3-8: LCD-KIT65GH LCD Specifications

3.2 Power Adapters

Table 3-9 lists the AC/DC power adapter specifications.

LCD-KIT	190G, 170G, 150G, 121G/XG	104GH, 84GH, 65GH
Power	50 Watt AC/DC Adapter	35 Watt AC/DC Adapter
General Description	Universal Input 90 to 264 VAC EMI Meets FCC/CISPR 22 Class B MTBF 165Khrs Limited Power Source	Universal Input 90 to 264 VAC EMI Meets FCC/CISPR 22 Class B MTBF 300Khrs Limited Power Source
Input Voltage Range	90-264VAC	90-264VAC
Input Frequency	47-63 Hz	47-63 Hz
Inrush Current	40A max. (Cold Start)	30A max. (Cold Start)
Hold-up Time	10mS typical	10mS typical
Leakage Current	0.5mA max.	3.5mA max.
Short Circuit Protection	Continuous	Continuous
Over-voltage Protection	Yes	Yes
Continuous Output Power	50W max.	35W max.
Hi-pot Isolation: Input / Output	4242VDC	4242VDC

Table 3-9: Power Adapter Specifications

Chapter

4

AD Boards

4.1 AD Board Overview

The LCD-KIT series industrial LCD monitor AD board provides a wide variety of control interfaces, receiving and managing interface signals from a CPU card through cabling. There are three AD boards used for the LCD-KIT series LCD monitors: AV-9650, AV-6650 and AV-6600. Refer to **Section 1.4** for a listing of LCD-KIT series LCD monitors and their associated AD board. The following sections describe each AD board in detail.

4.2 AV-9650 AD Board Overview

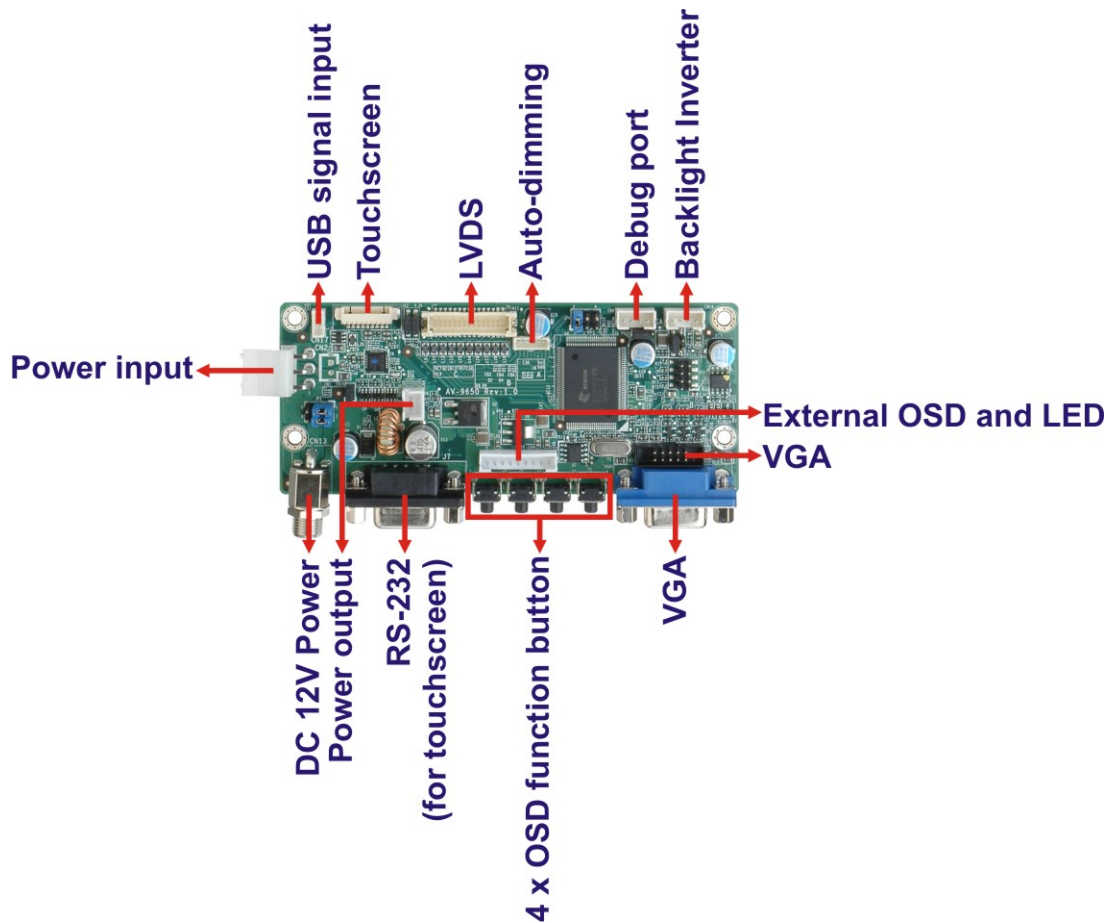

Figure 4-1: AV-9650 AD Board Overview

4.2.1 AV-9650 Peripheral Interface Connectors

Table 4-1 shows a list of the peripheral interface connectors on the AV-9650 AD board.

Connector	Type	Label
Auto-dimming connector	6-pin wafer connector	CN7
Backlight Inverter connector	4-pin wafer connector	CN16
Debug port connector	4-pin wafer connector	CN9
External OSD and LED indication connector	9-pin wafer connector	CN10
LVDS connector	30-pin crimp connector	CN15
Power input connector	3-pin connector	CN2
Power output connector	2-pin wafer connector	CN4
USB signal input connector	4-pin wafer connector	CN17
Touchscreen connector	9-pin wafer connector	J4
VGA connector	10-pin box header	CN14

Table 4-1: AV-9650 Peripheral Interface Connectors

4.2.2 AV-9650 Rear Panel Connectors

Table 4-2 lists the rear panel connectors and buttons on the AV-9650 AD board.

Connector	Type	Label
DC 12V power connector	DC Power Jack	CN13
Serial port connector	RS-232 connector	J7
OSD function button	Pushbutton	S1
OSD function button	Pushbutton	S2
OSD function button	Pushbutton	S3
OSD function button	Pushbutton	S4
VGA connector	15-pin VGA connector	VGA1

Table 4-2: AV-9650 Rear Panel Connectors

4.3 AV-6650 AD Board Overview

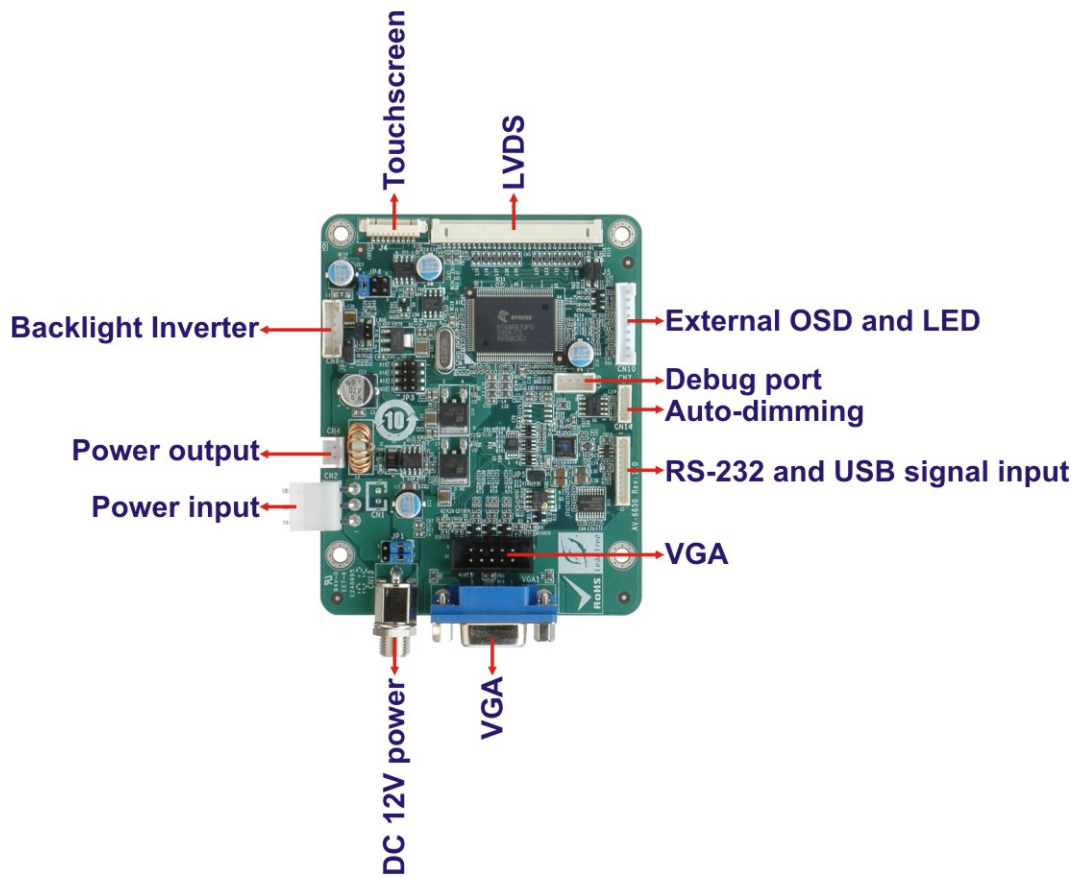

Figure 4-2: AV-6650 AD Board Overview

4.3.1 AV-6650 Peripheral Interface Connectors

Table 4-3 shows a list of the peripheral interface connectors on the AV-6650 AD board.

Connector	Type	Label
Auto-dimming connector	6-pin wafer connector	CN7
Backlight inverter connector	6-pin wafer connector	CN6
Debug port connector	4-pin wafer connector	CN9
External OSD and LED indication connector	9-pin wafer connector	CN10
LVDS output connector	30-pin connector	CN5
Power output connector	2-pin header	CN4
Power input connector	3-pin connector	CN2
RS-232 and USB signal input connector	12-pin wafer connector	CN14
Touchscreen connector	9-pin wafer connector	J4
VGA connector	10-pin box header	VGA2

Table 4-3: AV-6650 Peripheral Interface Connectors

4.3.2 AV-6650 Rear Panel Connectors

Table 4-4 lists the rear panel connectors and jumpers on the AV-6650 AD board.

Connector	Type	Label
DC 12V power connector	DC Power Jack	CN13
VGA connector	15-pin VGA connector	VGA1

Table 4-4: AV-6650 Rear Panel Connectors

4.4 AV-6600 AD Board Overview

The AV-6600 AD board provides a wide variety of control interfaces, receiving and managing interface signals from a CPU card through cabling. The following sections describe the AV-6600 AD board in detail.

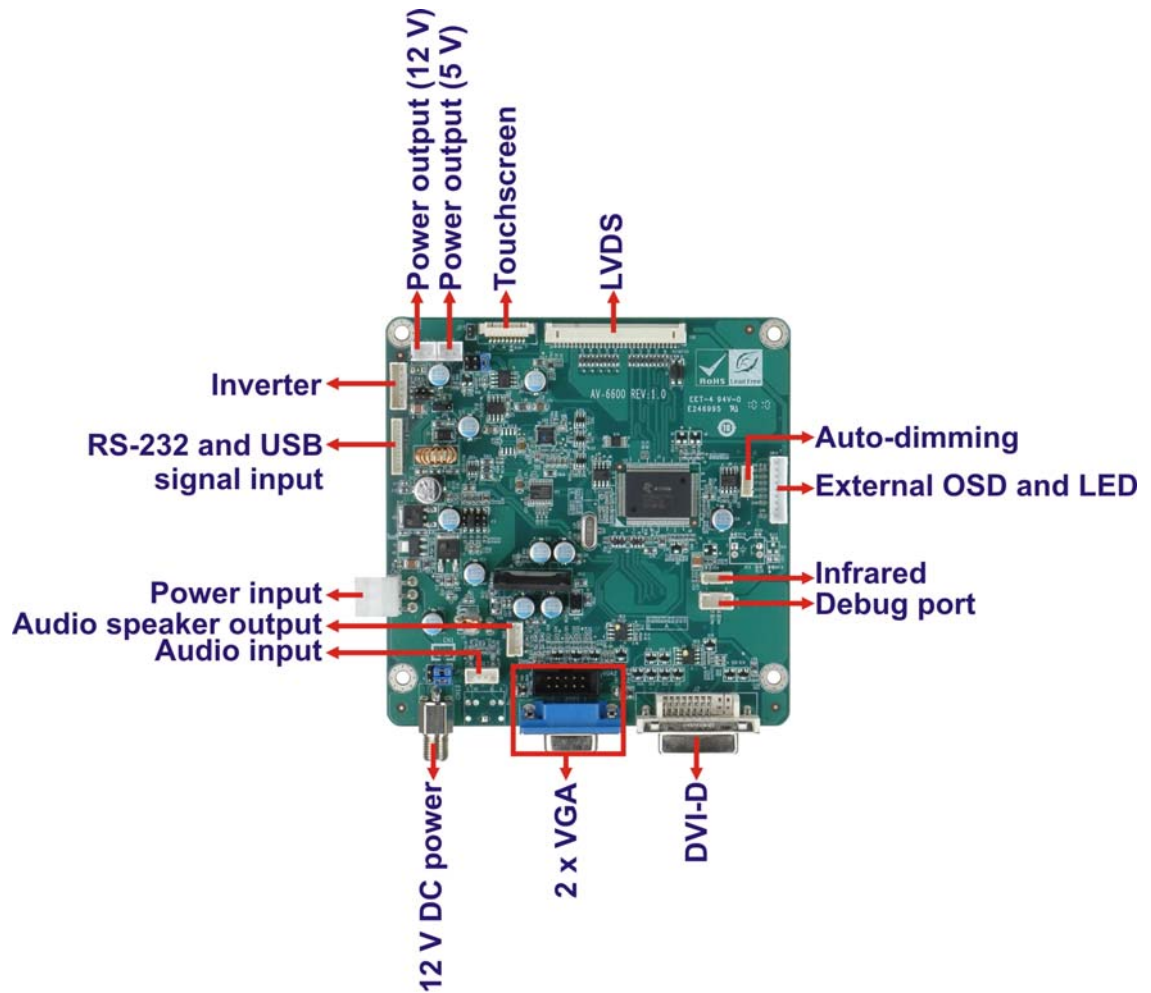

Figure 4-3: AV-6600 AD Board Overview

4.4.1 AV-6600 Peripheral Interface Connectors

Table 4-5 shows a list of the peripheral interface connectors on the AV-6600 AD board.

Connector	Type	Label
Audio input connector	4-pin wafer connector	CN11
Audio speaker output connector	4-pin wafer connector	CN12
Auto-dimming connector	6-pin wafer connector	CN7
Debug connector	4-pin wafer connector	CN9
External OSD and LED indication connector	9-pin wafer connector	CN10

Infrared connector	6-pin wafer connector	CN8
Inverter interface connector	6-pin wafer connector	CN6
LVDS connector	30-pin connector	CN5
Power output connector (+12 V)	2-pin wafer connector	CN3
Power output connector (+5 V)	2-pin wafer connector	CN4
Power input connector	3-pin connector	CN2
RS-232 and USB signal input connector	12-pin wafer connector	CN14
Touchscreen connector	9-pin wafer connector	J4
VGA connector	10-pin box header	VGA2

Table 4-5: AV-6600 Peripheral Interface Connectors

4.4.2 AV-6600 Rear Panel Connectors

Table 4-6 lists the rear panel connectors on the AV-6600 AD board.

Connector	Type	Label
12V DC power connector	DC Power Jack	CN13
DVI connector	24-pin DVI-D connector	J2
VGA connector	15-pin VGA connector	VGA1

Table 4-6: AV-6600 Rear Panel Connectors

Chapter

5

Installation

5.1 Installation Precautions

When installing the LCD-KIT series LCD monitor, please follow the precautions listed below:

- **Read the user manual:** The user manual provides a complete description of the LCD-KIT series LCD monitor, installation instructions and configuration options.
- **DANGER! Disconnect Power:** Power to the LCD monitor must be disconnected when installing the LCD-KIT series LCD monitor, or before any attempt is made to access the rear panel. Electric shock and personal injury might occur if the rear panel of the monitor is opened while the power cord is still connected to an electrical outlet.
- **Qualified Personnel:** The LCD-KIT series LCD monitor must be installed and operated only by trained and qualified personnel. Maintenance, upgrades, or repairs may only be carried out by qualified personnel who are familiar with the associated dangers.
- **Mounting:** Since the monitor may weigh up to 10 kg (not including a swing arm or other accessories), please ensure at least two people assist with mounting the monitor.
- **Air Circulation:** Make sure there is sufficient air circulation when installing the monitor. The monitor's cooling vents must not be obstructed by any objects. Blocking the vents can cause overheating of the monitor. Leave at least 5 cm of clearance around the monitor to prevent overheating.
- **Grounding:** The monitor should be properly grounded. The voltage feeds must not be overloaded. Adjust the cabling and provide external overcharge protection per the electrical values indicated on the label attached to the back of the monitor.
- **Anti-static Discharge:** The rear panel of the monitor must to be removed to configure the monitor's AD board voltage select jumper. When doing so, be sure the monitor is disconnected from its power source and take all necessary safety precautions to avoid electrocution and static discharge to the AD board. The use of a grounded wrist strap and an anti-static work pad is recommended.

LCD-KIT

5.2 Unpacking

5.2.1 Packaging

When shipped, the LCD-KIT series LCD monitor is wrapped in a plastic bag. Two polystyrene ends are placed on either side of the monitor. The monitor is then placed into a first (internal) cardboard box. This box is then sealed and placed into a second (external) cardboard box. The second box is also sealed. A bag containing accessory items is placed with the monitor in the internal (first) box.

5.2.2 Unpacking Procedure

To unpack the LCD-KIT series LCD monitor, follow the steps below:



WARNING:

The front side LCD screen has a protective plastic cover stuck to the screen. Only remove the plastic cover after the LCD-KIT series LCD monitor has been properly installed. This ensures the screen is protected during the installation process.

- Step 1:** Use box cutters, a knife or a sharp pair of scissors that seals the top side of the external (second) box.
- Step 2:** Open the external (second) box.
- Step 3:** Use box cutters, a knife or a sharp pair of scissors that seals the top side of the internal (first) box.
- Step 4:** Lift the monitor out of the boxes.
- Step 5:** Remove both polystyrene ends, one from each side.
- Step 6:** Pull the plastic cover off the LCD-KIT series LCD monitor.
- Step 7:** Make sure all the components listed in the packing list are present.

5.2.3 Packing List

All the monitors in the LCD-KIT series are shipped with the following components:

- 1 x LCD-KIT series LCD monitor.
- 1 x AC Power cable
- 1 x VGA Cable
- 1 x 50W AC Power Adapter (LCD-KIT190G / 170 / 150 / 121)
- 1 x 35W AC Power Adapter (LCD-KIT104GH / 84 / 65)
- 5 x Replacement Round Head Screw
- 5 x Replacement Flat Head Screw
- 5 x Replacement Wire Strain Band
- 1 x User Manual on CDROM

If any of these items are missing or damaged, contact the distributor or sales representative immediately.

5.3 Pre-installation Preparation

5.3.1 Tools

Before installing the LCD-KIT series LCD monitor, make sure the following tools are on hand:

- **Philips (crosshead) screwdriver:** All the retention screws on the system are Philips screws.
- **Soft working mat:** When the LCD-KIT series LCD monitor is installed, the screen is placed on the working surface. It is therefore important to rest the MPC industrial workstation on a soft mat that cannot damage the LCD screen on the front of the LCD-KIT series LCD monitor.

5.4 Connectors

Table 5-1 lists the rear panel connectors for the LCD-KIT series LCD monitors.

LCD-KIT	65GH	84GH	104GH	121G/GX	150G	170G	190G
DVI-D	-			Yes			
VGA	Yes						
Power (12V Jack)	Yes						

Table 5-1: Rear Panel Connectors

5.4.1 VGA Connector

Use the rear panel standard 15-pin female VGA connector to connect the LCD monitor to the system graphics interface.

Pin	Description	Pin	Description	Pin	Description
1	RED	6	GROUND	11	NC
2	GREEN	7	GROUND	12	DDCDAT
3	BLUE	8	GROUND	13	HSYNC
4	NC	9	NC	14	VSYNC
5	GROUND	10	GROUND	15	DDCCLK

Table 5-2: VGA Connector Pinouts

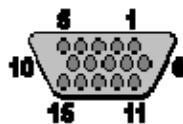

Figure 5-1: VGA Connector

5.4.2 DVI-D Connector

Use the rear panel standard 24-pin female DVI-D connector to connect the LCD monitor to the system graphics interface.

Pin	Description	Pin	Description	Pin	Description
1	TMDS Data2-	9	TMDS Data1-	17	TMDS Data0-
2	TMDS Data2+	10	TMDS Data1+	18	TMDSData0+
3	TMDS Data2/4 Shield	11	TMDS Data1/3 Shield	19	TMDS Data0/5 Shield
4	TMDS Data4-	12	TMDS Data3-	20	TMDS Data5-
5	TMDS Data4+	13	TMDS Data3+	21	TMDS Data5+
6	DDC Clock [SCL]	14	+5 V Power	22	TMDS Clock Shield
7	DDC Data [SDA]	15	Ground (for +5 V)	23	TMDS Clock +
8	Analog vertical sync	16	Hot Plug Detect	24	TMDS Clock -

Table 5-3: DVI-D Connector Pinouts

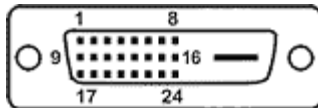

Figure 5-2: DVI-D Connector

5.4.3 12V Power Connector

Use the rear panel +12V DC (or 9~36V DC on M models) jack to connect the monitor to a power source.

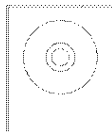

Figure 5-3: 12V Power Connector

5.5 Mounting the LCD-KIT Series LCD Monitor

Each LCD-KIT series LCD monitor comes with a preinstalled mounting bracket with a number of holes available for mounting purposes that system integrators will find especially useful. Refer to **Sections 2.4** and **2.5** for further details on the number and location of mounting holes for each model of the LCD-KIT series LCD monitor.

Chapter

6

OSD Controls

6.1 User Mode OSD Structure

6.1.1 OSD Buttons

There are several on-screen-display (OSD) control buttons oriented either vertically along the right hand side or horizontally along the bottom of the monitor front panel. Refer to **Section 2.2** for availability and orientation of the OSD controls on specific LCD-KIT series LCD monitors.

Figure 6-1 shows a typical arrangement of OSD controls for all models except the 6.5" model.

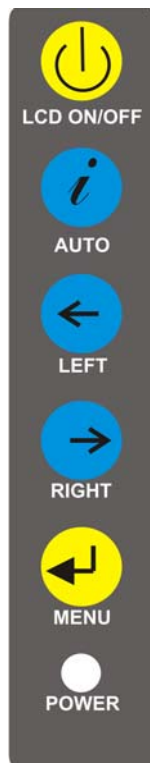

Figure 6-1: OSD Control Buttons (Except 6.5")

Figure 6-2 shows the OSD controls for the 6.5".

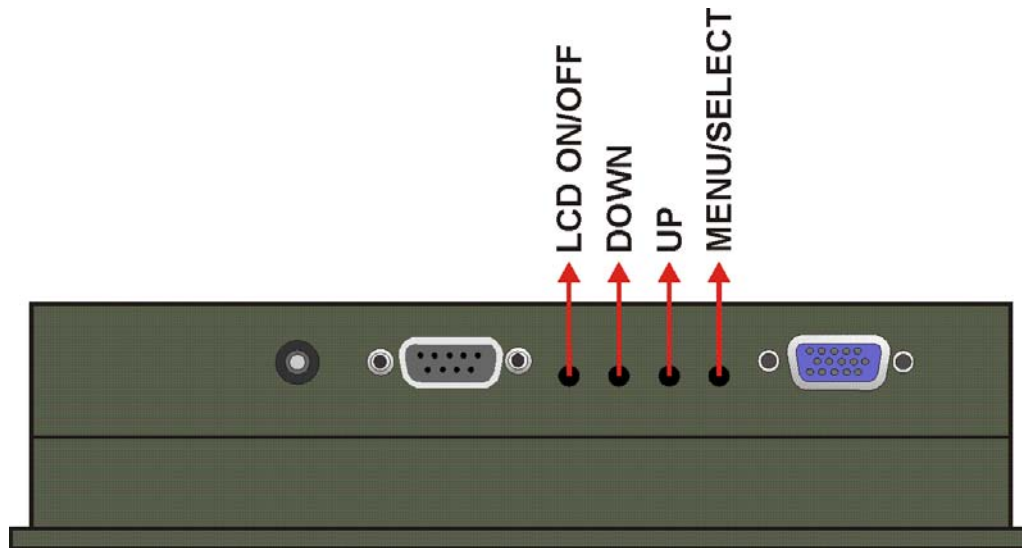

Figure 6-2: LCD-KIT65 OSD Control Buttons

6.1.2 OSD Menu Structure

Table 6-1 shows the OSD menu structure for all models of the SRM series LCD monitor.

Level 0	Level 1	Value
Main Display Features Menu	Brightness	0 to 100
	Contrast	0 to 100
	Clock	0 to 100
	Phase	0 to 100
	H. Position	0 to 100
	V. Position	0 to 100
	Sharpness	1 to 5
Color Menu	6500K	- Preset NTSC value
	7500K	- Preset NTSC value
	9300K	- Preset NTSC value
	Red	RGB values from 0 to 100
	Green	RGB values from 0 to 100
	Blue	RGB values from 0 to 100
OSD Menu	OSD Time Out	0 to 60 sec
	OSD Position	1 to 5
	OSD Transparency	20, 40, 60, 80, 100

	Factory Reset	Select
	Auto Adjust	Select
	Auto Color	Select
	Gamma	Off, On
Exit Menu	Exit	Select

Table 6-1: OSD Menus

6.2 Using the OSD

OSD menu options are described below.

6.2.1 Main Display Features

Main display features are shown in **Figure 6-3**.



Figure 6-3: Main Display Features

Brightness

The brightness option adjusts the brightness of screen. This function adjusts the offset value of ADC. Setting this value too high or too low will affect the quality of image. When the auto- dimming function is turned on, the brightness control is not effective.

Contrast

This function adjusts the gain value of ADC. Adjusting this value too high or too low will worsen the quality of image.

Clock

Adjusts the width of the display screen.

LCD-KIT

Phase	Adjusts the input signal.
H. Position	Adjusts the horizontal position of the display screen.
V. Position	Adjusts the vertical position of the display screen
Sharpness	Adjust the sharpness of the display

6.2.2 Color

Color options are shown in **Figure 6-4**.

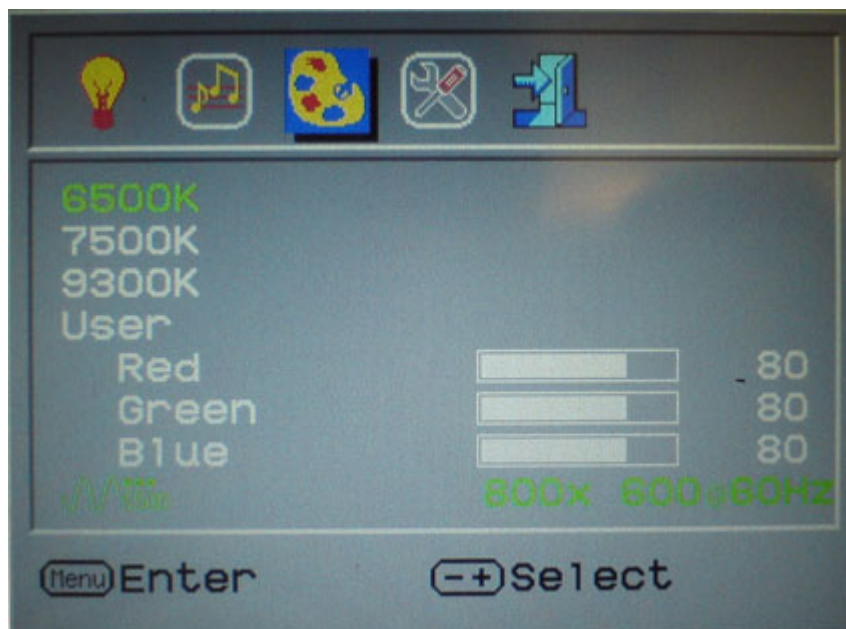

Figure 6-4: Color Options

The Color menu fine-tunes the palette of color hues for the LCD.

6500k	NTSC standard Kelvin
7500k	NTSC standard Kelvin
9300k	NTSC standard Kelvin
User	This item allows fine-tuning the balance among Red, Green, and Blue color hues if images look garish or unrealistic.

6.2.3 OSD Configurations

The OSD configurations are shown in **Figure 6-5**.

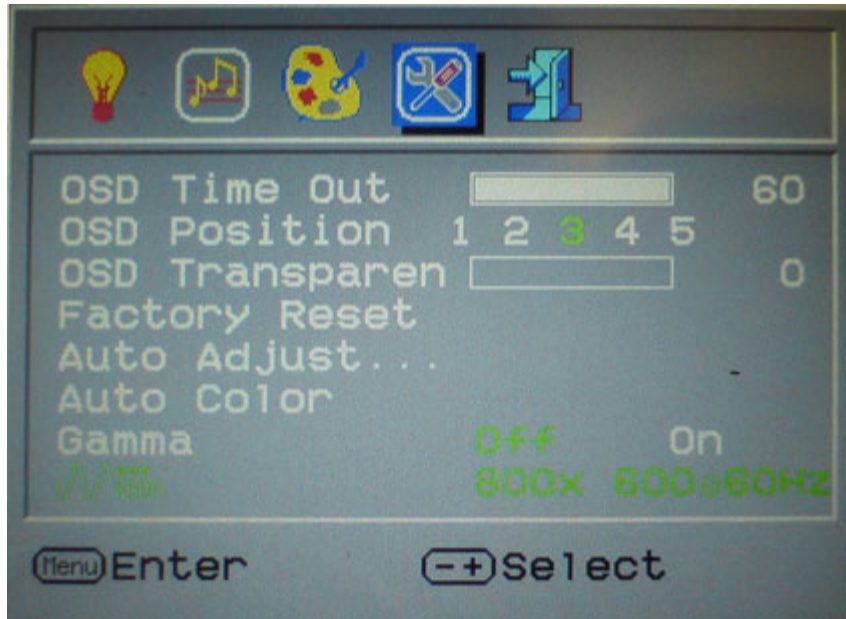

Figure 6-5: OSD Configurations Menu

OSD Configurations are described below.

- | | |
|-------------------------|--|
| OSD Time Out | Determines how many seconds the OSD screen stays on screen before it disappears when OSD is left unattended. |
| OSD Position | Adjusts the OSD position on the screen. Position 1 is in the upper left of the screen, position 2 in the upper right and position 3 in the center. |
| OSD Transparency | Adjust the transparency of the OSD menu background. |
| Factory Reset | Restores the default OSD settings. Note that this will restore all default display settings. |
| Auto Adjust | Automatically adjusts the position of the display screen |
| Auto Color | Automatically adjusts the color settings. |

Chapter

7

Software Driver

7.1 Introduction

The touch panel controller enables analog resistive touch panels for four-wire, five-wire & eight-wire models. The controller directly communicates with the PC system through the touch panel communications interface. The controller design is superior in sensitivity, accuracy, and friendly operation. The touch panel driver emulates the left mouse button and the right mouse button functions.

The touch panel driver supports the following operating systems:

- Microsoft® Windows® versions:
 - Microsoft® Windows® 2000
 - Microsoft® Windows® XP
 - Microsoft® Windows® 2003
 - Microsoft® Windows® 2008
 - Microsoft® Windows® Vista
 - Microsoft® Windows® 7
- Microsoft® Windows® CE versions:
 - Microsoft® Windows® CE 4.2
 - Microsoft® Windows® CE 5.0
 - Microsoft® Windows® CE 6.0
- Linux Kernel 2.6
- DOS

Driver installation is described below.

7.2 RS-232 or USB Touch Screen

Before installing the driver, connect the LCD-KIT monitor to the motherboard. The LCD-KIT monitors support touch screen modality through an RS-232 or USB interface connection. Decide through which interface the touch screen is to be controlled.

- **RS-232 Interface:** If the touch screen interface connection is an RS-232 connection, connect the RS-232 connector on the single board computer to the DB-9 connector of the LCD-KIT monitor.

LCD-KIT

- **USB Interface:** If the touch screen interface connection is a USB connection, connect the USB connector on the single board computer to the external USB port connector of the LCD-KIT monitor.

7.3 Touch Panel Driver Installation



WARNING:

Before the touch screen driver is installed, make sure the system is connected to the monitor with a USB cable or an RS-232 null cable. Also, make sure the VGA connector on the system is connected to the VGA connector on the bottom of the monitor.

To install the touch panel driver for the LCD-KIT, please follow the instructions below:

- Step 1:** Connect the LCD-KIT monitor to the single board computer. See above.
- Step 2:** Install the driver CD. Install the driver CD into the system to which the LCD-KIT monitor is connected.
- Step 3:** Select the **Touch Screen** option in the menu of driver CD. The directory in **Figure 7-1** appears.

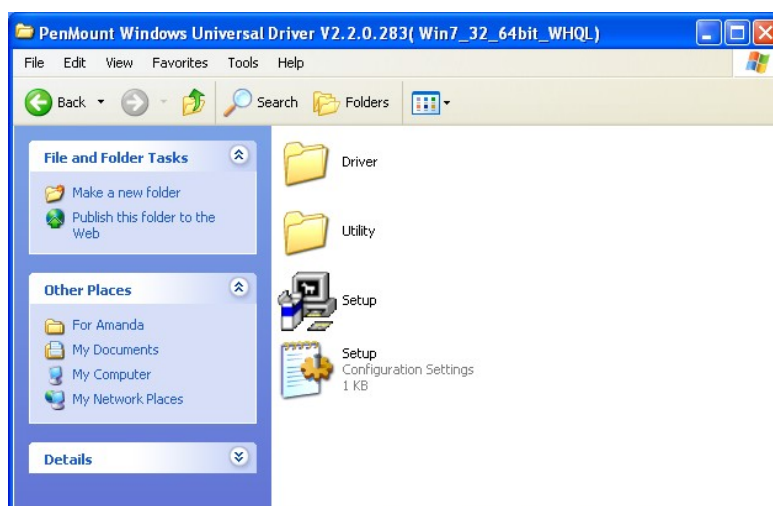

Figure 7-1: Setup Icon

Step 4: Double click the setup icon in **Figure 7-1**.

Step 5: The Welcome screen in **Figure 7-2** appears.



Figure 7-2: Welcome Screen

Step 6: Click **Next** to continue.

Step 7: The license agreement in **Figure 7-3** appears. Accept the terms of the agreement by clicking **I Agree**.

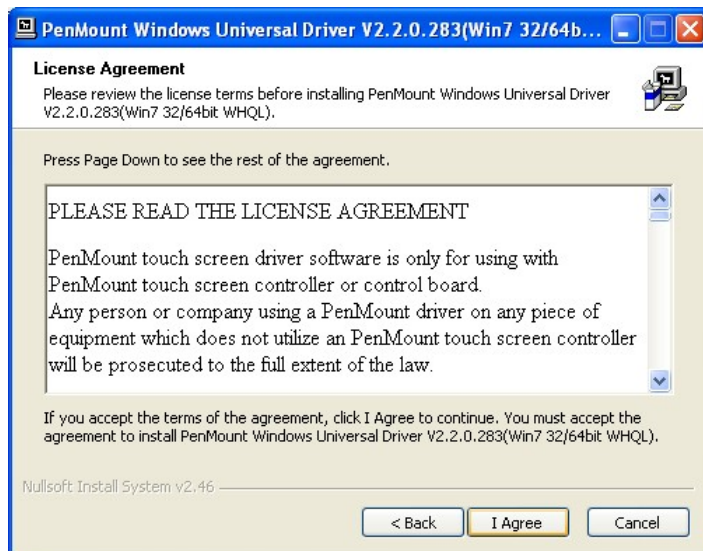

Figure 7-3: License Agreement

Step 8: The installation destination screen appears. See **Figure 7-4**. Click **Install**.

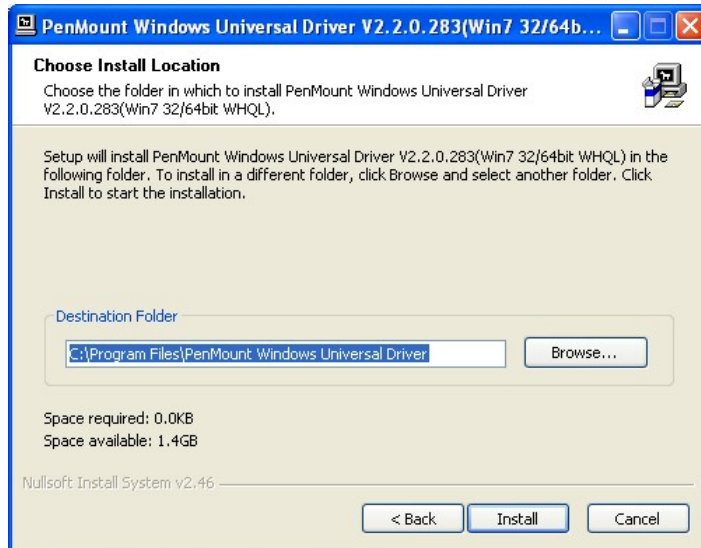

Figure 7-4: Initiate Install

Step 9: The installation of the program begins. See **Figure 7-5**.

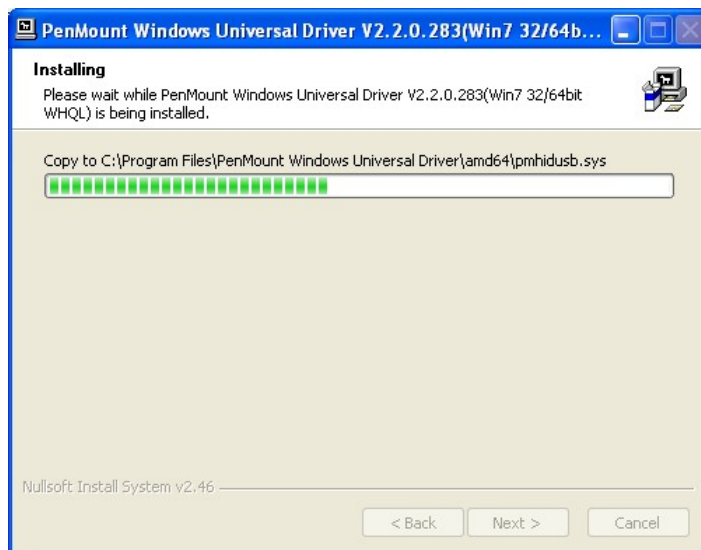

Figure 7-5: Installation Starts

Step 10: When the installation is complete, the complete screen appears. See **Figure 7-6**.

To complete the installation process click **Finish**.

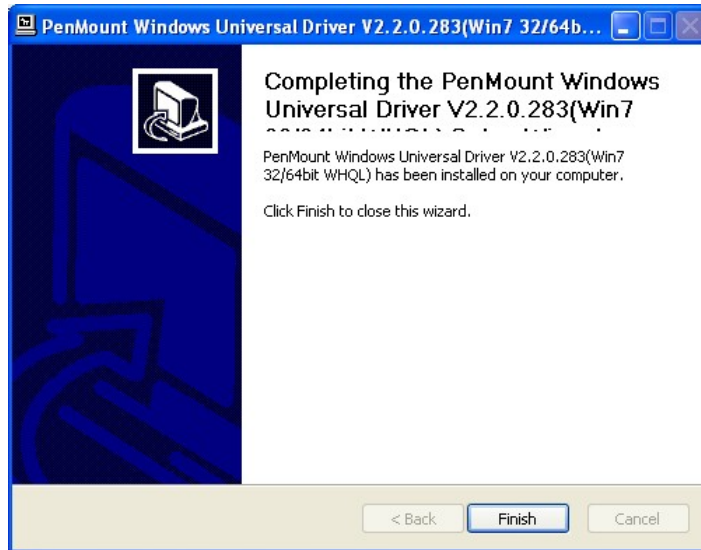

Figure 7-6: Finish Installation

7.4 Change the Touch Screen Interface

If the touch screen interface must be changed from an RS-232 interface to a USB interface or, from a USB interface to an RS-232 interface, the following steps must be followed.

- Step 1:** Uninstall the touch screen driver
- Step 2:** Remove the interface cable i.e. remove the RS-232 cable or the USB cable
- Step 3:** Install the new cable i.e. install the USB cable or the RS-232 cable.
- Step 4:** Reinstall the driver CD as described above.

7.5 Calibrating the Touch Screen

To calibrate the touch screen cursor with the motion of the touch screen pen (or finger), please follow the steps below:

- Step 1:** Make sure the system is properly connected through an RS-232 or a USB interface to the LCD-KIT monitor.
- Step 2:** Make sure the touch screen driver is properly installed.

LCD-KIT

Step 3: Locate the PenMount Monitor icon in the bottom left corner of the screen.



Figure 7-7: PenMount Monitor Icon

Step 4: Click the icon. A pop up menu appears. See **Figure 7-8**.

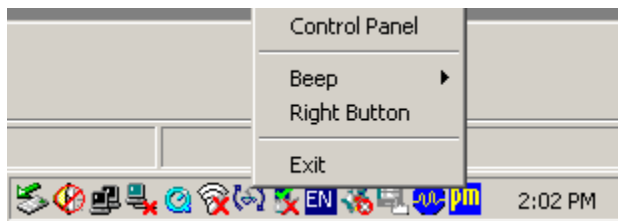

Figure 7-8: PenMount Monitor Popup Menu

Step 5: Click Control Panel in the pop up menu shown in **Figure 7-8**.

Step 6: The configuration screen in **Figure 7-9** appears.

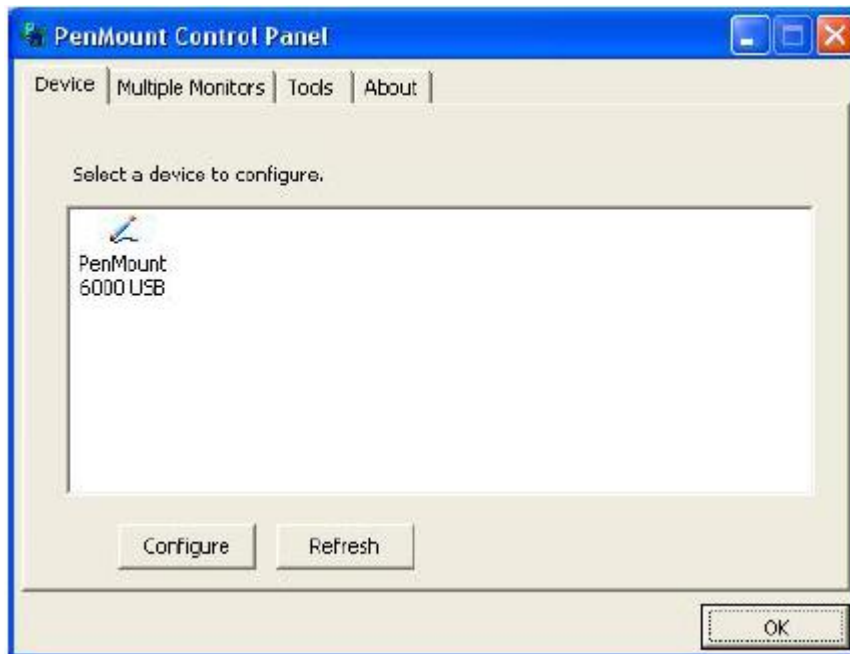

Figure 7-9: Configuration Screen

Step 7: Double click the PenMount 6000 icon as shown in **Figure 7-9**.

Step 8: The calibration initiation screen in **Figure 7-10** appears.

Step 9: Select the Standard Calibration button as shown in **Figure 7-10**.



Figure 7-10: Calibration Initiation Screen

Step 10: The calibration screen in is shown. See **Figure 7-11**.

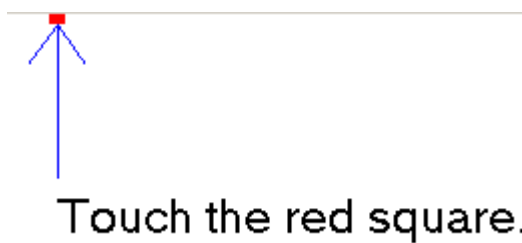

Figure 7-11: Calibration Screen

Step 11: Follow the instructions. The user is asked touch the screen at five specified points after which the screen is calibrated.

Appendix

A

Certifications

A.1 RoHS Compliant

All models in the LCD-KIT series comply with the Restriction of Hazardous Materials (RoHS) Directive. This means that all components used to build the industrial workstations and the workstation itself are RoHS compliant.

The RoHS Directive bans the placing on the EU market of new electrical and electronic equipment containing more than agreed levels of lead, cadmium, mercury, hexavalent chromium, polybrominated biphenyl (PBB) and polybrominated diphenyl ether (PBDE) flame retardants.

Appendix

B

Safety Precautions

**WARNING:**

The precautions outlined in this chapter should be strictly followed. Failure to follow these precautions may result in permanent damage to the LCD-KIT Series.

B.1 Safety Precautions

Please follow the safety precautions outlined in the sections that follow:

B.1.1 General Safety Precautions

Please ensure the following safety precautions are adhered to at all times.

- **Follow the electrostatic precautions** outlined below whenever the LCD-KIT Series is opened.
- **Make sure the power is turned off and the power cord is disconnected** whenever the LCD-KIT Series is being installed, moved or modified.
- **Do not apply voltage levels that exceed the specified voltage range.** Doing so may cause fire and/or an electrical shock.
- **Electric shocks can occur** if the LCD-KIT Series chassis is opened when the LCD-KIT Series is running.
- **Do not drop or insert any objects** into the ventilation openings of the LCD-KIT Series.
- **If considerable amounts of dust, water, or fluids enter the** LCD-KIT Series, turn off the power supply immediately, unplug the power cord, and contact the LCD-KIT Series vendor.
- **DO NOT:**
 - Drop the LCD-KIT Series against a hard surface.
 - Strike or exert excessive force onto the LCD panel.
 - Touch any of the LCD panels with a sharp object
 - In a site where the ambient temperature exceeds the rated temperature

B.1.2 Anti-static Precautions



WARNING:

Failure to take ESD precautions during the installation of the LCD-KIT Series may result in permanent damage to the LCD-KIT Series and severe injury to the user.

Electrostatic discharge (ESD) can cause serious damage to electronic components, including the LCD-KIT Series. Dry climates are especially susceptible to ESD. It is therefore critical that whenever the LCD-KIT Series is opened and any of the electrical components are handled, the following anti-static precautions are strictly adhered to.

- **Wear an anti-static wristband:** Wearing a simple anti-static wristband can help to prevent ESD from damaging any electrical component.
- **Self-grounding:** Before handling any electrical component, touch any grounded conducting material. During the time the electrical component is handled, frequently touch any conducting materials that are connected to the ground.
- **Use an anti-static pad:** When configuring or working with an electrical component, place it on an anti-static pad. This reduces the possibility of ESD damage.
- **Only handle the edges of the electrical component:** When handling the electrical component, hold the electrical component by its edges.

B.2 Maintenance and Cleaning Precautions

When maintaining or cleaning the LCD-KIT Series, please follow the guidelines below.

B.2.1 Maintenance and Cleaning

Prior to cleaning any part or component of the LCD-KIT Series, please read the details below.

- Except for the LCD panel, never spray or squirt liquids directly onto any other components. To clean the LCD panel, gently wipe it with a piece of soft dry cloth or a slightly moistened cloth.
- The interior of the LCD-KIT Series does not require cleaning. Keep fluids away from the LCD-KIT Series interior.
- Be cautious of all small removable components when vacuuming the LCD-KIT Series.
- Turn the LCD-KIT Series off before cleaning the LCD-KIT Series.
- Never drop any objects or liquids through the openings of the LCD-KIT Series.
- Be cautious of any possible allergic reactions to solvents or chemicals used when cleaning the LCD-KIT Series.
- Avoid eating, drinking and smoking within vicinity of the LCD-KIT Series.

B.2.2 Cleaning Tools

Some components in the LCD-KIT Series may only be cleaned using a product specifically designed for the purpose. In such case, the product will be explicitly mentioned in the cleaning tips. Below is a list of items to use when cleaning the LCD-KIT Series.

- **Cloth** – Although paper towels or tissues can be used, a soft, clean piece of cloth is recommended when cleaning the LCD-KIT Series.
- **Water or rubbing alcohol** – A cloth moistened with water or rubbing alcohol can be used to clean the LCD-KIT Series.
- **Using solvents** – The use of solvents is not recommended when cleaning the LCD-KIT Series as they may damage the plastic parts.
- **Vacuum cleaner** – Using a vacuum specifically designed for computers is one of the best methods of cleaning the LCD-KIT Series. Dust and dirt can restrict the airflow in the LCD-KIT Series and cause its circuitry to corrode.
- **Cotton swabs** - Cotton swaps moistened with rubbing alcohol or water are excellent tools for wiping hard to reach areas.
- **Foam swabs** - Whenever possible, it is best to use lint free swabs such as foam swabs for cleaning.

Appendix

C

smartOSD

C.1 IEI smartOSD Quick Installation Guide

IEI smartOSD is a proprietary On-Screen-Display (OSD) software solution from IEI that enables easy, remote monitor setting adjustments in a Windows environment. IEI smartOSD delivers excellent performance and provides more flexibility than the typical OSD hardware solutions when adjusting a monitor. smartOSD also allows monitor settings such as brightness, contrast, screen position, size, and color gain to be read and changed over normal video cable (VGA or DVI). The smartOSD function is only supported by revision 1.1 models and above.

C.2 Pre-installation Notice

Before installing smartOSD software, please make sure one of the following operating systems is installed:

- Windows 95
- Windows NT 4.0
- Windows 98
- Windows 2000
- Windows 2003
- Windows XP
- Windows Vista

C.3 smartOSD Install

Connect the LCD-KIT to a host computer. Insert the CD that came with the system and follow the instructions below.

Step 1: When the CD installs the screen shown in Figure C-1 appears.



Figure C-1: smartOSD Installer

Step 2: Click “Smart OSD” in Figure C-1.

Step 3: The welcome screen shown in Figure C-2 appears.

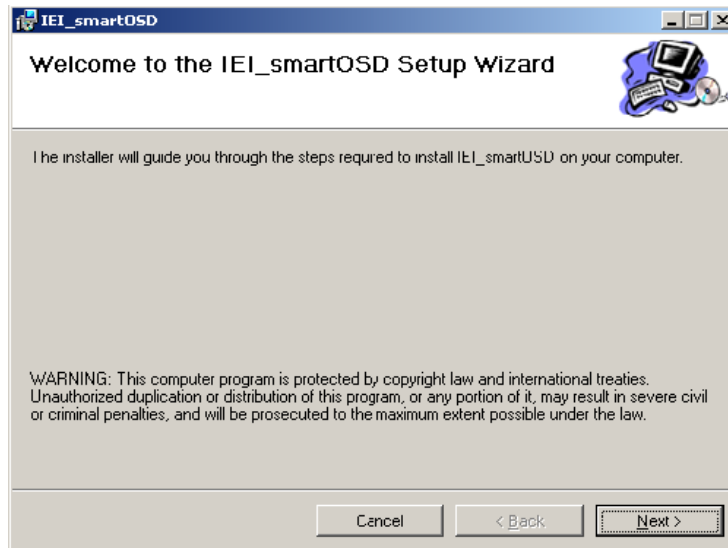

Figure C-2: smartOSD Welcome Screen

Step 4: Click **Next** to continue.

Step 5: The Folder Select screen in Figure C-3 appears.

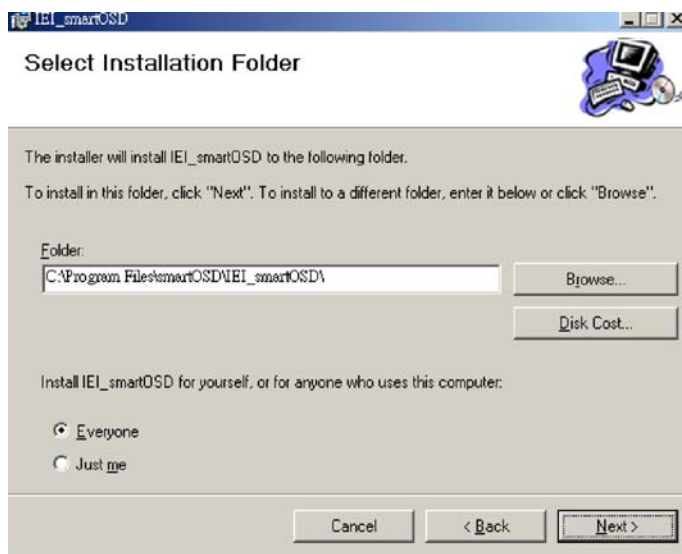

Figure C-3: smartOSD Folder Select Screen

Step 6: Select the installation folder in Figure C-3 shown above.

Step 7: Click **Next** to continue.

Step 8: The screen in Figure C-4 appears.

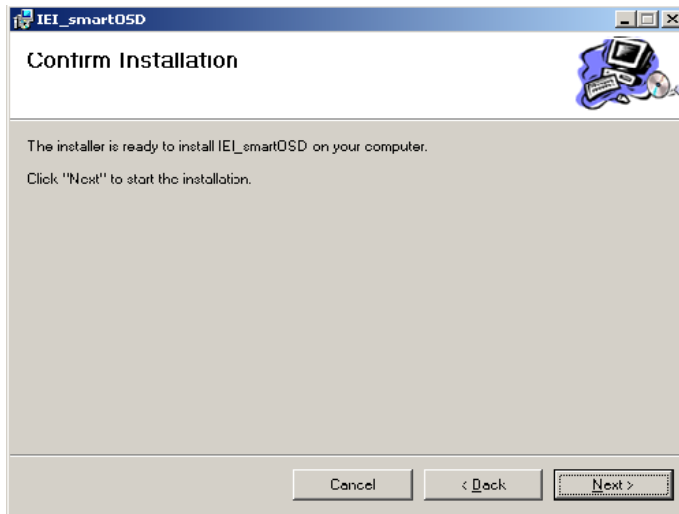

Figure C-4: smartOSD Confirm Installation

Step 9: Confirm the installation by clicking **Next** in the screen above.

Step 10: The program starts to install and the progress bar shown in Figure C-5 appears.

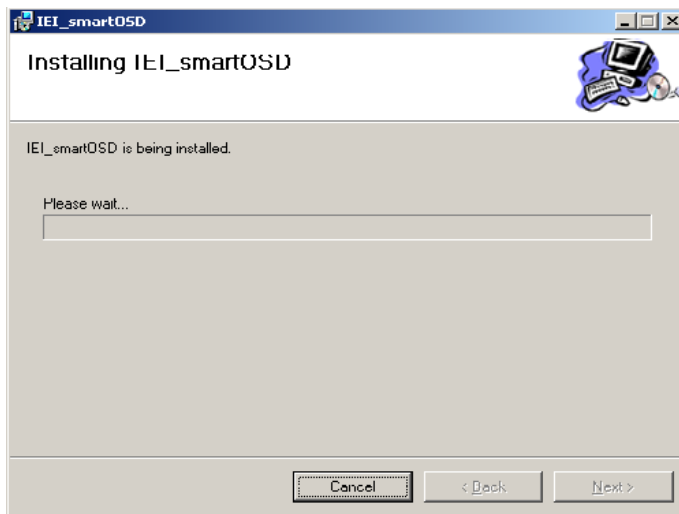

Figure C-5: smartOSD Installation Progress

Step 11: When the installation is complete the “Complete Installation” screen in Figure C-6 appears.

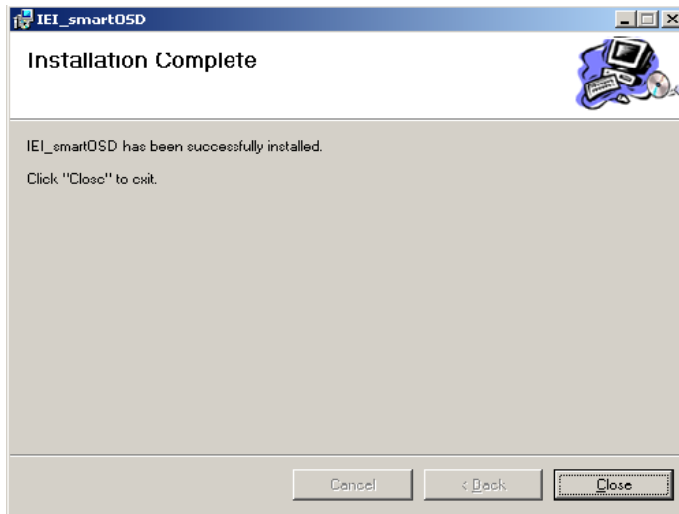

Figure C-6: smartOSD Installation Complete

Step 12: Click **Close** in the screen above.

Step 13: After quick setup is complete, the IEI smartOSD wizard logo appears on the desktop as shown in the screen below.

Step 14: To access the smartOSD, click the smartOSD wizard logo.



Figure C-7: smartOSD Desktop Icon

C.4 Software Illustration

The table below shows the smartOSD menu structure for all IEI LCD monitors.



NOTE:

To update the display setting status immediately, push the refresh button on every page

To turn the system on, press ALT + P.

Item	Elements
Management	Save/Load File
	Power Management
EDID	EDID contains basic information about the monitor and its capabilities.
Image	Brightness
	Contrast
	Sharpness
Display	Auto Adjust
	Phase
	Clock
Color	Auto Color
	User Red Gain
	User Green Gain
	User Blue Gain
	Color Temperature (5000k and 4200k disabled in the LCD-KIT Series)
	Gamma
PIP	PIP (disabled in the LCD-KIT Series)

Item	Elements
	PIP Source Input (disabled in the LCD-KIT Series)
	PIP Size (disabled in the LCD-KIT Series)
System	Monitor Power Control
	Auto Brightness (disabled in the LCD-KIT Series)
	Main Source Input (S-Video and CVBS disabled)
	Volume (disabled in the LCD-KIT Series)
	Factory Presets/OSD Lock/OSD Unlock
	Mute (disabled in the LCD-KIT Series)

Table C-1: SmartOSD Menu Structure

C.4.1 Manage Page



Save the preferred settings of all the OSD functions as .dat files and load the settings.

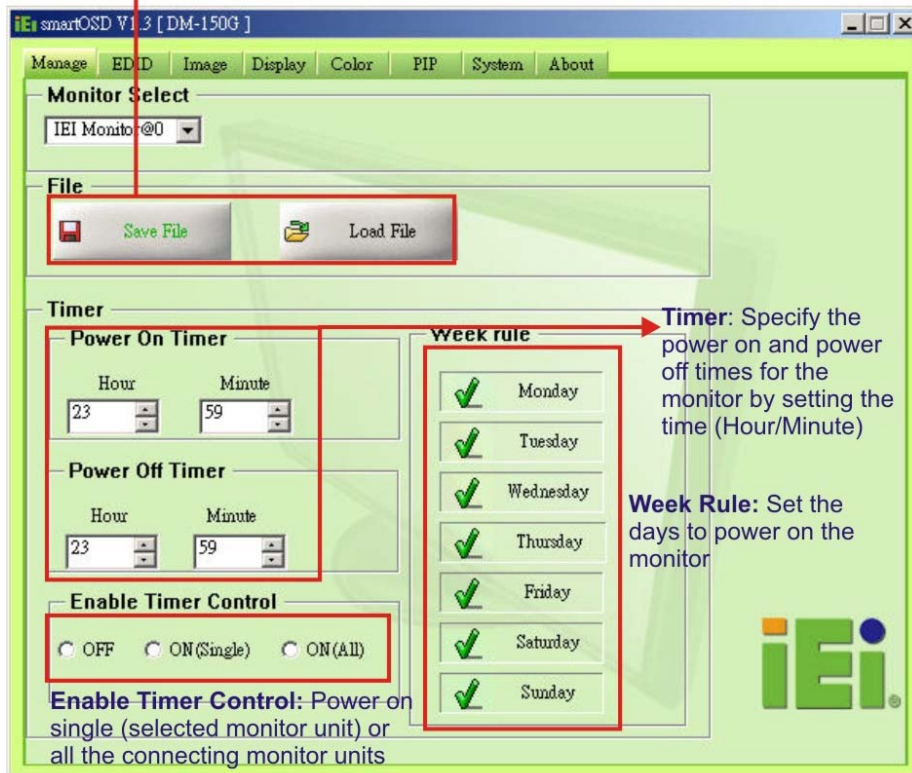

Figure C-8: Manage Page

C.4.2 EDID Page

Caption: Shows the smartOSD version and model name.

Monitor Select: Selects the monitor unit for EDID information reading

Refresh: Updates EDID information

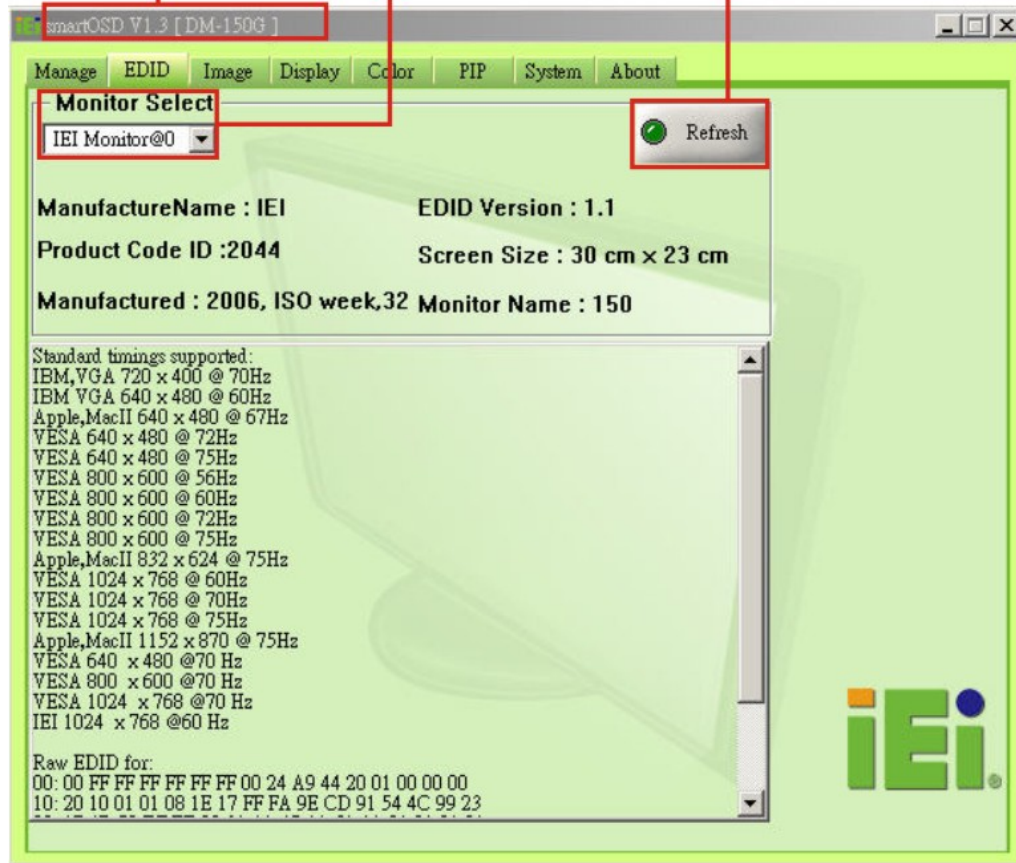

Figure C-9: EDID Page

LCD-KIT

C.4.3 Image Page

Monitor Select: Selects the monitor unit for which the image parameters will be adjusted

Refresh: To update image information which has been affected by the hardware OSD settings

Apply All: Delivering the image parameters settings to all the connecting monitors

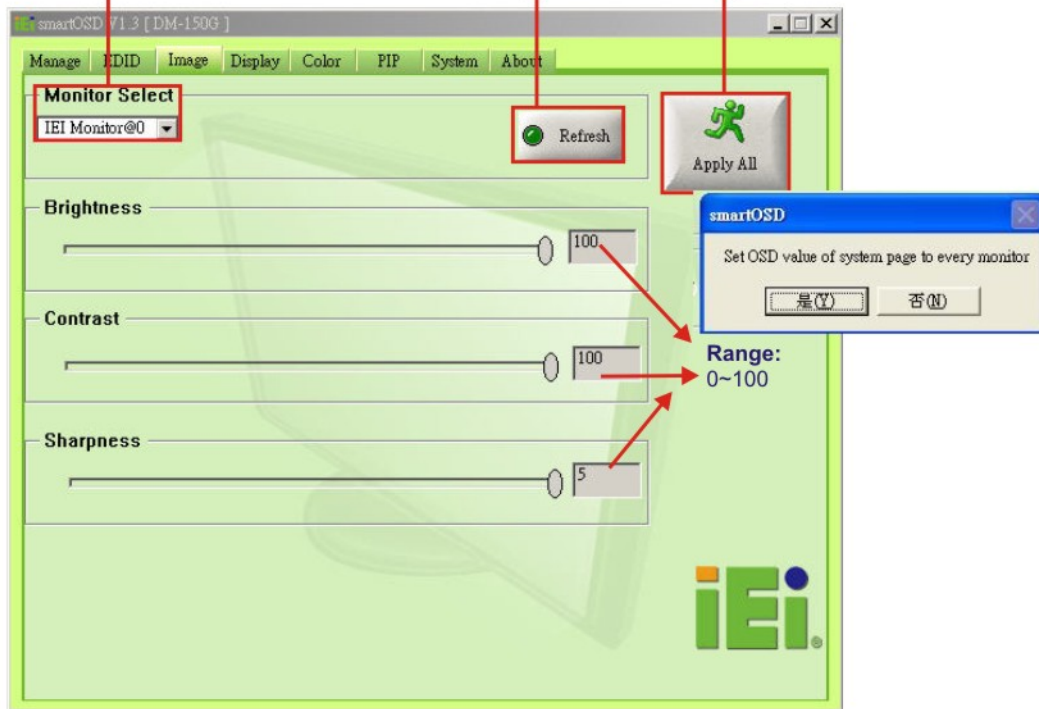

Figure C-10: Image Page

C.4.4 Display Page (for analog signal)

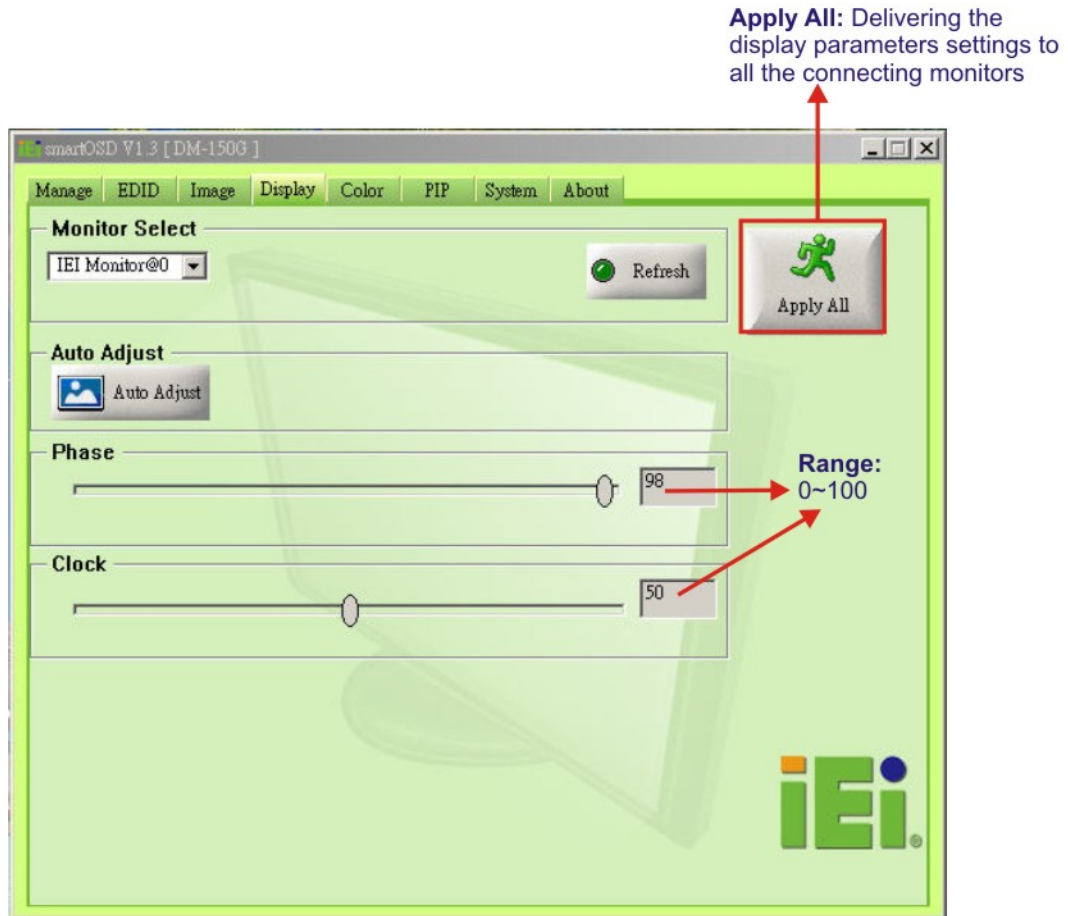

Figure C-11: Display Page

C.4.5 Color Page

Monitor Select: Selects the monitor unit for which the image parameters will be adjusted

Refresh: To update image information which has been affected by the color OSD settings

Apply All: Delivering the color parameters settings to all the connecting monitors

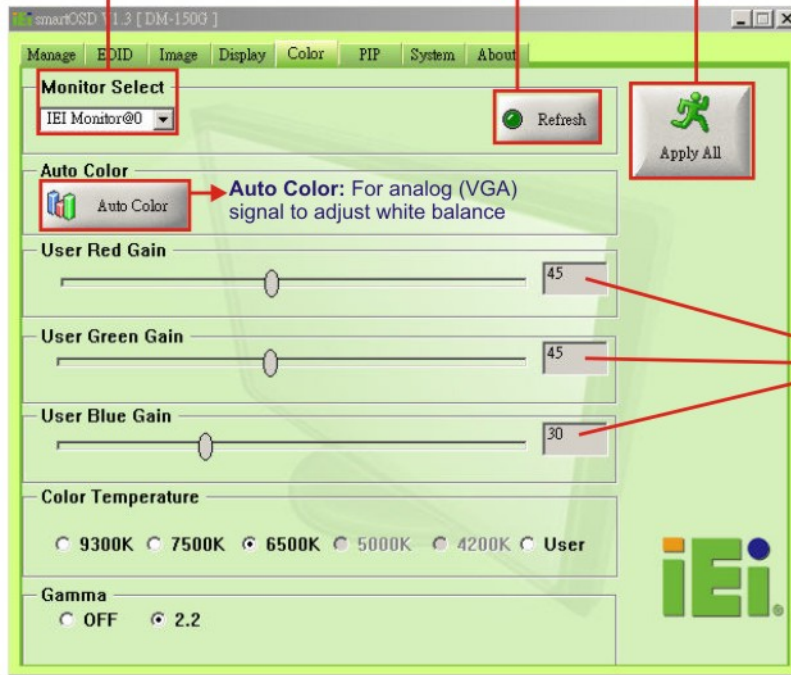

Auto Color: For analog (VGA) signal to adjust white balance

Range: 0~100 (Values can only be adjusted if user is selected for the Color Temperature)

Figure C-12: Color Page

C.4.6 PIP Page



NOTE:

The functions in the PIP page are only available in the MLCSD-KIT Series and AFOLUX Series monitors.



Figure C-13: PIP Page

C.4.7 System Page

Monitor Select: Selects the monitor unit for which the system parameters will be adjusted

Monitor Power Control: Press ALT+P buttons to boot the monitor again

Apply All: Delivering the system parameter settings to all the connecting monitors

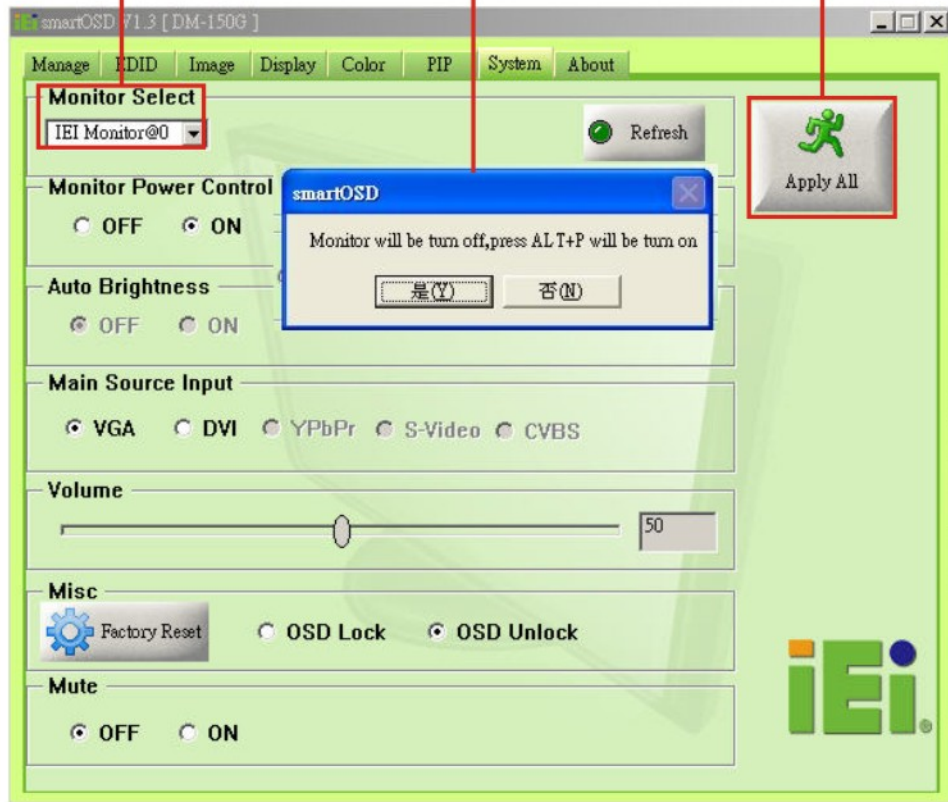

Figure C-14: System Page

**NOTE:**

Some of the functions in the System Page are only available to some of the IEI LCD series as following:

- Auto Brightness: SRM, MLCD-KIT and AFOLUX series only
- Main Source Input: MLCD-KIT and AFOLUX series only
- Volume: AFOLUX series only
- Mute: AFOLUX series only

C.4.8 About Page



Figure C-15: About Page

C.5 smartOSD FAQ

For troubleshooting, please see the steps below:

C.5.1 Windows 2000 Installation Failure

Installation fails under Windows 2000 and shows the following image:

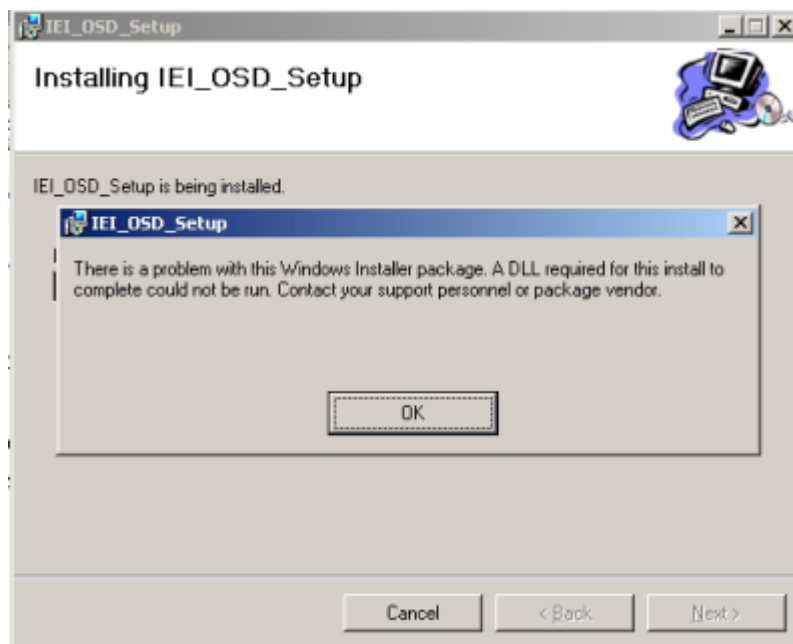

Figure C-16: DLL Missing

Solution: Download and install service pack Windows Installer 3.1

C.5.2 Vista Installation Failure

Installation fails under Vista while showing following image:



Figure C-17: Windows Vista Error

Solution: Install SmartOSD.exe with administrator authority

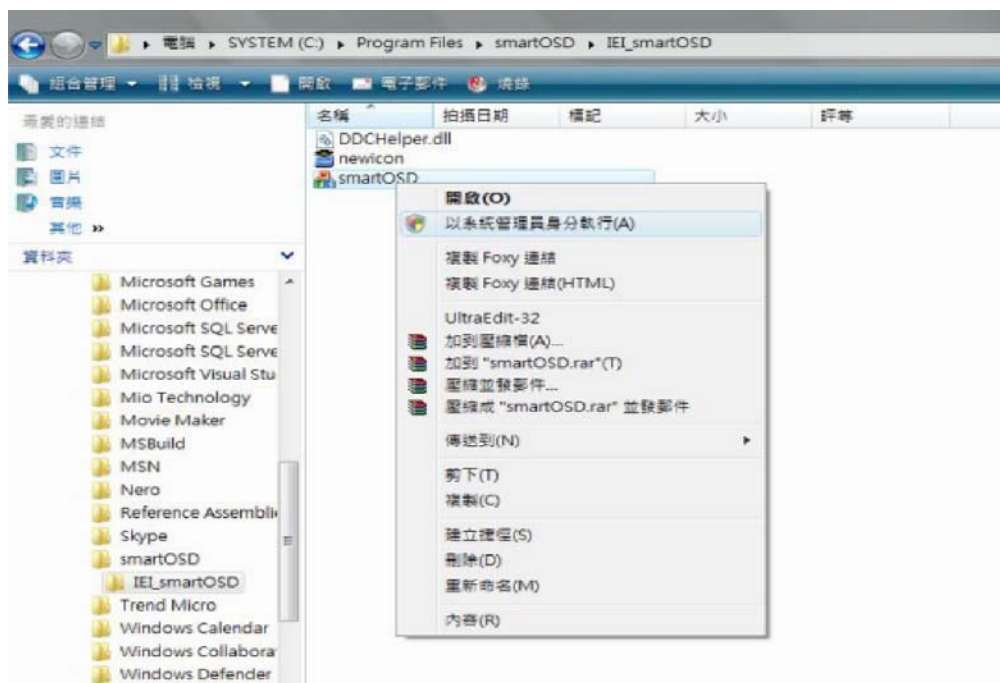

Figure C-18: Install as Administrator

C.5.3 Model Failure

The Model Fail error message shown below appears.



Figure C-19: Firmware Incompatibility

Solution: SmartOSD only supports firmware version 2.0 and following versions.

C.5.4 DCC Port Failure

The DDC port fail error message shown below appears.



Figure C-20: DCC Port Failure

Solutions:

- Check VGA or DVI cable
- Check an IEI monitor is being used
- Make sure the version is version 2.3 for the AFOLUX/MLCD-KIT series and version 1.5 for the LCD-KIT/ISLCD-KIT/TLCD-KIT/SRM/LCD-KIT series that have the SmartOSD functions
- Check if the OSD control status is busy. A busy signal may cause the signal message for a short time.