

Wide 10.2" WSVGA AFOLUX PPC

**AFL-W10A-N270**

Intel® Atom™ Processor N270 1.60 GHz



**New Wide Screen**

**Features**

- Wide 10.2" TFT LCD with resistive touch screen
- Fanless cooling system
- Built-in 2-megapixel camera with digital microphone module
- Selectable AT/ATX power mode through the switch inside the chassis
- System memory up to 2 GB SDRAM
- Built-in 802.11b/g/n wireless LAN
- Built-in two 1.5 W speakers
- One CompactFlash® slot
- IP 64 compliant front panel
- IEI One Key Recovery solution allows you to create rapid OS backup and recovery (Suggest over 4GB storage capacity)



**Specifications**

Model	AFL-W10A-N270
LCD Size	Wide 10.2"
Max Resolution	1024 x 600
Brightness (cd/m <sup>2</sup> )	400
Contrast Ratio	400: 1
LCD Color	262K
Pixel Pitch (mm)	0.2175 mm (H) x 0.2175 mm (V)
Viewing Angle (H-V)	140° / 120°
Backlight MTBF	40000 hrs
SBC Model	AFLMB-945GSE-N270-R10
CPU	Intel® Atom™ processor N270 1.6GHz CPU
Chipset	Intel® 945GSE + ICH7M
RAM	Supports one 400 MHz or 533MHz DDR2 SO-DIMM (Max. 2GB)
I/O Ports	1 x RS-232 COM Port 1 x RS-232/422/485 COM Port 2 x RJ-45 for GbE 2 x USB 2.0 1 x Power Switch 1 x Reset Button 1 x External SATA 1 x Audio Port 1 x Power Jack
Storage	CF Type II
Watchdog Timer	Software programmable supports 1~255 sec. system reset
Audio	AMP 1.5W + 1.5W (internal speakers)
Camera Module	2-megapixel with digital microphone
Wireless Connection	1 x Wireless LAN 802.11b/g/n Module (internal PCIe Mini card interface)
Construction Front Panel	ABS + PC Plastic front frame
LED Function	1 x Power on/off LED on front panel
Mounting	Panel, Wall, Rack, Stand and Arm VESA 100mm x 100mm
Front Panel Color	Gray 7539U
Dimensions (WxHxD) (mm)	280 x 186 x 49
Operation Temperature (°C)	-10°C ~50°C
Storage Temperature (°C)	-20°C ~ 60°C
N/G Weight	1.4 Kg
IP Level	IP 64 compliant front panel
Safety & EMC	CE / FCC
Touch Screen	5-wire resistive type (touch controller IC is on board)
Power Adapter	P/N: 63000-FSP036RAB608-RS 36W Power Adapter (Meet PSE) Input: 90VAC~264VAC, 50/60Hz Output: 12VDC
Power Requirement	12VDC
Power Consumption	28W

1 IEI Mobile Solutions  
2 Automation Panel Solutions  
3 PACSmate Medical Solutions  
4 Optional Peripherals

## Fully Integrated I/O

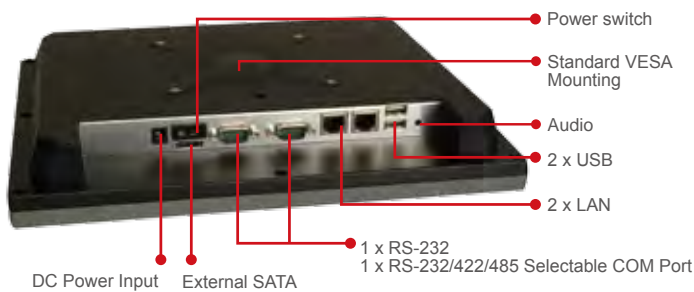

## Building Automation/Access Control System

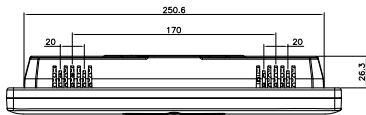

### AFL-W10A Dimensions (Unit: mm)

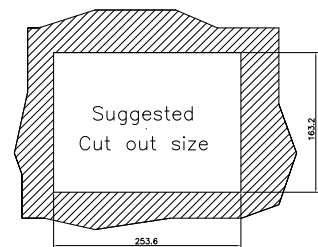
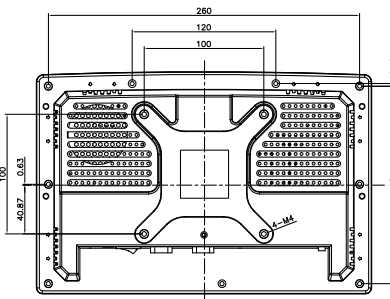
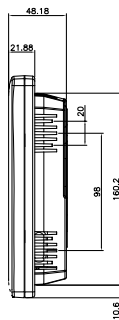
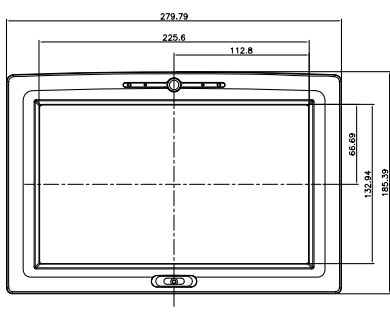

## Ordering Information

Part Number	Description
AFL-W10A-N270/R/1G-R32	10.2" 400 cd/m <sup>2</sup> , WSVGA fanless panel PC with Intel® Atom™ N270 1.6GHz, 802.11b/g/n wireless module, touch screen, 2megapixel camera with digital microphone, 1GB DDR2 533, R32

## Options

Model	AFL-W10A-N270
Panel Mounting Kit	AFLPK-12
Wall Mounting Kit	AFLWK-19B
Rack Mounting Kit	AFLRK-W10
Arm	ARM-11-RS / ARM-31-RS
Stand	STAND-A12-RS / STAND-100-RS
VSTAND	VSTAND-A10-R11
9-30VDC to 12VDC Converter Module	IDD-930160-KIT
OS	Win CE 6.0 (128 MB CF card)
	Win XPE (1 GB CF card)
	Win 7 Embedded (4GB CF card)
Magnetic Stripe Reader	AFLP-10AMSR-U
DC 12V Input UPS	AUPS-B10-R10 (7.4V 3800mAh)
DC 9-36V Input UPS	AUPS-B20-R10 (7.4V 3800mAh)
Bluetooth V2.0+EDR	AFL-BT-KIT02-R10

## ISMM Supported Functions

	Voltage	Fan	Smart Fan	Temperature	DIO	WDT	Beep	Cash Drawer
AFL-W10A-N270	V			V		V		

## Packing List

Item	Part Number	Q'ty	Specification
Screw Pack	44013-030041-RS	4	M3; 5mm
Power Adpater	63000-FSP036RAB608-RS	1	90~264V AC; 12V DC; 36W (Meet PSE)
Power Cord	32000-000002-RS	1	1750mm; European Standard (EU or US, depending on the shipment country)
Utility CD	7B000-000087-RS	1	
Touch Pen	43125-0002C0-00-RS	1	
One Key Recovery CD		1	

Note: Win CE application without digital microphone function