

KM-088G
88 key and Touch Pad Module
USER'S MANUAL
Ver 1.1

KM-088G is 88 Keys and Touch Pad Module. Standard support of English version keyboard and optional Japanese, German, French, Italian, Chinese ,Russian version keyboard support.

Notes:

KM-088G-L

L: Language Code **EN: English, JP: Japanese, DE: German,**
 FR: French, IT: Italian, CH: Chinese.
 RU:Russian

KM-088G-EN English version keyboard

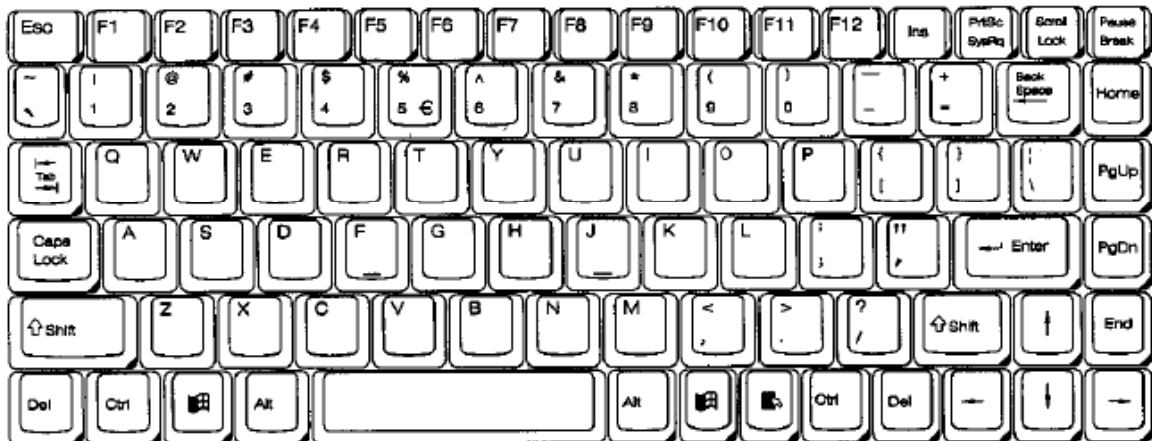

KM-088G- JP Japanese version keyboard

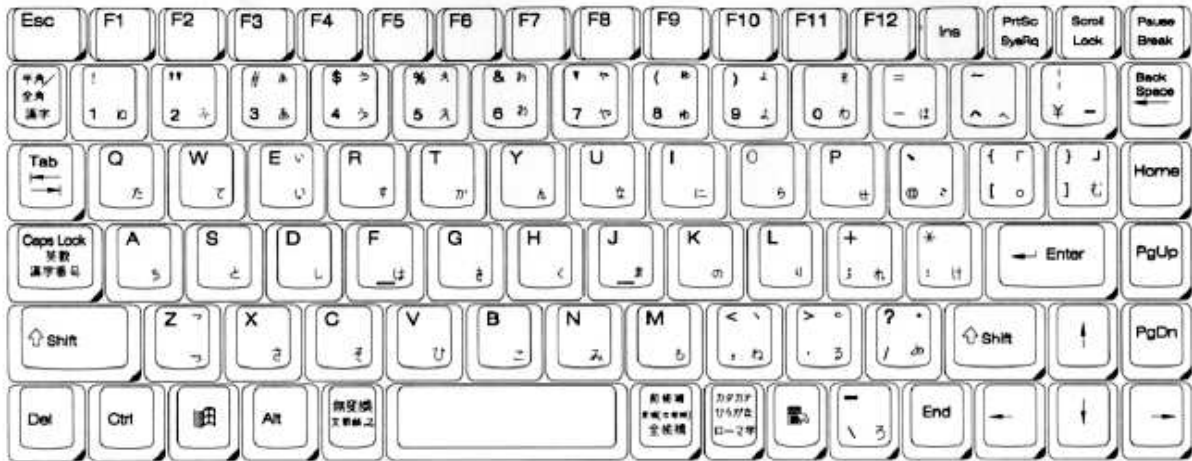

KM-088G- DE German version keyboard



KM-088G- **FR** French version keyboard



KM-088G- **IT** Italian version keyboard



KM-088G- **CH** Chinese version keyboard



KM-088G- **RU** Russian version keyboard

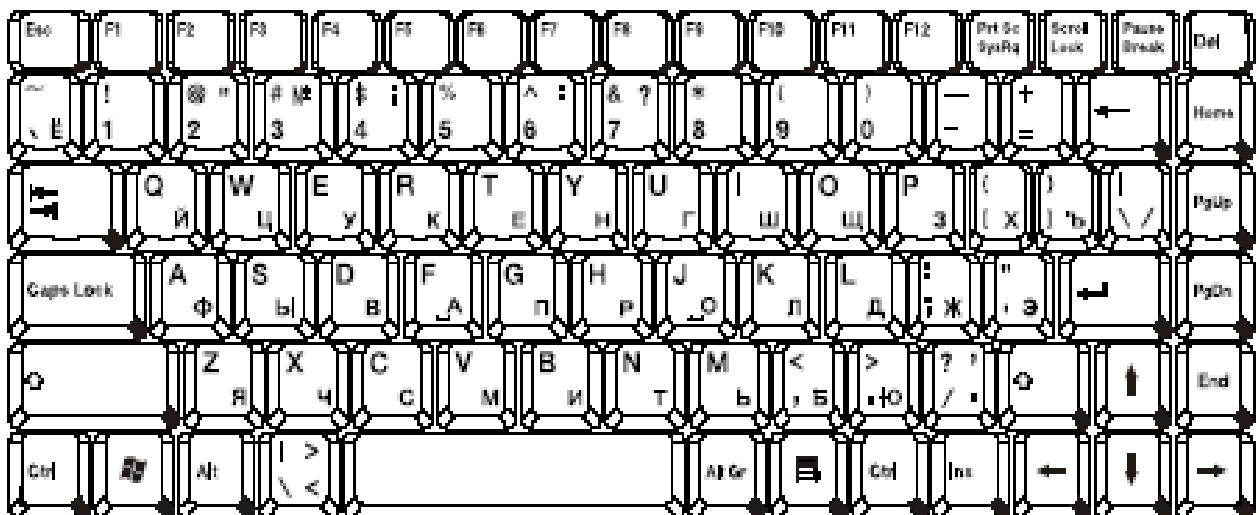

● Dimensions

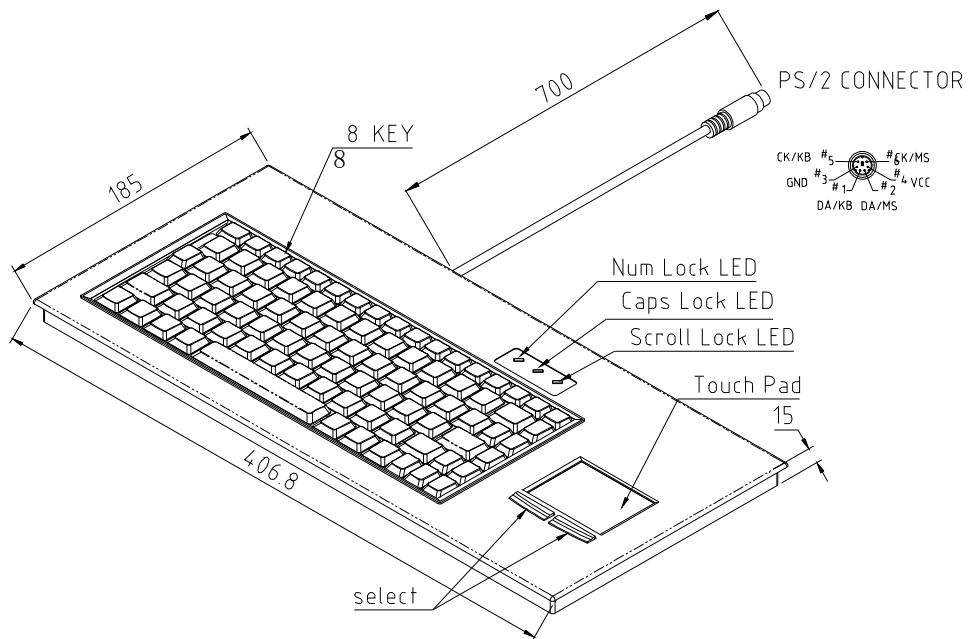

● Accessory Kit

1. Screws set --- 1 set.
2. User's manual---1 set.

Use 4 sink screws (6#32*6) to fix KM-088 in EC-1040 chassis, please.

