

Quick Installation Guide

SPL-101GT Series

Industrial Gigabit Splitter

Introduction

SPL-101GT series is a high power PoE Splitter for use in Power over Ethernet systems. With Ethernet Input (data + power) port and Output (data only) port, SPL-101GT series may split power from existing LAN cable and convert up to 24VDC/1.125A or 12VDC/1.6A(SPL-101GT-12V) for power hungry applications such as Wireless APs, Security cameras and IP Phones. The internal current limit, short-circuit and overload protection are implemented for use as a DC power supply.

Features

- > Fully compliant with IEEE802.3at standard
- > Supports 10/100/1000Base-T(X) for PoE In and Data Out
- > Power Isolation and Short Circuit Protection for Power Output
- > Auto protection for Over Voltage Power Input
- > Supports Power Outputs up to 27Watts
- > IP-30 Rugged Case Design
- > DIN-Rail and wall-mount enabled

Connections

Connections of Splitter

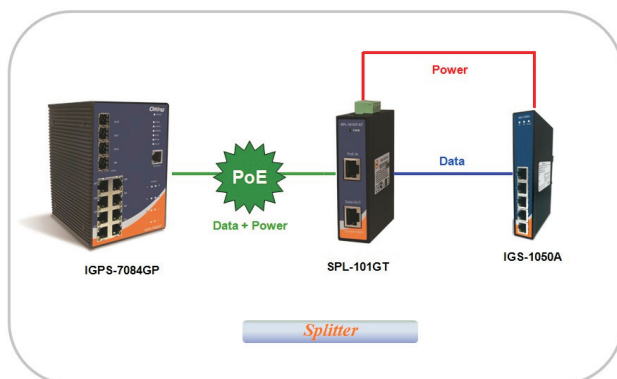

Power Connection Guide

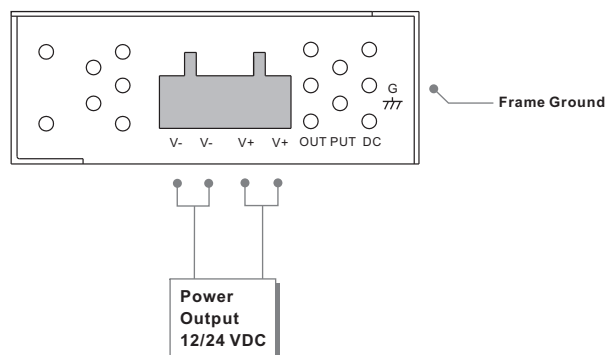

Specifications

ORing PoE Splitter Model	SPL-101GT	SPL-101GT-12V
Physical Ports		
10/100/1000 Base-T(X) Ports in RJ45 Auto MDI/MDIX	1	
10/100/1000Base-T(X) P.D. Port in RJ45 Auto MDI/MDIX	1	
Operating Voltage		
Input Voltage	36 ~ 57 VDC on RJ45 connector	
Output Power	24Vdc @ 1.125A max. (27 Watts)	12Vdc @ 1.6A max. (20 Watts)
LED indicators		
Power indicator	PWR / Ready: 1 x LED	
	Blue On: Power is on and functioning Normally.	Green On: Power is on and functioning Normally.
Protection		
Short Circuit Protection	Present	
Over Load Protection	Present	
Isolation Protection	1500V	
Physical Characteristic		
Enclosure	IP-30	
Dimension (W x D x H)	26.1(W) x 70(D) x 95(H)mm (1.03x 2.76 x 3.74inch.)	
Weight (g)	250 g	250 g
Environmental		
Storage Temperature	-40 to 85°C (-40 to 185°F)	
Operating Temperature	-40 to 70°C (-40 to 158°F)	
Operating Humidity	5% to 90% Non-condensing	
Regulatory Approvals		
EMI	FCC Part 15, CISPR (EN55022) class A	
EMS	EN61000-4-2 (ESD), EN61000-4-3 (RS), EN61000-4-4 (EFT), EN61000-4-5 (Surge), EN61000-4-6 (CS), EN61000-4-8, EN61000-4-11	
Safety	EN60950-1	
Warranty	5 years	

Connector and Pin Definition

PoE Definition 1

1000Base-T

		RJ-45 Input (Data and Power)		RJ-45 Output (Data Only)	
	Symbol	Description	Symbol	Description	
1	BI_DA+	Data BI_DA+	BI_DA+	Data BI_DA+	
2	BI_DA-	Data BI_DA-	BI_DA-	Data BI_DA-	
3	BI_DB+	Data BI_DB+	BI_DB+	Data BI_DB+	
4	BI_DC+ (Vdc+)	Data BI_DC+ and Feeding power(+)	BI_DC+	Data BI_DC+	
5	BI_DC- (Vdc-)	Data BI_DC- and Feeding power(+)	BI_DC-	Data BI_DC-	
6	BI_DB-	Data BI_DB-	BI_DB-	Data BI_DB-	
7	BI_DD+ (Vdc-)	Data BI_DD+ and Feeding power(-)	BI_DD+	Data BI_DD+	
8	BI_DD- (Vdc-)	Data BI_DD- and Feeding power(-)	BI_DD-	Data BI_DD-	

10/100 Base-T(X)

		RJ-45 Input (Data and Power)		RJ-45 Output (Data Only)	
	Symbol	Description	Symbol	Description	
1	Rx+	Data Receive	Rx+	Data Receive	
2	Rx-	Data Receive	Rx-	Data Receive	
3	Tx+	Data Transmit	Tx+	Data Transmit	
4	Vdc+	Feeding power(+)	NC	Not Connected	
5	Vdc-	Feeding power(+)	NC	Not Connected	
6	Tx-	Data Transmit	Tx-	Data Transmit	
7	Vdc-	Feeding power(-)	NC	Not Connected	
8	Vdc-	Feeding power(-)	NC	Not Connected	

Note: pins 7 and 8 (-Vdc) should not be shorted to ground

PoE Definition 2

1000Base-T

		RJ-45 Input (Data and Power)		RJ-45 Output (Data Only)	
	Symbol	Description	Symbol	Description	
1	BI_DA+ (Vdc+)	Data BI_DA+ and Feeding power(+)	BI_DA+	Data BI_DA+	
2	BI_DA- (Vdc-)	Data BI_DA- and Feeding power(+)	BI_DA-	Data BI_DA-	
3	BI_DB+ (Vdc-)	Data BI_DB+ and Feeding power(-)	BI_DB+	Data BI_DB+	
4	BI_DC+	Data BI_DC+	BI_DC+	Data BI_DC+	
5	BI_DC-	Data BI_DC-	BI_DC-	Data BI_DC-	
6	BI_DB- (Vdc-)	Data BI_DB- and Feeding power(-)	BI_DB-	Data BI_DB-	
7	BI_DD+	Data BI_DD+	BI_DD+	Data BI_DD+	
8	BI_DD-	Data BI_DD-	BI_DD-	Data BI_DD-	

10/100 Base-T(X)

		RJ-45 Input (Data and Power)		RJ-45 Output (Data Only)	
	Symbol	Description	Symbol	Description	
1	Rx+ (Vdc+)	Data Receive and Feeding power(+)	Rx+	Data Receive	
2	Rx- (Vdc+)	Data Receive and Feeding power(+)	Rx-	Data Receive	
3	Tx+ (Vdc-)	Data Transmit and Feeding power(-)	Tx+	Data Transmit	
4	NC	Not Connected	NC	Not Connected	
5	NC	Not Connected	NC	Not Connected	
6	Tx- (Vdc-)	Data Transmit and Feeding power(-)	Tx-	Data Transmit	
7	NC	Not Connected	NC	Not Connected	
8	NC	Not Connected	NC	Not Connected	

Note: pins 3 and 6 (-Vdc) should not be shorted to ground



Quick Installation Guide

SPL-101GT Series

Industrial Gigabit Splitter

Installation

Din-Rail Install Step

Wall-mounted Install Step

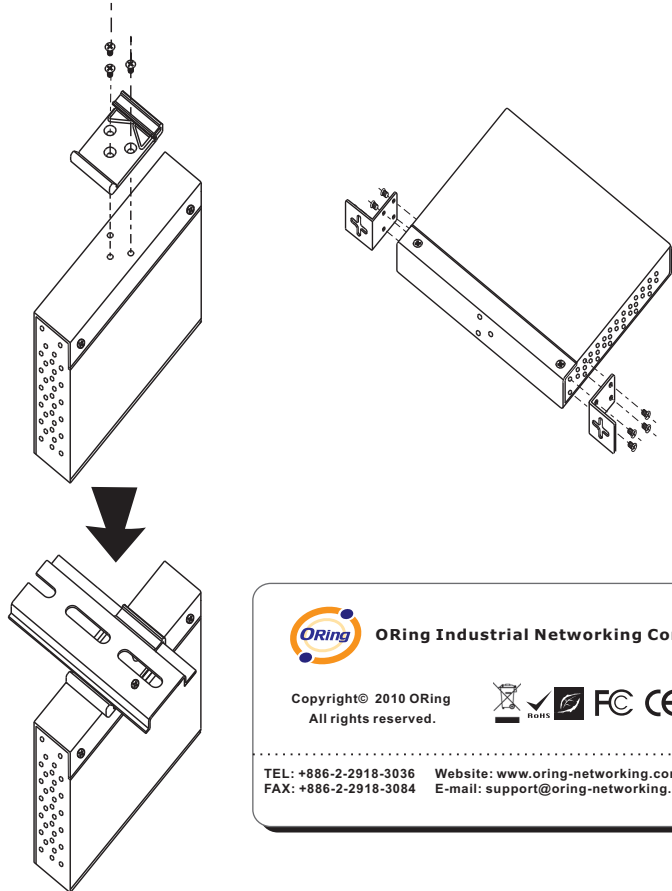

ORing ORing Industrial Networking Corp.
 Copyright© 2010 ORing All rights reserved.
 TEL: +886-2-2918-3036 Website: www.oring-networking.com
 FAX: +886-2-2918-3084 E-mail: support@oring-networking.com

Front Panel

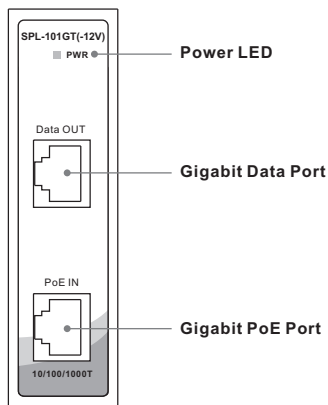

Accessory

- ① 4-Pin Terminal block
- ② Dust Cover (RJ-45)
- ③ Screw (M3 X3)



④ Wall-mounted kit



⑤ 25mm DIN-Rail kit

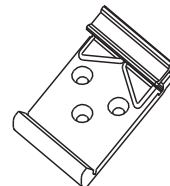

⑥ QIG

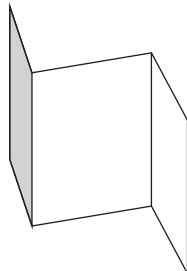

Communication Connections

100Base-T Ethernet Port Connection

RJ45 (8-pin, MDI) Port Pinouts

Pin	MDI
1	BI_DA+
2	BI_DA-
3	BI_DB+
4	BI_DC+
5	BI_DC-
6	BI_DD-
7	BI_DD+
8	BI_DC-

RJ45 (8-pin, MDI-X) Port Pinouts

Pin	MDI-X
1	BI_DB+
2	BI_DB-
3	BI_DA+
4	BI_DD+
5	BI_DD-
6	BI_DA-
7	BI_DC+
8	BI_DC-

10/100Base-T(X) Ethernet Port Connection

RJ45 (8-pin, MDI) Port Pinouts

Pin	Single
1	Tx+
2	Tx-
3	Rx+
6	Rx-

RJ45 (8-pin, MDI-X) Port Pinouts

Pin	Single
1	Rx+
2	Rx-
3	Tx+
6	Tx-

RJ45 (8-pin) to RJ45 (8-Pin) Straight-Through Cable Wiring

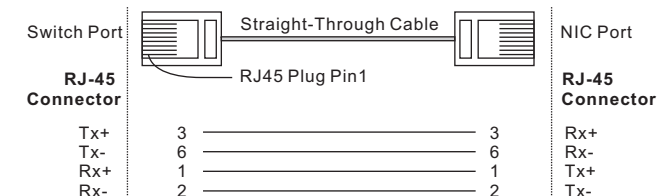

RJ45 (8-pin) to RJ45 (8-Pin) Cross-Over Cable Wiring

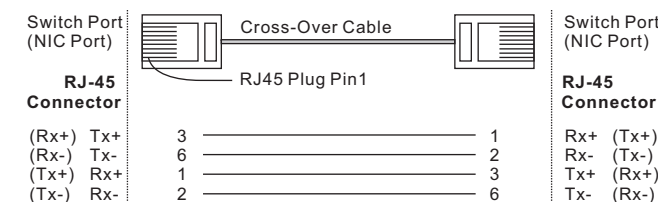

Packing list

Model name	Model Description	Accessory
SPL-101GT	Industrial 1-port Gigabit High Power PoE Splitter, IEEE 802.3at standard compliant	⊙X1, ⊙X2, ⊙X8, ⊙X2, ⊙X1, ⊙X1
SPL-101GT-12V	Industrial 1-port Gigabit High Power PoE Splitter, IEEE 802.3at standard compliant, 12VDC output	⊙X1, ⊙X2, ⊙X8, ⊙X2, ⊙X1, ⊙X1