

MODEL:

IDDUPS-6364120A/636260A

**120W/60W DC/DC Converter Module
with UPS and Utility Software**

User Manual

Revision

| Date | Version | Changes |
|-----------------|---------|---|
| May 7, 2014 | 1.21 | Added Appendix A: Safety Precautions |
| January 7, 2010 | 1.20 | Added CN8 connector information (Section 4.2.6) |
| August 2007 | 1.01 | - Added Chapter 5: Software - Added RS-232 cable connector (JP2) pinouts |
| May 2007 | 1.00 | Initial release |

Copyright

COPYRIGHT NOTICE

The information in this document is subject to change without prior notice in order to improve reliability, design and function and does not represent a commitment on the part of the manufacturer.

In no event will the manufacturer be liable for direct, indirect, special, incidental, or consequential damages arising out of the use or inability to use the product or documentation, even if advised of the possibility of such damages.

This document contains proprietary information protected by copyright. All rights are reserved. No part of this manual may be reproduced by any mechanical, electronic, or other means in any form without prior written permission of the manufacturer.

TRADEMARKS

All registered trademarks and product names mentioned herein are used for identification purposes only and may be trademarks and/or registered trademarks of their respective owners.

Packing List

**NOTE:**

If any of the components listed in the checklist below are missing, please do not proceed with the installation. Contact the IEI reseller or vendor you purchased the IDDUPS-6364120/636260 from or contact an IEI sales representative directly. To contact an IEI sales representative, please send an email to sales@ieiworld.com.tw.

The items listed below should all be included in the IDDUPS-6364120/636260 package.

- 1 x IDDUPS-6364120/636260 DC/DC converter module
- 1 x RS-232 cable
- 1 x Utility software CD
- 1 x QIG (Quick Installation Guide)

Optional items:

- Li-Polymer Smart Battery
- Cable for AC-DC adapters
- Cable for 63000-FSP120AAB-RS 120W AC-DC adapter
- Cable for Terminal Block
- Output power cable for SATA
- Output power cable for IDE or any standard 4-pin I/O devices
- 20p-20p ATX cable (for IDDUPS-6364120A)
- SBC main power cable (for IDDUPS-636260A)
- Cable with on/off switch
- Cable to SBC (5VSB & PS_ON)

Images of the above items are shown in **Chapter 3**.

Table of Contents

| | |
|---|-----------|
| 1 INTRODUCTION..... | 9 |
| 1.1 IDDUPS-6364120/636260 OVERVIEW | 10 |
| 1.2 IDDUPS-6364120/636260 POWER MODULE FEATURES..... | 10 |
| 1.3 IDDUPS-6364120/636260 DIMENSIONS | 11 |
| 2 DETAILED SPECIFICATIONS | 12 |
| 2.1 IDDUPS-6364120/636260 SYSTEM BLOCK DIAGRAM..... | 13 |
| 2.2 SAFETY | 14 |
| 2.3 BATTERY SPECIFICATIONS | 14 |
| 3 UNPACKING | 16 |
| 3.1 ANTI-STATIC PRECAUTIONS | 17 |
| 3.2 UNPACKING..... | 17 |
| 3.2.1 <i>Unpacking Precautions</i> | 17 |
| 3.3 UNPACKING CHECKLIST | 18 |
| 3.3.1 <i>Package Contents</i> | 18 |
| 3.3.2 <i>Optional Items</i> | 19 |
| 4 CONNECTOR PINOUTS..... | 21 |
| 4.1 PERIPHERAL INTERFACE CONNECTORS..... | 22 |
| 4.1.1 <i>IDDUPS-6364120 Layout</i> | 22 |
| 4.1.2 <i>IDDUPS-636260 Layout</i> | 22 |
| 4.1.3 <i>Peripheral Interface Connectors</i> | 23 |
| 4.1.4 <i>Jumper</i> | 23 |
| 4.2 INTERNAL PERIPHERAL CONNECTORS | 24 |
| 4.2.1 <i>ATX Mode Connector</i> | 24 |
| 4.2.2 <i>ATX Power Connector (IDDUPS-6364120A Only)</i> | 25 |
| 4.2.3 <i>Battery Connectors</i> | 26 |
| 4.2.4 <i>Input Power Connector</i> | 27 |
| 4.2.5 <i>Output Power Connectors</i> | 29 |
| 4.2.6 <i>Power Switch Connector</i> | 30 |

| | |
|--|-----------|
| 4.2.7 RS-232 Cable Connector | 31 |
| 4.2.8 SBC Main Power Connector (IDDUPS-636260A Only)..... | 32 |
| 4.3 JUMPER SETTINGS | 33 |
| 4.3.1 AT/ATX Mode Select Jumper | 33 |
| 5 SOFTWARE APPLICATION..... | 35 |
| 5.1 INTRODUCTION..... | 36 |
| 5.2 MONITORING DC POWER AND SMART BATTERY | 36 |
| 5.2.1 Using the Application..... | 36 |
| 5.2.2 Status Information..... | 36 |
| 5.2.2.1 DC Detection | 37 |
| 5.2.2.2 Battery Detection | 37 |
| 5.2.2.3 Battery Remaining Time..... | 38 |
| 5.2.3 Battery Information..... | 39 |
| 5.2.4 Setting | 39 |
| 5.3 SYSTEM LOG | 41 |
| 5.4 EXIT | 42 |
| A SAFETY PRECAUTIONS | 43 |
| B HAZARDOUS MATERIALS DISCLOSURE | 49 |
| B.1 HAZARDOUS MATERIAL DISCLOSURE TABLE FOR IPB PRODUCTS CERTIFIED AS ROHS COMPLIANT UNDER 2002/95/EC WITHOUT MERCURY | 50 |

List of Figures

| | |
|--|----|
| Figure 1-1: IDDUPS-6364120/636260 Dimensions (mm)..... | 11 |
| Figure 2-1: IDDUPS-6364120/636260 System Block Diagram | 13 |
| Figure 4-1: IDDUPS-6364120 Connector and Jumper Locations..... | 22 |
| Figure 4-2: IDDUPS-636260 Connector and Jumper Locations..... | 22 |
| Figure 4-3: ATX Mode Connector Location | 24 |
| Figure 4-4: ATX Power Connector Location | 25 |
| Figure 4-5: Battery Connector Locations..... | 27 |
| Figure 4-6: Battery Connected | 27 |
| Figure 4-7: Input Power Connector Location | 28 |
| Figure 4-8: Output Power Connector Locations | 29 |
| Figure 4-9: Power Switch Connector Locations..... | 30 |
| Figure 4-10: RS-232 Cable Connector Location | 31 |
| Figure 4-11: JP2 Connector Cable (RS-232 cable)..... | 32 |
| Figure 4-12: SBC Main Power Connector Location | 32 |
| Figure 4-13: CN7 Connector Cables | 33 |
| Figure 4-14: AT/ATX Mode Select Jumper Location..... | 34 |
| Figure 5-1: IDDUPS Battery Status Monitor Application | 36 |
| Figure 5-2: Status Information | 37 |
| Figure 5-3: DC Detection..... | 37 |
| Figure 5-4: Battery Detection | 38 |
| Figure 5-5: Battery Remaining Time | 38 |
| Figure 5-6: Battery Information | 39 |
| Figure 5-7: Application Setting | 40 |
| Figure 5-8: COM Port Status..... | 40 |
| Figure 5-9: Special Event Pop-up Setting | 40 |
| Figure 5-10: IDDUPS Application Quick Launch Icon..... | 41 |
| Figure 5-11: System Log Example | 41 |
| Figure 5-12: Exit IDDUPS Application | 42 |

List of Tables

| | |
|--|----|
| Table 1-1: Output Voltage | 11 |
| Table 2-1: BAT-LI-2S1P3000 Specifications | 15 |
| Table 3-1: Package List Contents | 18 |
| Table 3-2: Optional Items | 20 |
| Table 4-1: Peripheral Interface Connectors | 23 |
| Table 4-2: Rear Panel Connectors | 23 |
| Table 4-3: ATX Mode Connector Pinouts | 24 |
| Table 4-4: CN2 Connector Cables | 25 |
| Table 4-5: ATX Power Connector Pinouts | 26 |
| Table 4-6: J3 Connector Cables | 26 |
| Table 4-7: Battery Connector Pinouts | 27 |
| Table 4-8: Input Power Connector Pinouts | 28 |
| Table 4-9: CN1 Connector Cables | 29 |
| Table 4-10: Output Power Connector Pinouts | 29 |
| Table 4-11: CN3 & CN4 Connector Cables | 30 |
| Table 4-12: Power Switch Connector Pinouts | 31 |
| Table 4-13: RS-232 Cable Connector Pinouts | 31 |
| Table 4-14: SBC Main Power Connector Pinouts | 32 |
| Table 4-15: AT/ATX Mode Select Jumper Settings | 34 |

Chapter

1

Introduction

1.1 IDDUPS-6364120/636260 Overview

The highly efficient, high-performance IDDUPS-6364120/636260 DC-to-DC converter module provides 5V, 3.3V, 12V, -12V and 5VSB outputs. The IDDUPS-6364120/636260 supports up to two Li-Polymer smart batteries to provide stable and uninterruptible power. The power module also receives a wide range of inputs between 6 and 36 VDC. The IDDUPS-6364120/636260 is built on an intelligent design and provides outstanding line and load regulations. The IDDUPS-6364120/636260 is capable of sustaining 90% power efficiency.

The IDDUPS-6364120/636260 power module also comes with the utility software that provides information on current power source, battery status, charging status and remaining percentage.

1.2 IDDUPS-6364120/636260 Power Module Features

- Highly compact design
- High efficiency up to 90%
- Load down protection
- Over voltage protection
- Over current protection
- Short circuit protection
- Supports up to two battery packs
- Supports AT or ATX mode
- RoHS compliant
- I/O interface:
 - SMBus/I²C
 - RS-232
- Utility software: pull data out through RS-232 to system
- Total output capacity:
 - IDDUPS-6364120A: 120W
 - IDDUPS-636260A: 60W
- Input Voltage: 6VDC to 36VDC

IDDUPS Series DC/DC Converter Module

- Output Voltage:

| Voltage (Max Load) | +5V | +12V | -12V | +3.3V | 5VSB |
|--------------------|-----|------|------|-------|------|
| IDDUPS-6364120A | 10A | 4A | 0.3A | 8A | 2A |
| IDDUPS-636260A | 10A | 3A | - | - | 0.5A |

Table 1-1: Output Voltage

- Dimensions: 60mm x 160mm
- Environment:
 - Operating temperature: -20°C ~ +85°C
 - Storage temperature: -40°C ~ +125°C
- Weight: NW:
 - IDDUPS-6364120A: 98g
 - IDDUPS-636260A: 75g

1.3 IDDUPS-6364120/636260 Dimensions

Figure 1-1 shows the IDDUPS-6364120/636260 dimensions. The dimensions are given in millimeters.

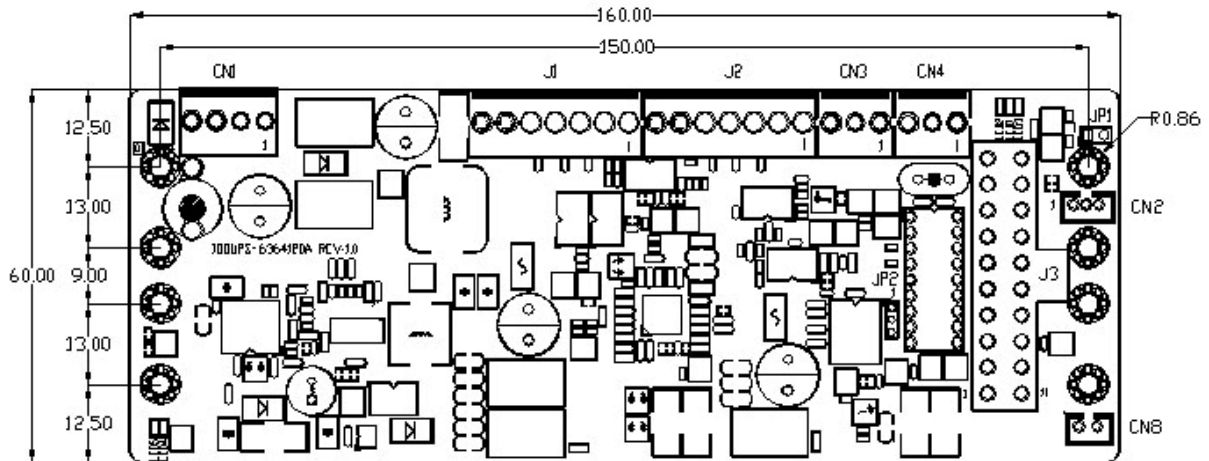

Figure 1-1: IDDUPS-6364120/636260 Dimensions (mm)

Chapter

2

Detailed Specifications

IDDUPS Series DC/DC Converter Module

2.1 IDDUPS-6364120/636260 System Block Diagram

Figure 2-1 shows the system block diagram of the IDDUPS-6364120/636260. The detailed descriptions of the system operation are described in the following sections.

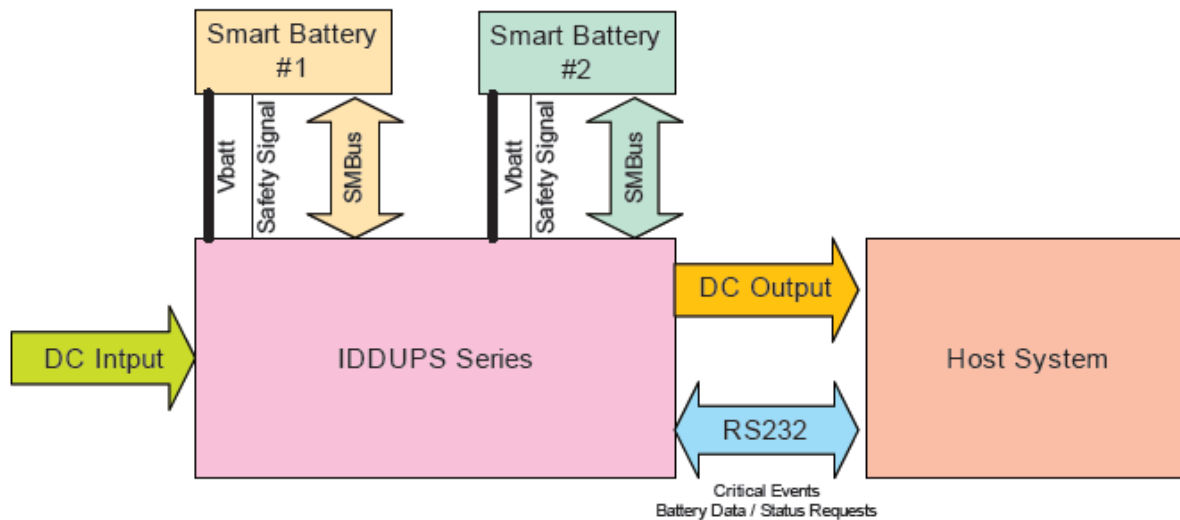

Figure 2-1: IDDUPS-6364120/636260 System Block Diagram

The IDDUPS series is a charging circuit that provides the Smart Battery with charging current and charging voltage from DC input to match the requirements from Smart Battery. The IDDUPS series also provides DC output power to the Host System with following features:

- Provide stable and uninterruptible power to equipment during a power outage, line sags and spikes
- Absorb power surges and transients
- Smooth out noisy power sources

The IDDUPS series receives critical events from the Smart Battery when it detects a problem. The Smart Battery communicates with IDDUPS series via two separate communication interfaces:

- The SMBus CLOCK and DATA lines (primary communication channel)
- The secondary signaling mechanism or Safety Signal (secondary communication channel)

The Host System (SMBus Host) requests information from the battery and then uses it to provide the user information about the battery present state and capabilities. The Host System (SMBus Host) also receives critical events from the Smart Battery when it detects a problem. Using the utility software, the battery state and capabilities can be shown in the Host System through RS-232.

2.2 Safety

Both the battery and the IDDUPS series must agree it is safe enough to begin charging. If the battery detects some error conditions, the charging never begins. The error conditions might include:

- battery pack voltage too high or low,
- temperature out of acceptable ranges,
- individual cell voltage shorted.

Furthermore, to continue charging, both the battery and the IDDUPS series must be satisfied it is still safe to do so. The battery sends a message or stop sending messages to the IDDUPS series to terminate charge if any error condition occurs in the battery. Second, the IDDUPS series monitors the battery pack Safety Signal terminal. If the Safety Signal moves out of a range that allows charging, the IDDUPS series immediately terminates charge. This could happen if the temperature of the battery pack got too hot.

These mechanisms are independent of and in addition to any protection mechanisms in the battery pack itself, for example, fuses or protection FETs controlled by hard-wired safety circuitry.

2.3 Battery Specifications

The IDDUPS series may also come with a Li-Polymer smart battery. Some of the Li-Polymer smart battery specifications are listed in **Table 2-1**.

| | |
|-------------------------|---|
| Battery Type | Li-Polymer |
| Nominal Capacity | 3000mAH |
| Nominal Voltage | 7.4V (Two 3.7V Li-Polymer battery cell) |

IDDUPS Series DC/DC Converter Module

| | |
|------------------------------|---|
| Main Board | Dual-cell Li-Ion battery PCB, Gauge IC and NTC 10K Ω |
| Max. Output Power | 100W |
| Max. Output Current | 16.7AH |
| Housing | DR202 |
| Dimensions | 148mm x 89mm x 20mm |
| Operating Temperature | -20°C ~ +60°C |
| Weight | 230g |

Table 2-1: BAT-LI-2S1P3000 Specifications

Chapter

3

Unpacking

3.1 Anti-static Precautions



WARNING:

Failure to take ESD precautions during the installation of the IDDUPS-6364120/636260 may result in permanent damage to the IDDUPS-6364120/636260 and severe injury to the user.

Electrostatic discharge (ESD) can cause serious damage to electronic components, including the IDDUPS-6364120/636260. Dry climates are especially susceptible to ESD. It is therefore critical that whenever the IDDUPS-6364120/636260, or any other electrical component is handled, the following anti-static precautions are strictly adhered to.

- **Wear an anti-static wristband:** Wearing a simple anti-static wristband can help to prevent ESD from damaging the board.
- **Self-grounding:** Before handling the board touch any grounded conducting material. During the time the board is handled, frequently touch any conducting materials that are connected to the ground.
- **Use an anti-static pad:** When configuring the IDDUPS-6364120/636260, place it on an anti-static pad. This reduces the possibility of ESD damaging the IDDUPS-6364120/636260.
- **Only handle the edges of the PCB:** When handling the PCB, hold the PCB by the edges.

3.2 Unpacking

3.2.1 Unpacking Precautions

When the IDDUPS-6364120/636260 is unpacked, please do the following:

- Follow the anti-static precautions outlined in **Section 3.1**.
- Make sure the packing box is facing upwards so the IDDUPS-6364120/636260 does not fall out of the box.
- Make sure all the components shown in **Section 3.3** are present.

3.3 Unpacking Checklist



NOTE:

If some of the components listed in the checklist below are missing, please do not proceed with the installation. Contact the IEI reseller or vendor you purchased the IDDUPS-6364120/636260 from or contact an IEI sales representative directly. To contact an IEI sales representative, please send an email to sales@ieiworld.com.tw.

3.3.1 Package Contents

The IDDUPS-6364120/636260 is shipped with the following components:





| Quantity | Item | Image |
|----------|--|---|
| 1 | IDDUPS-6364120A / IDDUPS-636260A DC/DC converter module |  |
| 1 | RS-232 cable (P/N: 32100-157200-RS) |  |
| 1 | Utility software CD |  |
| 1 | QIG (Quick Installation Guide) |  |

Table 3-1: Package List Contents

IDDUPS Series DC/DC Converter Module





3.3.2 Optional Items



NOTE:

The items listed in this section are optional items that must be ordered separately. Please contact your IDDUPS-6364120A/636260A vendor, distributor or reseller for more information or, contact iEi directly by sending an email to sales@ieiworld.com.tw.

The following optional items are available for the IDDUPS-6364120A/636260A.

| Quantity | Item and Part Number | Image |
|------------------------|---|---|
| 1 | Li-Polymer Smart Battery, 2S1P, 3000mAH (P/N: BAT-LI-2S1P3000) |  |
| DC Input Cable | | |
| 1 | Cable for following AC-DC adapters -FSP0601AD101C 60W -UP0451E12P 45W -UP0251E12PL 25W (P/N: CB-P1LP4-RS) |  |
| 1 | Cable for 63000-FSP120AAB-RS 120W AC-DC adapter (P/N: CB-MD4P4-RS) |  |
| 1 | Cable for Terminal Block (P/N: CB-NOLP4-RS) |  |
| I/O Power Cable | | |







| | | |
|-----------------------------|---|---|
| 1 | Output power cable for SATA (P/N : CB-3PSATA-RS) |  |
| 1 | Output power cable for IDE or any standard 4-pin I/O devices (P/N : CB-3PIDE-RS) |  |
| SBC Main Power Cable | | |
| 1 | 20p-20p ATX cable (for IDDUPS-6364120A) (P/N : CB-ATX20P-RS) |  |
| 1 | SBC main power cable (for IDDUPS-636260A) (P/N : CB-5PSBC-RS) |  |
| Power On/Off Cable | | |
| 1 | Cable with on/off switch (P/N : CB-JST3PSW-RS) |  |
| 1 | Cable to SBC (5VSB & PS_ON) (P/N : CB-JST3P001-RS) |  |

Table 3-2: Optional Items

Chapter

4

Connector Pinouts

4.1 Peripheral Interface Connectors

Section 4.1.2 shows peripheral interface connector locations. Section 4.1.2 lists all the peripheral interface connectors seen in Section 4.1.2.

4.1.1 IDDUPS-6364120 Layout

Figure 4-1 shows the on-board peripheral connectors, rear panel peripheral connectors and on-board jumper of IDDUPS-6364120.

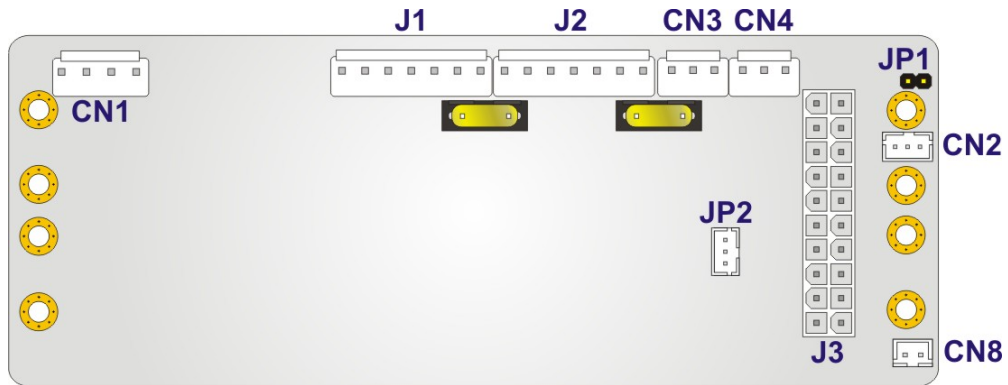

Figure 4-1: IDDUPS-6364120 Connector and Jumper Locations

4.1.2 IDDUPS-636260 Layout

Figure 4-1 shows the on-board peripheral connectors, rear panel peripheral connectors and on-board jumper of IDDUPS-636260.

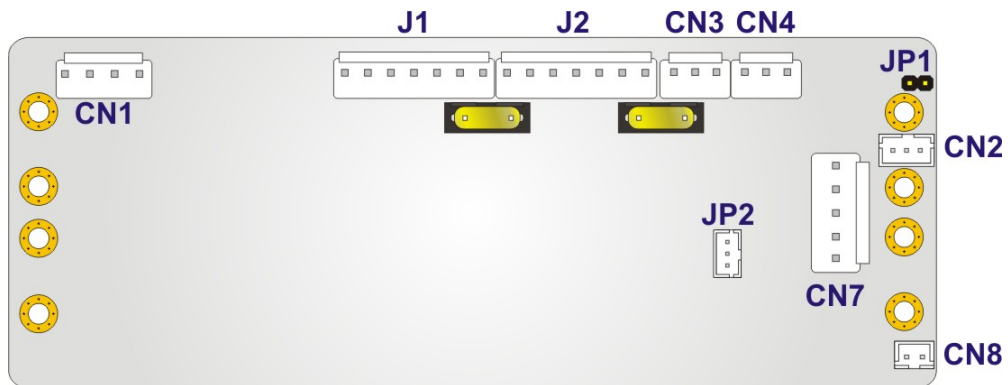

Figure 4-2: IDDUPS-636260 Connector and Jumper Locations

IDDUPS Series DC/DC Converter Module

4.1.3 Peripheral Interface Connectors

Table 4-1 shows a list of the peripheral interface connectors on the IDDUPS-6364120/636260. Detailed descriptions of these connectors can be found below.

| Connector | Type | Label |
|---|-----------------------|----------|
| ATX mode connector | 3-pin wafer connector | CN2 |
| ATX power connector (IDDUPS-6364120A only) | 20-pin connector | J3 |
| Battery connector | 7-pin wafer connector | J1, J2 |
| Input power connector | 4-pin wafer connector | CN1 |
| Output power connector | 3-pin wafer connector | CN3, CN4 |
| Power switch connector | 2-pin wafer connector | CN8 |
| RS-232 cable connector | 3-pin wafer connector | JP2 |
| SBC main power connector (IDDUPS-636260A only) | 5-pin wafer connector | CN7 |

Table 4-1: Peripheral Interface Connectors

4.1.4 Jumper

Table 4-2 lists the jumper on the IDDUPS-6364120/636260. Detailed descriptions of these jumper can be found in **Section 4.3**.

| Connector | Type | Label |
|---------------------------|--------------|-------|
| AT/ATX mode select jumper | 2-pin header | JP1 |

Table 4-2: Rear Panel Connectors

4.2 Internal Peripheral Connectors

Internal peripheral connectors are found on the motherboard and are only accessible when the motherboard is outside of the chassis. This section has complete descriptions of all the internal, peripheral connectors on the IDDUPS-6364120/636260.

4.2.1 ATX Mode Connector

- CN Label:** CN2
- CN Type:** 3-pin wafer connector (1x3)
- CN Location:** See **Figure 4-3**
- CN Pinout s:** See **Table 4-3**

Connect the ATX Mode Connector (CN2) to the motherboard to use ATX mode to control power on/off. The JP1 jumper should be open when using ATX mode (**Section 4.3.1**).

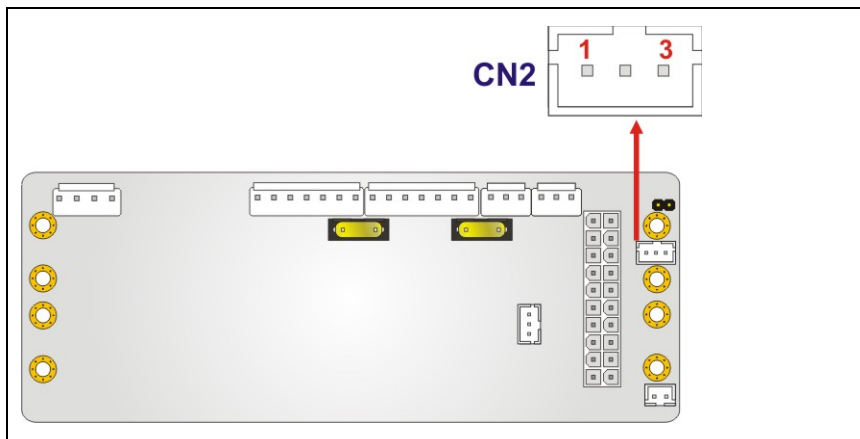

Figure 4-3: ATX Mode Connector Location

| PIN NO. | DESCRIPTION |
|---------|-------------|
| 1 | 5VSB |
| 2 | GROUND |
| 3 | PS_ON |

Table 4-3: ATX Mode Connector Pinouts

Use either one of the following cables to connect CN2 with motherboard:

IDDUPS Series DC/DC Converter Module



| | |
|---|--|
|  | Cable with on/off switch (P/N: CB-JST3PSW-RS) |
|  | Cable to SBC (5VSB & PS_ON) (P/N: CB-JST3P001-RS) |

Table 4-4: CN2 Connector Cables

4.2.2 ATX Power Connector (IDDUPS-6364120A Only)

- CN Label:** J3
- CN Type:** 20-pin connector (2x10)
- CN Location:** See Figure 4-4
- CN Pinouts:** See Table 4-5

The 20-pin ATX power connector is connected to an ATX power connector on the motherboard to provide output power.

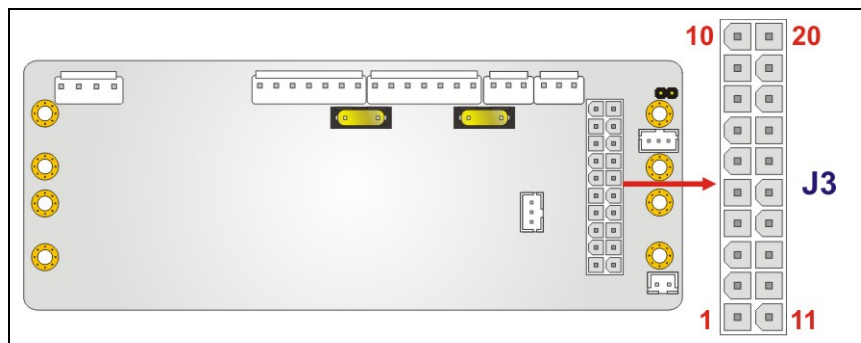

Figure 4-4: ATX Power Connector Location

| PIN NO. | DESCRIPTION | PIN NO. | DESCRIPTION |
|---------|-------------|---------|-------------|
| 1 | 3.3V | 11 | 3.3V |
| 2 | 3.3V | 12 | -12V |
| 3 | GND | 13 | GND |
| 4 | +5V | 14 | PS_ON |

| PIN NO. | DESCRIPTION | PIN NO. | DESCRIPTION |
|---------|-------------|---------|-------------|
| 5 | GND | 15 | GND |
| 6 | +5V | 16 | GND |
| 7 | GND | 17 | GND |
| 8 | Power good | 18 | -5V |
| 9 | 5VSB | 19 | +5V |
| 10 | +12V | 20 | +5V |

Table 4-5: ATX Power Connector Pinouts

Use the following cable to connect J3 with motherboard:

| | |
|---|---|
|  | 20p-20p ATX cable (for IDDUPS-6364120A) (P/N: CB-ATX20P-RS) |
|---|---|

Table 4-6: J3 Connector Cables

4.2.3 Battery Connectors

- CN Label:** J1, J2
- CN Type:** 7-pin wafer connector (1x7)
- CN Location:** See **Figure 4-5**
- CN Pinouts:** See **Table 4-7**

This connector is connected to the smart battery.

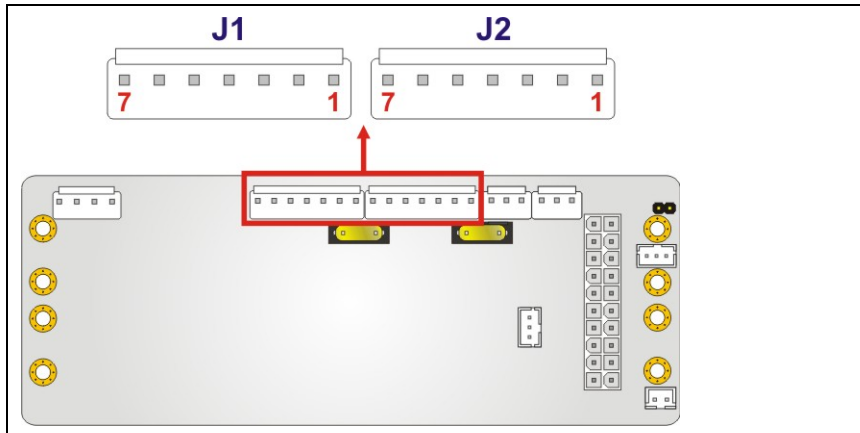

IDDUPS Series DC/DC Converter Module

Figure 4-5: Battery Connector Locations

| PIN NO. | DESCRIPTION |
|---------|-------------|
| 1 | BAT + |
| 2 | BAT + |
| 3 | Clock |
| 4 | DATA |
| 5 | Temp |
| 6 | GROUND |
| 7 | GROUND |

Table 4-7: Battery Connector Pinouts

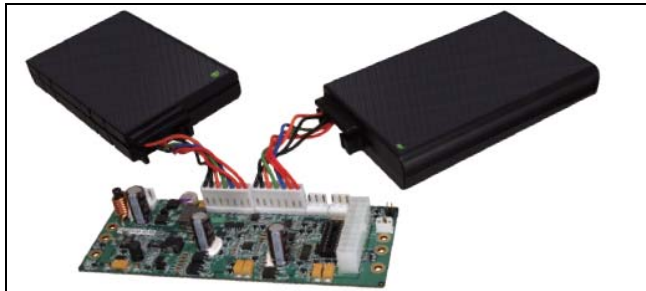

Figure 4-6: Battery Connected

4.2.4 Input Power Connector

- CN Label:** CN1
- CN Type:** 4-pin wafer connector (1x4)
- CN Location:** See **Figure 4-7**
- CN Pinouts:** See **Table 4-8**

The input power connector is connected to power source, such as a power adapter or a terminal block.

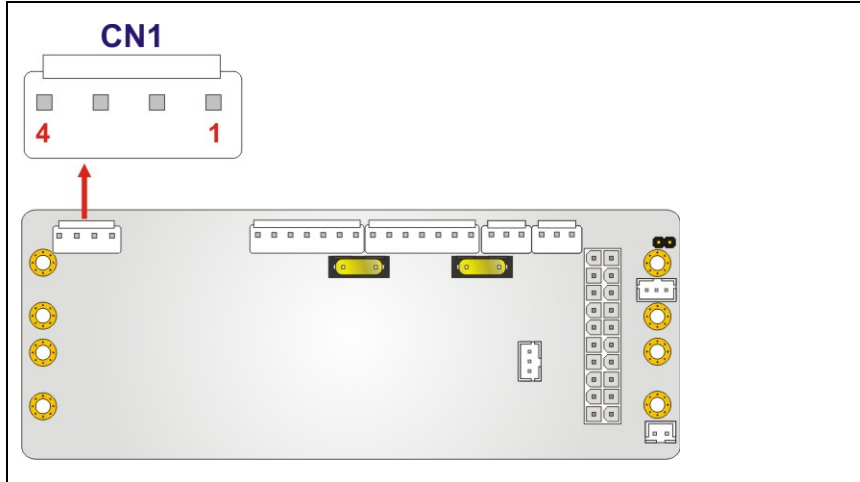



Figure 4-7: Input Power Connector Location

| PIN NO. | DESCRIPTION |
|---------|-------------|
| 1 | VIN |
| 2 | VIN |
| 3 | GROUND |
| 4 | GROUND |

Table 4-8: Input Power Connector Pinouts

Use either one of the following cables to connect CN1 with power source:

| | |
|---|---|
|  | <p>Cable for following AC-DC adapters</p> <ul style="list-style-type: none"> -FSP0601AD101C 60W -UP0451E12P 45W -UP0251E12PL 25W <p>(P/N: CB-P1LP4-RS)</p> |
|  | <p>Cable for 63000-FSP120AAB-RS 120W AC-DC adapter</p> <p>(P/N: CB-MD4P4-RS)</p> |

IDDUPS Series DC/DC Converter Module

| | |
|---|--|
|  | Cable for Terminal Block (P/N: CB-NOLP4-RS) |
|---|--|

Table 4-9: CN1 Connector Cables

4.2.5 Output Power Connectors

- CN Label:** CN3, CN4
- CN Type:** 3-pin wafer connector (1x3)
- CN Location:** See Figure 4-8
- CN Pinouts:** See Table 4-10

The power module provides power to devices through this output power connector.

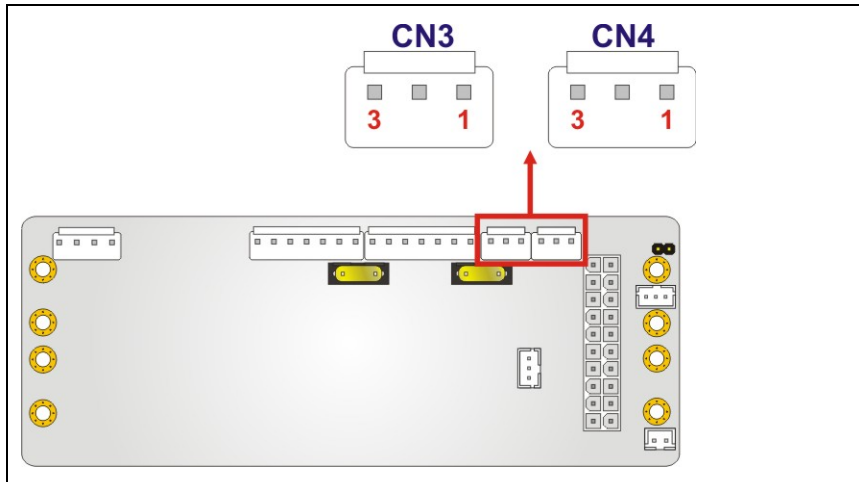

Figure 4-8: Output Power Connector Locations

| PIN NO. | DESCRIPTION |
|---------|-------------|
| 1 | +5V |
| 2 | GROUND |
| 3 | +12V |

Table 4-10: Output Power Connector Pinouts

Use either one of the following cables to connect CN3 or CN4 with HDD:



| | |
|---|--|
|  | Output power cable for SATA (P/N: CB-3PSATA-RS) |
|  | Output power cable for IDE or any standard 4-pin I/O devices (P/N: CB-3PIDE-RS) |

Table 4-11: CN3 & CN4 Connector Cables

4.2.6 Power Switch Connector

- CN Label:** CN8
- CN Type:** 2-pin wafer connector (1x2)
- CN Location:** See Figure 4-9
- CN Pinouts:** See Table 4-12

This connector connects to a power switch to activate or inactivate the power module. To prevent the connected Li-Polymer smart batteries from losing power, please inactivate the power module while not in use. To keep the power module always being able to be activated, please short pin 1 and pin 2 of the power switch connector (CN8).

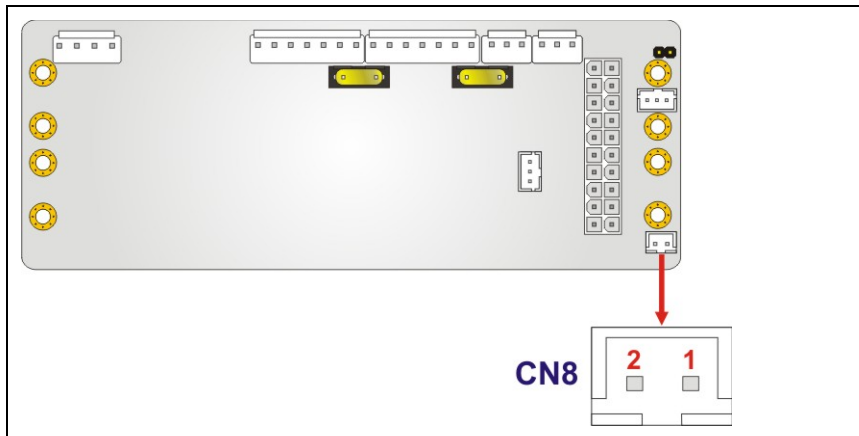

Figure 4-9: Power Switch Connector Locations

IDDUPS Series DC/DC Converter Module

| PIN NO. | DESCRIPTION |
|---------|-------------|
| 1 | BAT_SW |
| 2 | GROUND |

Table 4-12: Power Switch Connector Pinouts

4.2.7 RS-232 Cable Connector

- CN Label:** JP2
- CN Type:** 3-pin wafer connector (1x3)
- CN Location:** See **Figure 4-10**
- CN Pinouts:** See **Table 4-13**

This connector enables the IDDUPS series to communicate with the SBC through RS-232 serial port.

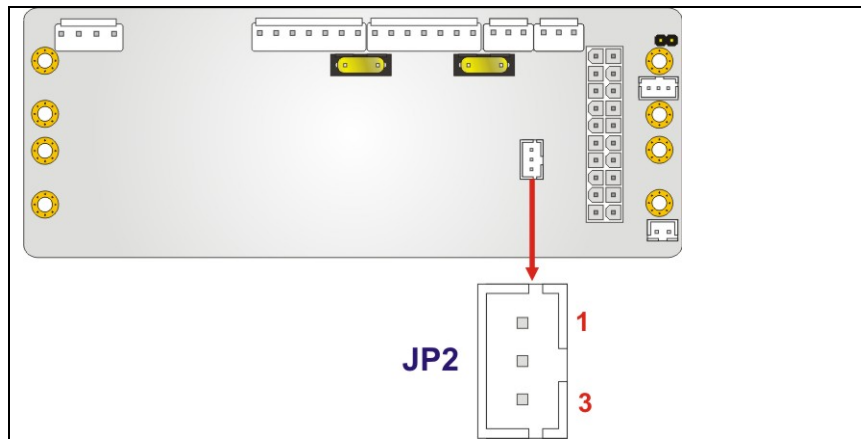

Figure 4-10: RS-232 Cable Connector Location

| PIN NO. | DESCRIPTION |
|---------|-------------|
| 1 | GROUND |
| 2 | TX |
| 3 | RX |

Table 4-13: RS-232 Cable Connector Pinouts

Use the following cable to connect JP2 with the serial port of the SBC.

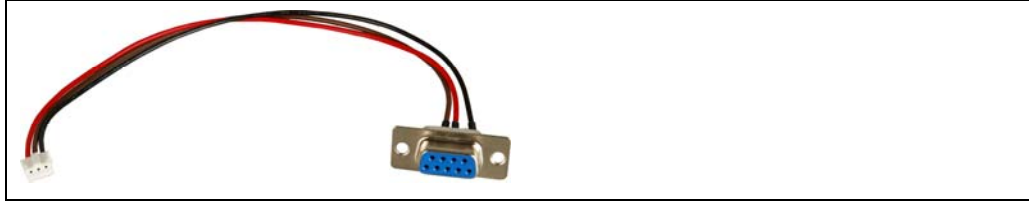

Figure 4-11: JP2 Connector Cable (RS-232 cable)

4.2.8 SBC Main Power Connector (IDDUPS-636260A Only)

- CN Label:** CN7
- CN Type:** 5-pin wafer connector (1x5)
- CN Location:** See **Figure 4-12**
- CN Pinouts:** See **Table 4-14**

This connector provides the main power to the single board computer (SBC).

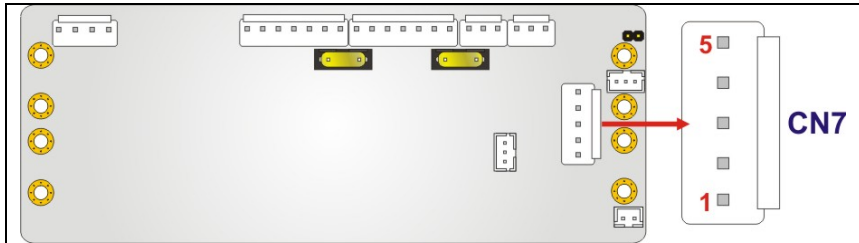

Figure 4-12: SBC Main Power Connector Location

| PIN NO. | DESCRIPTION |
|---------|-------------|
| 1 | +5V |
| 2 | +5V |
| 3 | GROUND |
| 4 | GROUND |
| 5 | +12V |

Table 4-14: SBC Main Power Connector Pinouts

Use the following cable to connect CN7 with SBC and SATA HDD:

IDDUPS Series DC/DC Converter Module

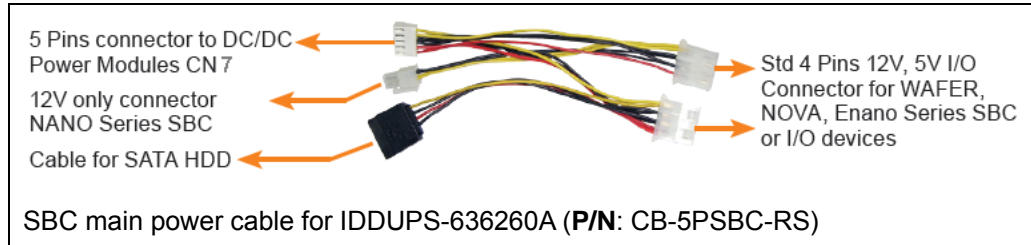

Figure 4-13: CN7 Connector Cables

4.3 Jumper Settings



NOTE:

A jumper is a metal bridge used to close an electrical circuit. It consists of two or three metal pins and a small metal clip (often protected by a plastic cover) that slides over the pins to connect them. To CLOSE/SHORT a jumper means connecting the pins of the jumper with the plastic clip and to OPEN a jumper means removing the plastic clip from a jumper.

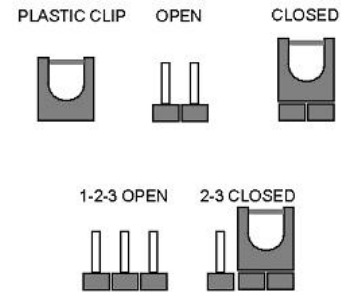

Jumper

Before the IDDUPS-6364120/636260 is installed in the system, the jumper must be set in accordance with the desired configuration. The jumper on the IDDUPS-6364120/636260 is listed below.

4.3.1 AT/ATX Mode Select Jumper

- CN Label:** **JP1**
- CN Type:** 2-pin header (1x2)
- CN Location:** See **Figure 4-14**
- CN Pinouts:** See **Table 4-15**

The AT/ATX mode select jumper allows the user to select AT or ATX power for the motherboard. If the ATX mode is selected, please connect CN2 (**Section 4.2.1**) to the motherboard to enable ATX power.

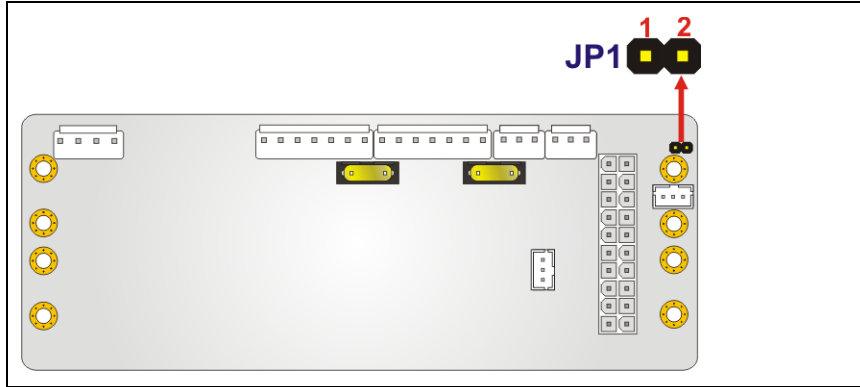

Figure 4-14: AT/ATX Mode Select Jumper Location

| JP1 | DESCRIPTION |
|-------|-------------|
| Short | AT |
| Open | ATX |

Table 4-15: AT/ATX Mode Select Jumper Settings

Chapter

5

Software Application

5.1 Introduction

The IEI IDDUPS Battery Status Monitor application detects the information of the smart battery and monitors the battery status. It is recommended to execute this IDDUPS application in Windows XP SP2 environment.

5.2 Monitoring DC Power and Smart Battery

5.2.1 Using the Application

Follow the steps below to start the IDDUPS Battery application.

Step 1: Use the RS-232 cable to connect the JP2 connector on the IDDUPS series to the serial port of the SBC. Please refer to **Section 4.3.1** for the location of the JP2 connector.

Step 2: Insert the application CD that comes with IDDUPS series.

Step 3: Double click the **IDDUPS.exe** icon (**Figure 5-1**).



Figure 5-1: IDDUPS Battery Status Monitor Application

5.2.2 Status Information

The IEI IDDUPS Battery Status Monitor application shows the DC power status and battery status (**Figure 5-2**). The following sections describe the status information in details.

IDDUPS Series DC/DC Converter Module

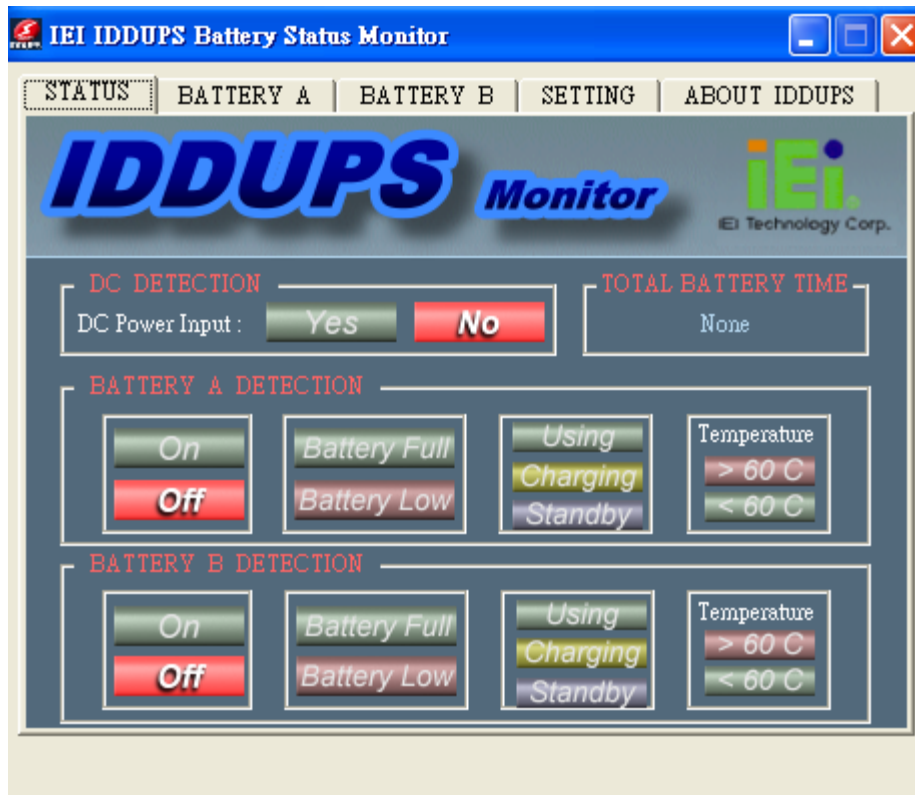

Figure 5-2: Status Information

5.2.2.1 DC Detection

When the DC power is connected to the IDDUPS series power module, the IDDUPS Battery Status Monitor detects it and shows in the screen as **Figure 5-3**.

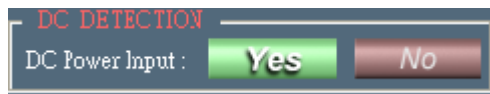

Figure 5-3: DC Detection

5.2.2.2 Battery Detection

When the smart battery is connected to the IDDUPS series power module, the IDDUPS Battery Status Monitor detects it and shows in the screen as **Figure 5-4**. Two batteries can be connected to the IDDUPS series power module at the same time. The second battery information is shown in the **Battery B Detection** section if connected.



Figure 5-4: Battery Detection

| | | |
|--|--------------|--|
| | On | The battery is connected to the IDDUPS series. |
| | Off | The battery is not connected to the IDDUPS series. |
| | Battery Full | The battery is fully charged. |
| | Battery Low | The battery is low. |
| | Using | The battery is being used. |
| | Charging | The battery is being charged. |
| | Standby | The battery is fully charged and ready to be used anytime. |
| | >60 C | The battery temperature is above 60°C. |
| | <60 C | The battery temperature is below 60°C. |

5.2.2.3 Battery Remaining Time

The battery remaining time is shown in the top right corner (**Figure 5-5**) of the status screen to indicate the total battery remaining time. To view the individual battery time, click on the BATTERY A/BATTERY B tab (**Section 5.2.3**).

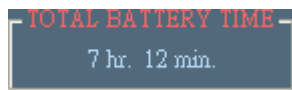

Figure 5-5: Battery Remaining Time

5.2.3 Battery Information

Click on the BATTERY A/ BATTERY B tab to view the information of battery A/ battery B. The listed information includes battery type, capacity, output voltage, temperature, charging rate, discharging rate and battery remaining time (Figure 5-6). The values listed are updated per second.

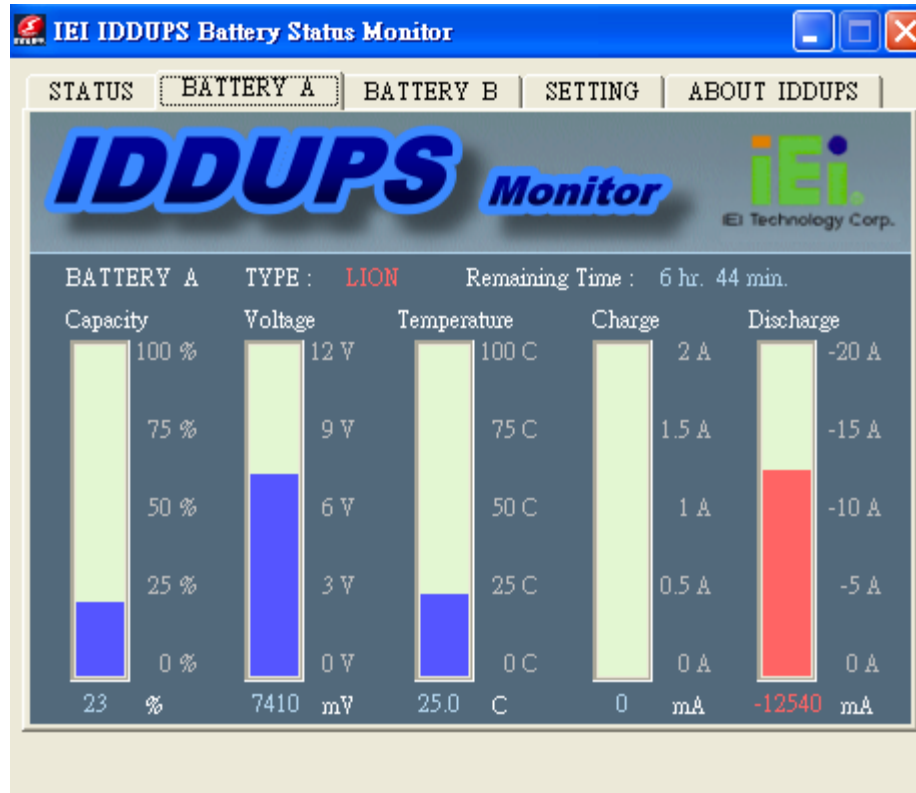

Figure 5-6: Battery Information

5.2.4 Setting

Click on the SETTING tab to select the COM port or enable/disable the special event pop-up window (Figure 5-7).

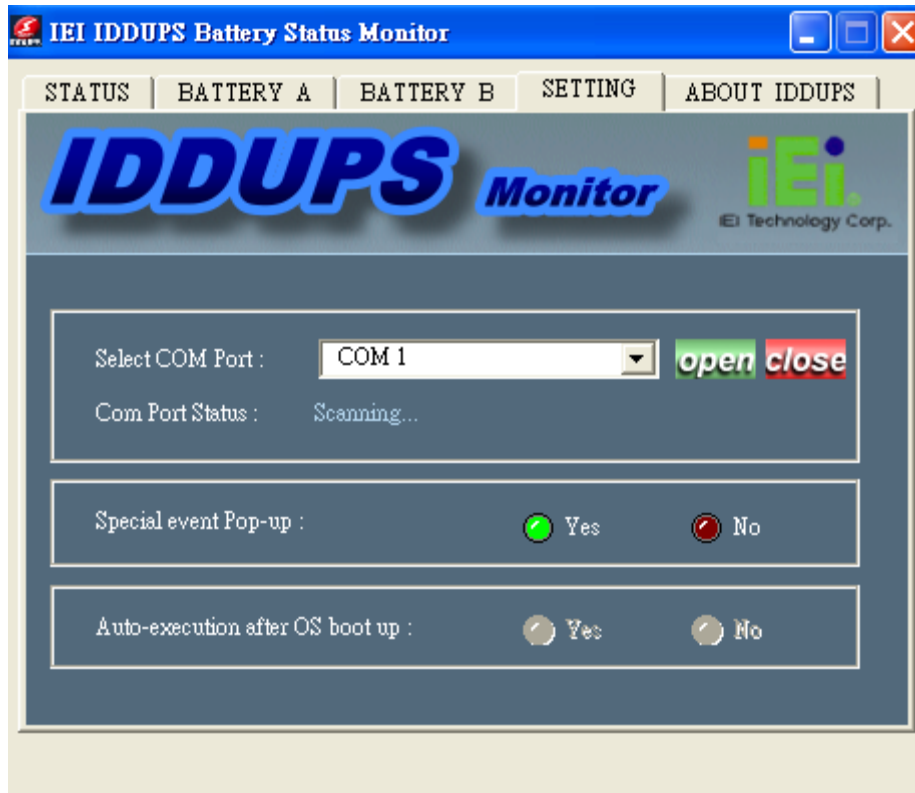

Figure 5-7: Application Setting

When the IDDUPS Battery Status Monitor application starts up, it automatically scans all COM port (COM1~COM16) and shows the valid COM port. **Figure 5-8** shows the IDDUPS application is communicating with IDDUPS module through COM 1.



Figure 5-8: COM Port Status

The IDDUPS Battery Status Monitor application will notify users with pop-up window if some special events happen, such as battery low or temperature over 60°C. This function can be enabled or disabled. Click **Yes** to enable or click **No** to disable (**Figure 5-9**).



Figure 5-9: Special Event Pop-up Setting

IDDUPS Series DC/DC Converter Module

5.3 System Log

The IDDUPS application provides easy access to the system log. To view the system log, right click the icon in the quick launch toolbar on the desktop as shown in **Figure 5-10** and select **System Log**.

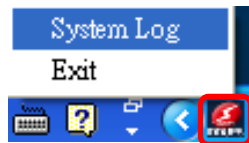

Figure 5-10: IDDUPS Application Quick Launch Icon

After clicking on the System Log, a screen pops-up (**Figure 5-11**) and displays all events that have happened.

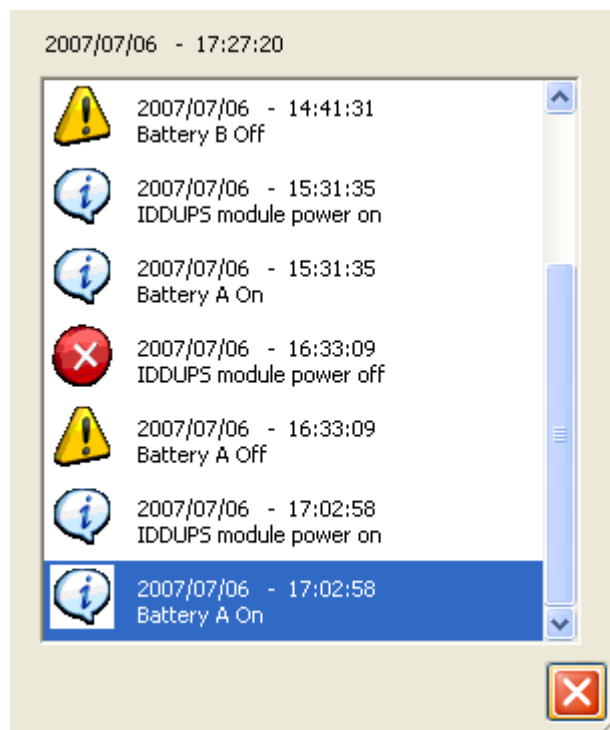

Figure 5-11: System Log Example

5.4 Exit

To close the IDDUPS application, right click the icon in the quick launch toolbar on the desktop as shown in and select **Exit** (Figure 5-12).

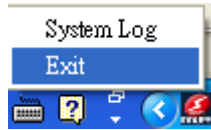

Figure 5-12: Exit IDDUPS Application

Appendix

A

Safety Precautions

**DANGER!****1. Disassemble and Reconstruction**

“Do not disassemble or reconstruct battery”

The battery pack has safety function and protection circuit to avoid the danger. If they have serious damage, it will cause the generating heat, smoke, rupture or flame.

2. Short-circuit

“Do not short-circuit battery”

Do not connect the + and – terminals with metals (such as wire). Do not carry or store the battery with metal objects (such as wire, necklace or hairpins). If the battery is short-circuited, excessive large current will flow and then the generating heat, smoke, rupture of flame will occur. And also, it causes generating heat at metals.

3. Incineration and Heating

“Do not incinerate or heat the battery”

These occur the melting of insulator, damage of gas release vent or safety function, or ignition on electrolyte. Above mentioned matters cause the generating heat, smoke, rupture or flame.

4. Use Nearby Heated Place

“Do not use or leave battery nearby the fire, stove or heated place (more than 80 °C)”

In case that separator made of polymer is melted by high temperature, the internal short-circuit occurs in individual cells and then it causes the generating heat, smoke, rupture or flame. In addition, do not use the battery under the heated place (more than 80 °C) for same reason.

5. Immersion

“Do not immerse the battery in water or sea water, or get it wet”

If the protection circuit included in the battery is broken, the battery will be charged at extreme current or voltage and the abnormal chemical reaction occurs in it. And then it causes the generating heat, smoke, rupture or flame.

6. Charge Nearby Heated Place

“Do not charge battery nearby the fire or under the blazing sun”

If the protection circuit to avoid the danger works under high temperature or it is broken, the battery will be charged at abnormal current (or voltage) and abnormal chemical reaction will occur. It caused the generating heat, smoke, rupture or flame.

7. Charger and Charge Condition

“Do use the specified charger and observe charging requirement”

If the battery is charged with unspecified condition (under high temperature over the regulated value, excessive high voltage or current over regulated value, or remodeled charger), there

IDDUPS Series DC/DC Converter Module

are cases that it will be overcharged or the abnormal chemical reaction will occur in cells. It caused the generating heat, smoke, rupture or flame.

8. Penetration

“Do not drive a nail into the battery, strike it by hammer, or tread it”

As the battery might be broken or deformed and then it will be short-circuited, it caused the generating heat, smoke, rupture or flame.

9. Impact

“Do not give battery impact or throw it”

The impact might cause leakage, heat, smoke, rupture, and/or fire of cell in the battery. And also if the protection circuit in the battery is broken, the battery will be charged at abnormal voltage or current, and abnormal chemical reaction might occur. It might cause leakage, heat, smoke rupture, and/or fire.

10. Deformation

“Do not use the battery with conspicuous damage or deformation”

It causes the generating heat, smoke, rupture or flame.

11. Soldering

“Do not make the direct soldering on battery”

As the insulator is melted by heat or the gas release vent (or safety function) is broken, it caused the generating heat, smoke, rupture or flame.

12. Reverse Charge and Overdischarge

“Do not reverse polarity (and terminals)”

On charging, the battery is reverse-charged and abnormal chemical reaction occurs. And also, there may be case that unexpected large current flows on discharging. These cause the generating heat, smoke, rupture or flame.

13. Reversed Polarity Use

“Do not reverse-charge or reverse-connect”

The battery has polarity. In case the battery is not connected with charger or equipment smoothly, do not force them to connect and do check polarity of battery. If the battery is connected to opposite polarity with charger, it will be reverse-charged and abnormal chemical reaction will occur. It causes the generating heat, smoke, rupture or flame.

14. Connect Battery to the Plug

“Do not connect battery to the plug socket or car-cigarette-plug”

Added high voltage to the battery, the excessive current will flow in it and then it will cause the generating heat, smoke, rupture or flame.

15. Inappropriate Use for Other Equipment

“Do not use battery for other equipment”

If the battery is used for unspecified equipment, it will deteriorate its performance and cycle-life.

At worst, abnormal current will flow or battery may generate heat, smoke, rupture or flame.

16. Leakage

“Do not touch a leaked battery directly”

in case the leaked electrolyte gets into eyes, wash them with fresh water as soon as possible without rubbing eyes. And then, see a doctor immediately.

If leave damaged eyes undone, it will cause eye-trouble.



WARNING:

1. Mixed Use

“Do not use Lithium ion battery in mixture”

Do not use Lithium ion battery with the primary batteries or secondary batteries whose capacity kind or maker is different, if do that, the battery will be discharged or charged excessively in use. And it may cause the generating, smoke, rupture or flaming because of the abnormal chemical reaction in cells.

2. Ingestion

“Keep the battery away from babies”

Keep the little battery out of the reach of babies in order to avoid troubles by swallowing. In case of swallowing the battery, see a doctor immediately.

3. Charging Time

“Do not continue to charge battery over specified time”

If the battery is not finished charging over regulated time, let it stop charging. There is possibility that the battery might generate, smoke, rupture or flame.

4. Store

“Do not get into a microwave or a high pressure container”

It causes the generating, smoke, rapture or flaming because of a sudden heat or damage of sealing condition of battery.

5. Leakage

“Do not use a leaked battery nearby fire”

If the liquid leaks from the battery (or the battery gives out bad smell), let the battery leave from flammable objects immediately. Unless do that, the electrolyte leaked from battery will catch fire and it will cause the smoke, flaming or rupture of it.

IDDUPS Series DC/DC Converter Module

6. Rust, Changing Color and Deformation

“Do not use an abnormal battery”

In case the battery has bad smell or is generated its changing color or deformation or causes something wrong in using (includes charging and storage), let it take out from equipment or charger and do not use it. If an abnormal battery is used, it will generate, smoke, rupture or flame.



CAUTION:

1. Use Under Strong Sunshine

Do not use or leave the battery under the blazing sun (or heated car by sunshine). The battery may generate heat, smoke or flame. And also, it might cause the deterioration of battery's characteristics or cycle life.

2. Static Electricity

The battery has the protection circuit to avoid the danger. Do not use nearby the place where generates static electricity (more than 100 V) which gives damage to the protection circuit. If protection circuit were broken, the battery would generate, smoke, rupture or flame.

3. Charging Temperature Range

Charging temperature range is regulated 0°C and 40°C. Do not charge the battery out of recommended temperature range. Charging out of recommended range might cause the generating heat or serious damage of battery. And also, it might cause the deterioration of battery's characteristics and cycle life.

4. Manual

Please read the manual before using the battery and keep it after reading.

5. Charging Method

Please read the manual of specified charger about charging method.

6. First Time Use

When the battery has rust, bad smell or something abnormal at first-time-using, do not use the equipment and bring the battery to the shop from which it was purchased.

7. Used By Children

In case younger children use the battery, their parents teach how to use batteries according to the manual with care. And also, when children are using the batteries, pay attention to use it according to that or not.

8. Keep Battery Away From Children

Keep the battery out of the reach of younger children. And also, pay attention when the battery is taken out from the charger or equipment by little children.

9. Leakage

If the skin or cloth is smeared with liquid from the battery, wash with fresh water. It may cause the skin inflammation.

Appendix

B

Hazardous Materials Disclosure

B.1 Hazardous Material Disclosure Table for IPB Products Certified as RoHS Compliant Under 2002/95/EC Without Mercury

The details provided in this appendix are to ensure that the product is compliant with the Peoples Republic of China (China) RoHS standards. The table below acknowledges the presences of small quantities of certain materials in the product, and is applicable to China RoHS only.

A label will be placed on each product to indicate the estimated “Environmentally Friendly Use Period” (EFUP). This is an estimate of the number of years that these substances would “not leak out or undergo abrupt change.” This product may contain replaceable sub-assemblies/components which have a shorter EFUP such as batteries and lamps. These components will be separately marked.

Please refer to the table on the next page.

IDDUPS Series DC/DC Converter Module

| Part Name | Toxic or Hazardous Substances and Elements | | | | | |
|---|--|--------------|--------------|------------------------------|--------------------------------|---------------------------------------|
| | Lead (Pb) | Mercury (Hg) | Cadmium (Cd) | Hexavalent Chromium (CR(VI)) | Polybrominated Biphenyls (PBB) | Polybrominated Diphenyl Ethers (PBDE) |
| Housing | O | O | O | O | O | O |
| Display | O | O | O | O | O | O |
| Printed Circuit Board | O | O | O | O | O | O |
| Metal Fasteners | O | O | O | O | O | O |
| Cable Assembly | O | O | O | O | O | O |
| Fan Assembly | O | O | O | O | O | O |
| Power Supply Assemblies | O | O | O | O | O | O |
| Battery | O | O | O | O | O | O |
| <p>O: This toxic or hazardous substance is contained in all of the homogeneous materials for the part is below the limit requirement in SJ/T11363-2006</p> <p>X: This toxic or hazardous substance is contained in at least one of the homogeneous materials for this part is above the limit requirement in SJ/T11363-2006</p> | | | | | | |

此附件旨在确保本产品符合中国 RoHS 标准。以下表格标示此产品中某有毒物质的含量符合中国 RoHS 标准规定的限量要求。

本产品上会附有“环境友好使用期限”的标签，此期限是估算这些物质“不会有泄漏或突变”的年限。本产品可能包含有较短的环境友好使用期限的可替换元件，像是电池或灯管，这些元件将会单独标示出来。

| 部件名称 | 有毒有害物质或元素 | | | | | |
|--------|-----------|-----------|-----------|-----------------|---------------|-----------------|
| | 铅 (Pb) | 汞 (Hg) | 镉 (Cd) | 六价铬 (CR(VI)) | 多溴联苯 (PBB) | 多溴二苯醚 (PBDE) |
| 壳体 | ○ | ○ | ○ | ○ | ○ | ○ |
| 显示 | ○ | ○ | ○ | ○ | ○ | ○ |
| 印刷电路板 | ○ | ○ | ○ | ○ | ○ | ○ |
| 金属螺帽 | ○ | ○ | ○ | ○ | ○ | ○ |
| 电缆组装 | ○ | ○ | ○ | ○ | ○ | ○ |
| 风扇组装 | ○ | ○ | ○ | ○ | ○ | ○ |
| 电力供应组装 | ○ | ○ | ○ | ○ | ○ | ○ |
| 电池 | ○ | ○ | ○ | ○ | ○ | ○ |

○: 表示该有毒有害物质在该部件所有物质材料中的含量均在 SJ/T11363-2006 标准规定的限量要求以下。
 X: 表示该有毒有害物质至少在该部件的某一均质材料中的含量超出 SJ/T11363-2006 标准规定的限量要求。