

Features

- 2-channel Counter/Frequency Input
- 32-bit Counter
- Isolated or Non-isolated Input
- Programmable Alarm Output
- Programmable Digital Filter
- Programmable Threshold Voltage Level
- Maximum Frequency of up to 100 kHz
- Built-in Virtual Battery Backup to Preserve Counter Values (I-7080B(D), M-7080B(D))
- Dual Watchdog
- Wide Operating Temperature Range: -25 ~ +75°C



Introduction

The I-7080 offers 2 high speed counter or frequency input channels and 2 digital output channels. Two types of digital input are provided, one for isolated input, and the other is for non-isolated input. The isolated input provides 3750 V_{rms} isolation voltage and the non-isolated input provides programmable threshold voltage level. The built-in digital filter is valid for both non-isolated and isolated input and can filter out noise where the high/low pulse width is smaller than the minimum high/low width of the digital filter. The maximum count is up to 32-bit and the maximum frequency is up to 100 kHz. The module also provides programmable alarm output with non-isolated open collectors. The M-7080 supports both the Modbus RTU and DCON protocols, which can be configured via software, and all hardware specifications are the same as the I-7080. The functions of the I-7080B are the same as that of the I-7080, except that the I-7080B provides a virtual battery backup function in counter mode.

System Specifications

Model	I-7080	I-7080B	M-7080	M-7080B
	I-7080D	I-7080BD	M-7080D	M-7080BD
Communication				
Interface	RS-485			
Format	(N, 8, 1) (N, 8, 2) (E, 8, 1) (O, 8, 1)			
Baud Rate	1200 ~ 115200 bps			
Protocol	DCON		Modbus RTU, DCON	
Dual Watchdog	Yes, Module (1.6 Seconds), Communication (Programmable)			
LED Indicators/Display				
System LED Indicator	Yes, 1 LED as Power/Communication Indicator			
I/O LED Indicators	-			
7-Segment LED Display	-			
	Yes			
Isolation				
Intra-module Isolation, Field-to-Logic	3000 Vdc			
EMS Protection				
ESD (IEC 61000-4-2)	±4 kV Contact for each Terminal			
EFT (IEC 61000-4-4)	±4 kV for Power Line			
Surge (IEC 61000-4-5)	±0.5 kV for Power Line			
Power				
Reverse Polarity Protection	Yes			
Input Range	10 ~ 30 Vdc	24 ~ 30 Vdc	10 ~ 30 Vdc	24 ~ 30 Vdc
Consumption	2.0 W			
	2.2 W			
Mechanical				
Dimensions (W x L x H)	72 mm x 123 mm x 35 mm			
Installation	DIN-Rail or Wall Mounting			
Environment				
Operating Temperature	-25 ~ +75°C			
Storage Temperature	-40 ~ +85°C			
Humidity	10 ~ 95% RH, Non-condensing			

Applications

- Building Automation
- Machine Automation
- Remote Diagnosis
- Factory Automation
- Remote Maintenance
- Testing Equipment

I/O Specifications

Model	I-7080	I-7080B	M-7080	M-7080B
	I-7080D	I-7080BD	M-7080D	M-7080BD
Digital Input				
Channels	2			
Contact	Wet			
Sink/Source (NPN/PNP)	Sink			
On Voltage Level	Isolated	+3.5 ~ +30 Vdc		
	Non-isolated	+2.4 ~ +5 Vdc		
Off Voltage Level	+1 Vdc Max.			
Programmable Filter	2 μs to 65 ms			
Programmable Threshold Voltage	+0.1 ~ +5 Vdc			
Individual Channel Configuration	No			
Counter/Encoder-bits	32-bit			
Counter Mode	Up			
Encoder Mode	-			
Frequency Mode	Yes			
Virtual Battery Backup	-	Yes	-	Yes
Frequency Accuracy	1 Hz or 10 Hz			
Max. Speed	100 KHz			
Digital Output				
Channels	2			
Type	Open Collector			
Sink/Source (NPN/PNP)	Sink			
Load Voltage	+3.5 ~ +30 Vdc			
Max. Load Current	30 mA/Channel			

Internal I/O Structure

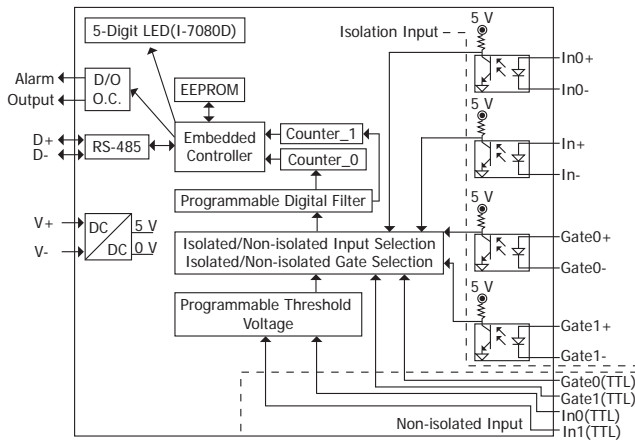

Pin Assignments

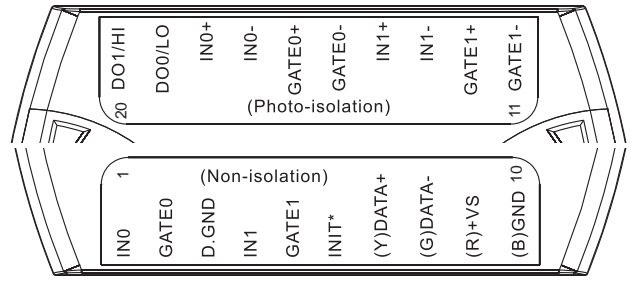

Wire Connections

Counter Type Wire Connection		
Isolation	Non-isolation	
Counter Input+ INx+ Counter Input- INx- Gate Control+ GATEx+ Gate Control- GATEx-	Counter Input INx Gate Control GATEx Ground D.GND	
Frequency Type Wire Connection		
Isolation	Non-isolation	
Frequency Input+ INx+ Frequency Input- INx- Not used GATEx+ Not used GATEx-	Frequency Input+ INx Not used GATEx Frequency Input- D.GND	
Output Type	ON State Readback as 1	OFF State Readback as 0
Resistance Load		
Inductance Load		

Ordering Information

I-7080 CR	2-channel Counter/Frequency Input Module with DCON Protocol (Blue Cover) (RoHS)
I-7080-G CR	2-channel Counter/Frequency Input Module with DCON Protocol (Gray Cover) (RoHS)
I-7080D CR	I-7080 with 7-segment LED Display (Blue Cover) (RoHS)
I-7080B-G CR	2-channel Counter/Frequency Input Module with DCON Protocol with Virtual Battery Backup (Gray Cover) (RoHS)
I-7080BD-G CR	I-7080B with 7-segment LED Display (Gray Cover) (RoHS)
M-7080-G CR	2-channel Counter/Frequency Input Module with DCON and Modbus Protocol (Gray Cover) (RoHS)
M-7080D-G CR	M-7080 with 7-segment LED Display (Gray Cover) (RoHS)
M-7080B-G CR	2-channel Counter/Frequency Input Module with DCON and Modbus Protocol with Virtual Battery Backup (Gray Cover) (RoHS)
M-7080BD-G-G CR	M-7080B with 7-segment LED Display (Gray Cover) (RoHS)

Accessories

	SG-770 CR	7-channel Differential or 14-channel Single-ended Surge Protector (RoHS)
--	-----------	--

2
3

RS-485 Remote I/O Modules

I-7080(D)/I-7080B(D)/M-7080(D)/M-7080B(D)